

TAS5010-5112F2EVM Application Report

Jonas Svendsen

Digital Audio and Video Products

The TAS5010-5112F2EVM PurePath Digital™ customer evaluation module demonstrates the integrated circuits TAS5010PFB and TAS5112ADFD from Texas Instruments.

The TAS5010PFB is a 24-bit input stereo PurePath Digital™ pulse width modulator (PWM) based on Equibit™ technology for sample rates up to 192 kHz.

The TAS5112ADFD is a high-performance digital amplifier power stage designed to drive two 6-Ω loudspeakers up to 65 W (10% THD+N) in bridge tied load (BTL) configuration. It contains integrated gate-drivers, eight matched and electrically isolated enhancement-mode N-channel power DMOS transistors, and protection/fault reporting circuitry.

The DFD package has a PowerPad™ on the top side for heat transfer to a heatsink. The heatsink delivered with this EVM is for evaluation purpose only.

This EVM is a complete stereo digital audio amplifier system which includes digital input (S/PDIF), analog input/output, interface to PC, volume control, and failure protection.

This system is designed for home audio applications such as television sets, home theater in a box (HTIB), DVD receivers, or plasma display panels (PDP).

This document covers EVM specifications, audio performance and power efficiency measurements graphs and design documentation that includes schematics, parts list, layout, and mechanical design.

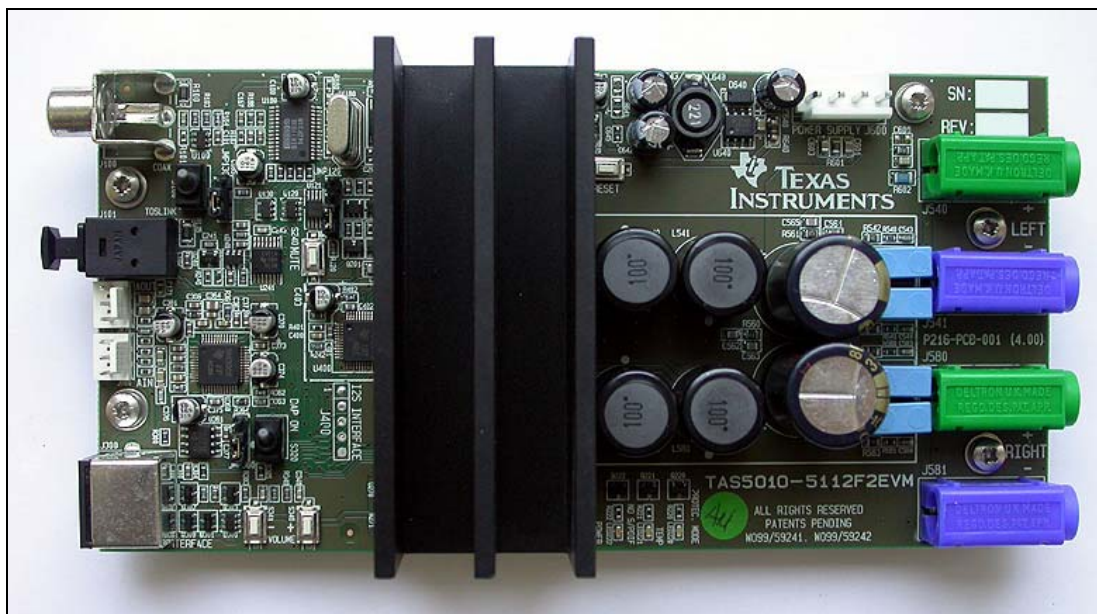

For EVM setup and use, see the TAS5010-5112F2EVM User's Guide (SLEU056).

For Gerber (layout) and parts list (MS Excel format) files, see the PurePath Digital™ CD-ROM or contact your local Texas Instruments representative for digital audio.

Contents

1	TAS5010-5112F2EVM Specification	3
1.1	THD+N vs Power	5
1.2	THD+N vs Frequency.....	6
1.3	FFT With -60-dB Input Signal.....	7
1.4	Noise Floor.....	8
1.5	Channel Separation vs Frequency.....	9
1.6	Frequency Response.....	10
1.7	Overcurrent Protection.....	11
1.8	Output Stage Efficiency.....	12
2	References.....	13
Appendix A. Design Documents.....		14

Figures

Figure 1.	THD+N vs Power	5
Figure 2.	THD+N vs Frequency.....	6
Figure 3.	FFT With -60-dB Input Signal.....	7
Figure 4.	Noise Floor.....	8
Figure 5.	Channel Separation vs Frequency.....	9
Figure 6.	Frequency Response.....	10
Figure 7.	Overcurrent Protection.....	11
Figure 8.	Output Stage Efficiency.....	12

Tables

Table 1.	General Test Conditions.....	3
Table 2.	Electrical Data.....	3
Table 3.	Audio Performance.....	3
Table 4.	Thermal Specifications.....	4
Table 5.	Physical Specifications.....	4

1 TAS5010-5112F2EVM Specification

Table 1. General Test Conditions

General Test Conditions	Typical Values	Notes
Output Stage Supply Voltage	29.5 V	Laboratory Power Supply (EA-PS 7065-10A)
System Supply Voltage	29.5 V	
Load Impedance	6 Ω	
Sampling Frequency	44.1 kHz	
PWM Processor	TAS5010	
Output Stage	TAS5112ADFD	
Digital Audio Processor	TAS3002	

Table 2. Electrical Data

Electrical Data	Typical Values	Notes/Conditions
Output Power 6 Ω	50 W/Channel	<0.2% THD+N, 1 kHz, $T_A = 25^\circ\text{C}$
Output Power 6 Ω , 10% THD	>65 W/Channel	10% THD+N, 1 kHz, $T_A = 25^\circ\text{C}$
Output Power 8 Ω	40 W/Channel	<0.09% THD+N, 1 kHz, $T_A = 25^\circ\text{C}$
Maximum Output Power Per Channel	50 W/Channel	2 ch at max power for 5 min, 1 kHz, preheated one hour at 1/3 max power. $T_A = 25^\circ\text{C}$ <0.15% THD+N, $P_{OUT} = 2 \times 50 \text{ W}$, 6 Ω , 1 kHz
Output Stage Efficiency	88%	
Total Board Idle Power Consumption	4.1 W	
Rated Load Impedance	6-8 Ω	
Damping Factor	15	1 kHz, relative to 8- Ω load
Maximum Peak Current	>8 A	1-kHz burst, 1 Ω
Total Supply Current	125 mA	

Table 3. Audio Performance

Audio Performance (S/PDIF input)	Typical Values	Notes/Conditions
THD+N, 1 W, 6 Ω	<0.03%	1 kHz
THD+N, 10 W, 6 Ω	<0.04%	1 kHz
THD+N, 50 W, 6 Ω	<0.2%	1 kHz
Dynamic Range	>95 dB	Ref: rated power, A-weighted, AES17 filter
Noise Voltage	<360 μV_{RMS}	A-weighted, AES17 filter
Channel Separation	62 dB	1 kHz, $P_{OUT} = 50 \text{ W}$
Amplitude Response DC – 20 kHz	$\pm 0.5 \text{ dB}$	50 W unclipped, 6 Ω
Audio Performance (Analog input)		
THD+N, 1 W, 6 Ω	<0.04%	1 kHz
THD+N, 10 W, 6 Ω	<0.05%	1 kHz
THD+N, 50 W, 6 Ω	<0.2%	1 kHz
Dynamic Range	>94 dB	Ref: rated power, A-weighted, AES17 filter
Noise Voltage	<400 μV_{RMS}	A-weighted, AES17 filter
Channel Separation	62 dB	1 kHz, $P_{OUT} = 50 \text{ W}$
Amplitude Response DC – 20 kHz	$\pm 0.5 \text{ dB}$	50 W unclipped, 6 Ω
Sensitivity	2.3 V_{RMS}	50 W unclipped
Input Impedance	10 k Ω	1 kHz
Audio Performance (Analog output)		
Maximum Output Voltage	0.7 V_{RMS}	
Output Impedance	75 Ω	1 kHz

Table 4. Thermal Specifications

Thermal specification	T_{HEATSINK}	Notes/Conditions
Idle, all ch switching	39°C	1 kHz, T _A = 25°C
1/3 power, 2 ch switching	45°C	1 kHz, 1 hour, T _A = 25°C
2 x 50 W (6 Ω)	65°C	1 kHz, 2 channels loaded, 5 min, T _A = 25°C

Note: Amplifier mounted with a prototype heat sink, free air.

Table 5. Physical Specifications

Physical Specifications		Notes/Conditions
PCB dimensions	150 mm x 80 mm	Length x Width
Heat sink	35 mm x 78 mm x 32 mm	Length x Width x Height
Total weight	240 g	Components + PCB + Mechanics

Note: All electrical and audio specifications are typical values.

1.1 THD+N vs Power

Left Channel

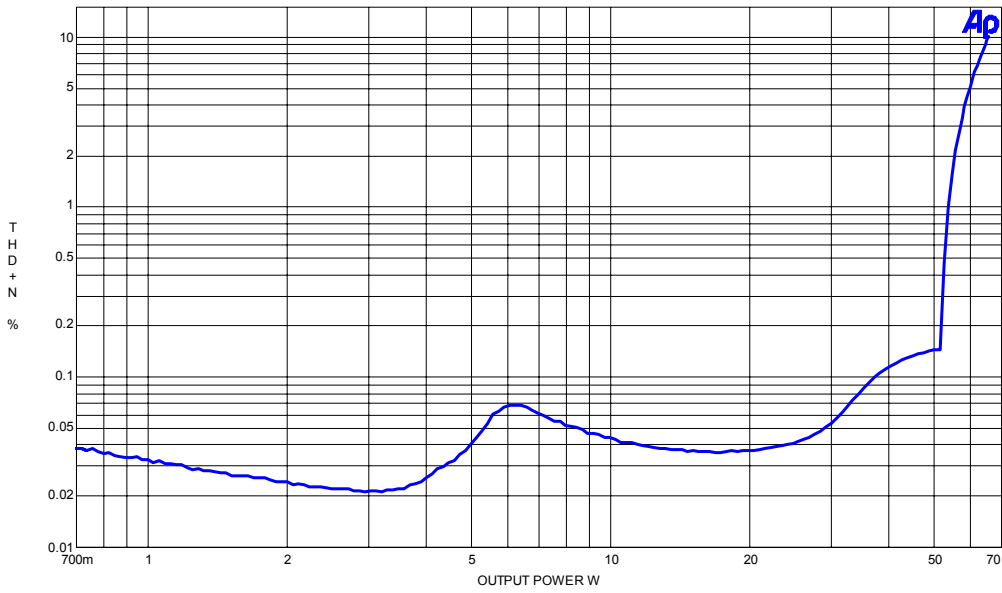

Comments: Power supply = 29.5 V Load = 6 Ω Filter: AES17
 Input signal = 1 kHz Sample frequency = 44.1 kHz DAP bypassed, S/PDIF coaxial input

Right Channel

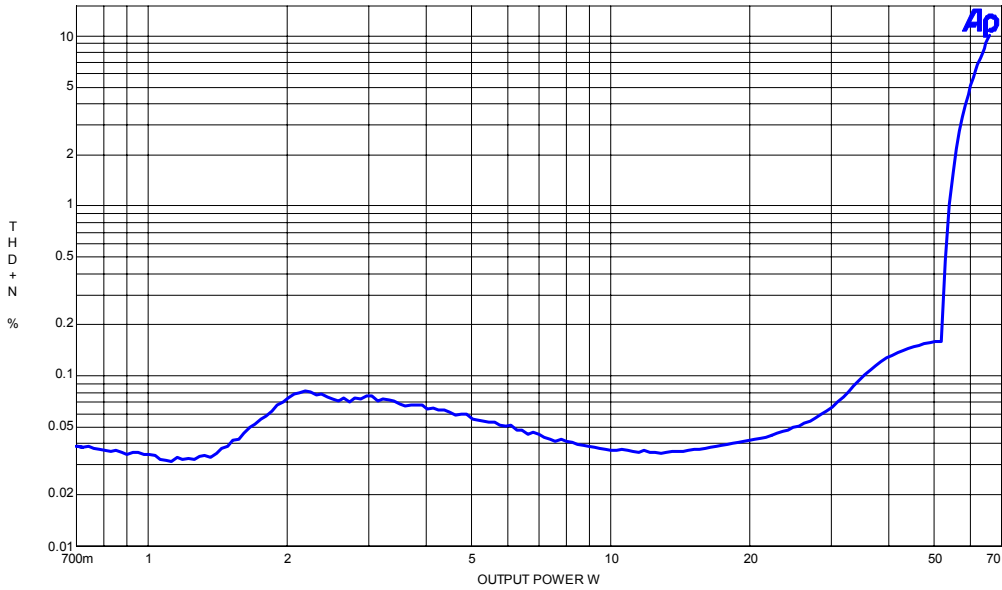

Comments: Power supply = 29.5 V Load = 6 Ω Filter: AES17
 Input signal = 1 kHz Sample frequency = 44.1 kHz DAP bypassed, S/PDIF coaxial input

Figure 1. THD+N vs Power

1.2 THD+N vs Frequency

Left Channel

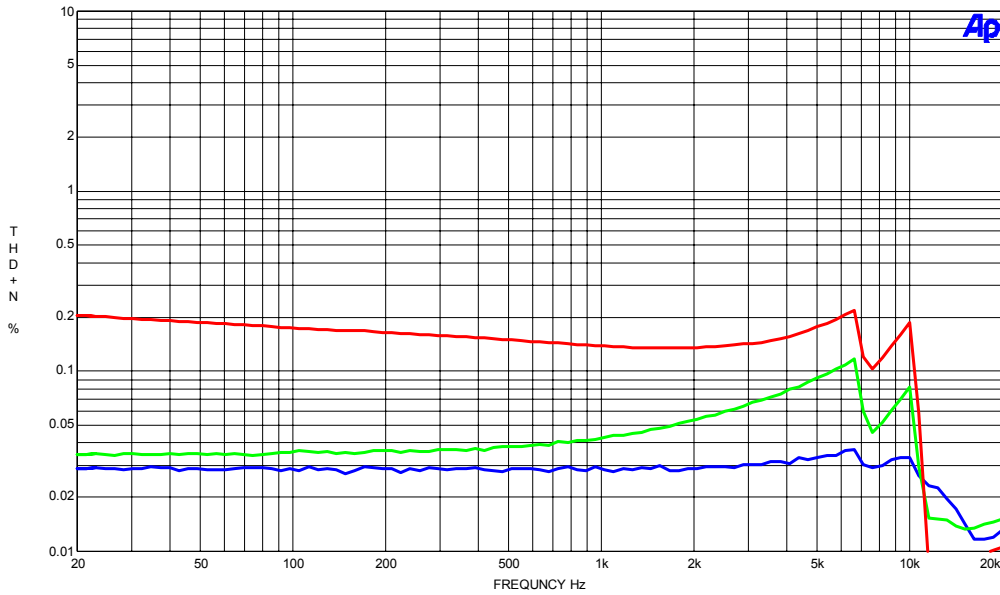

Comments: **Blue = 1 W** **Green = 10 W** **Red = 50 W** Sample frequency = 44.1 kHz
 Power supply = 29.5 V Load = 6 Ω Filter: AES17 DAP bypassed, S/PDIF coaxial input

Right Channel

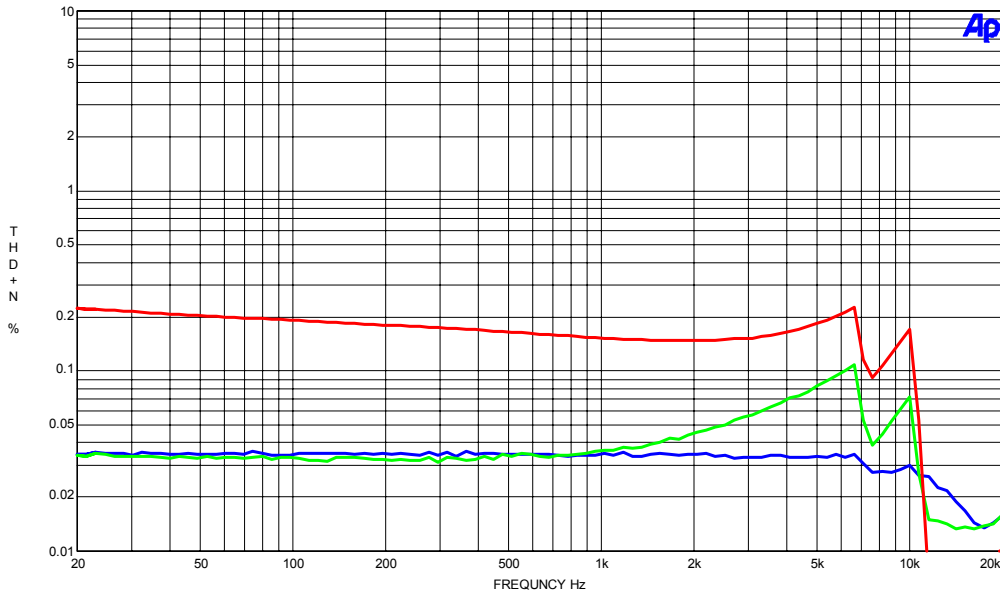

Comments: **Blue = 1 W** **Green = 10 W** **Red = 50 W** Sample frequency = 44.1 kHz
 Power supply = 29.5 V Load = 6 Ω Filter: AES17 DAP bypassed, S/PDIF coaxial input

Note: THD+N at high frequencies depends on the output-filter coil material.

Figure 2. THD+N vs Frequency

1.3 FFT With -60-dB Input Signal

Left Channel

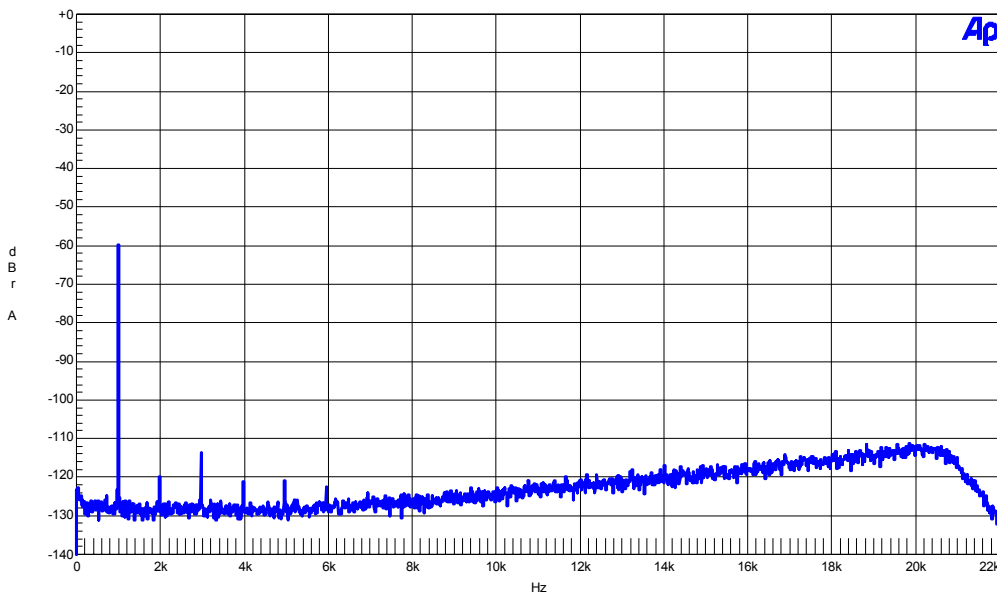

Comments: Power supply = 29.5 V Load = 6 Ω Filter: AES17 DAP bypassed, S/PDIF coaxial input
 Input signal = 1 kHz Sample frequency = 44.1 kHz FFT size: 16 k Reference: 17.6 V = full scale

Right Channel

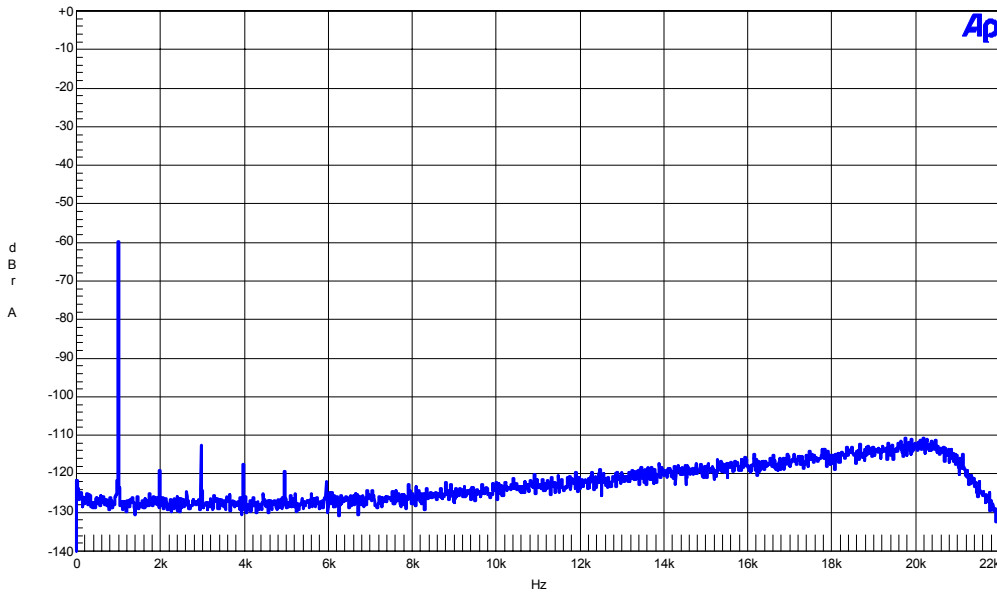

Comments: Power supply = 29.5 V Load = 6 Ω Filter: AES17 DAP bypassed, S/PDIF coaxial input
 Input signal = 1 kHz Sample frequency = 44.1 kHz FFT size: 16 k Reference: 17.6 V = full scale

Figure 3. FFT With -60-dB Input Signal

1.4 Noise Floor

Left Channel

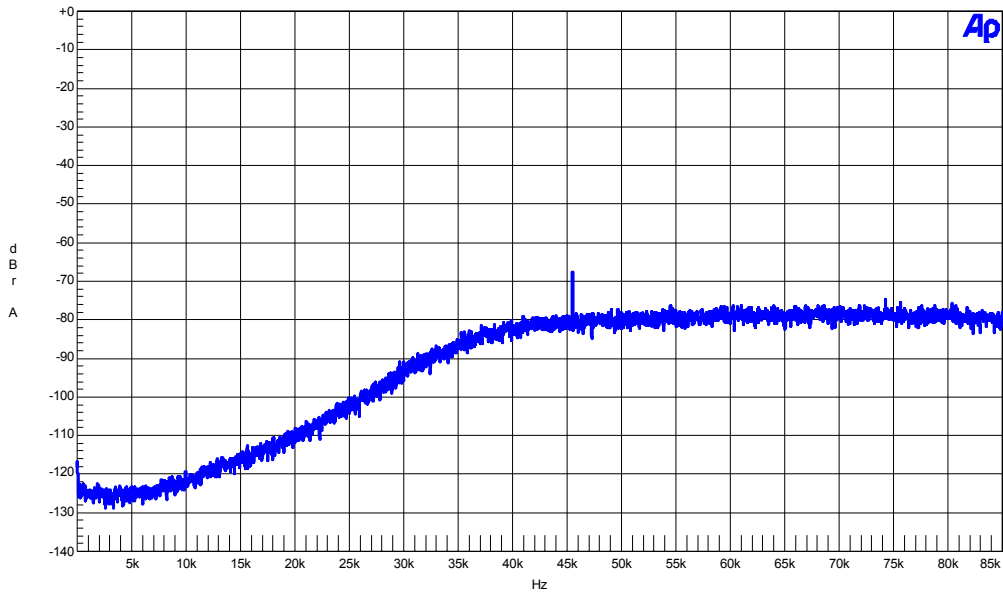

Comments: Power supply = 29.5 V Load = 6 Ω FFT size: 16 k Reference: 17.6 V = full scale
 Input signal = 0 Fs Sample frequency = 44.1 kHz DAP bypassed, S/PDIF coaxial input

Right Channel

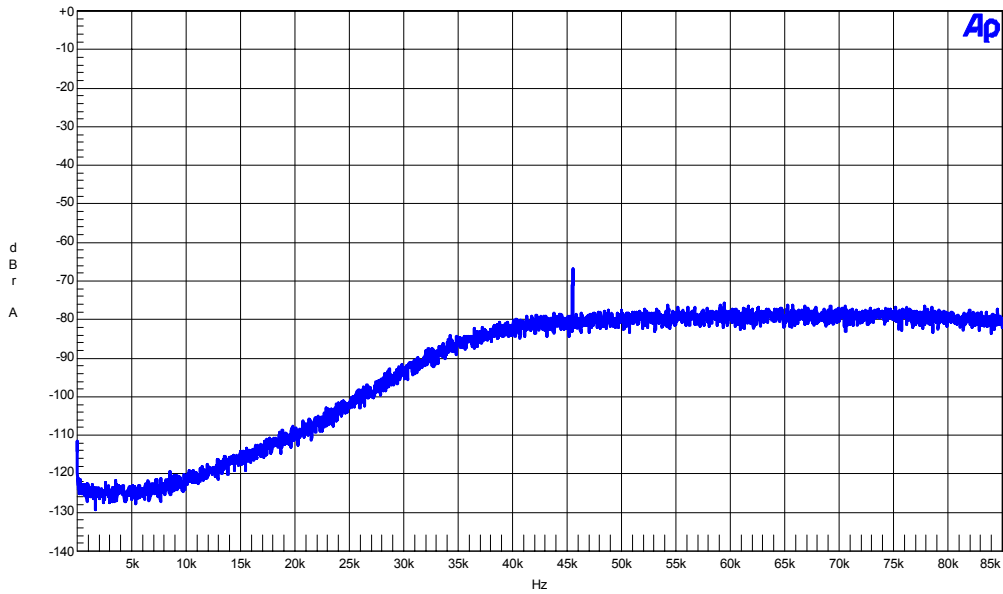

Comments: Power supply = 29.5 V Load = 6 Ω FFT size: 16 k Reference: 17.6 V = full scale
 Input signal = 0 Fs Sample frequency = 44.1 kHz DAP bypassed, S/PDIF coaxial input

Figure 4. Noise Floor

1.5 Channel Separation vs Frequency

Left Channel

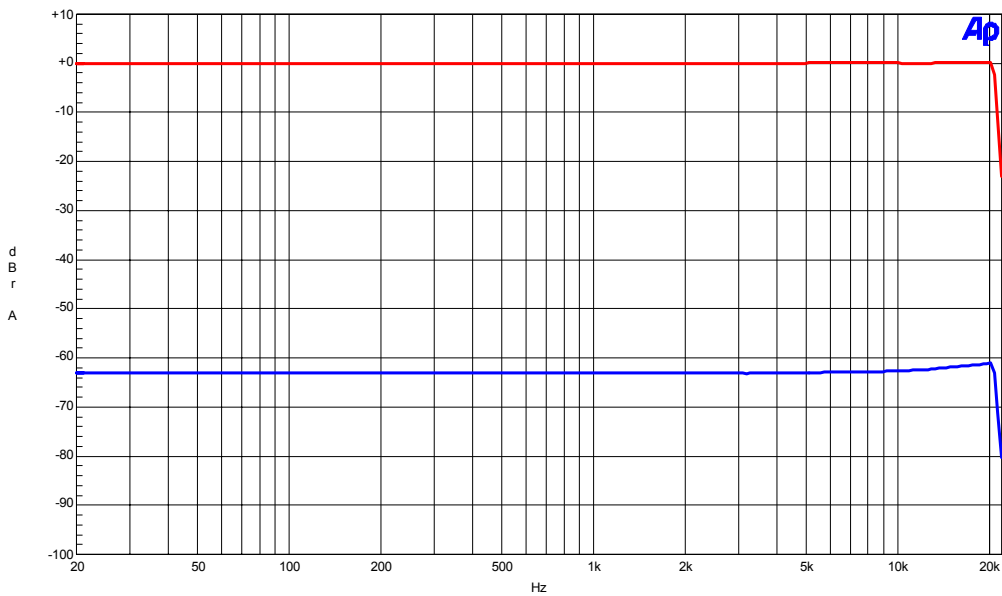

Comments: **Blue = Left output** **Red = Right output**
 Input left channel = 0 Fs Load = 6 Ω Sample frequency = 44.1 kHz DAP bypassed, S/PDIF coaxial input
 Input right channel = 1 Fs Filter: AES17 Power supply = 29.5 V

Right Channel

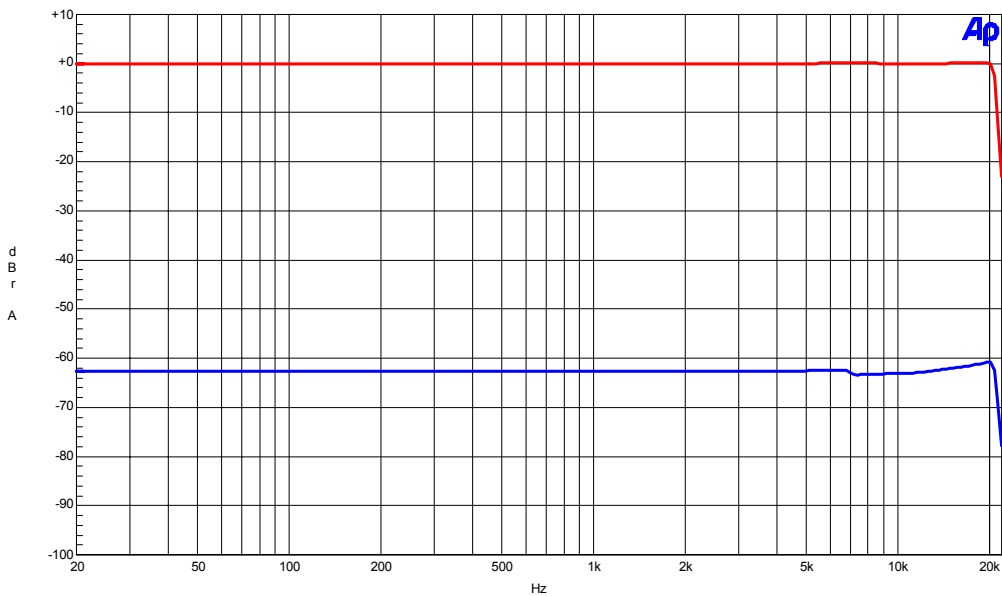

Comments: **Blue = Right output** **Red = Left output**
 Input left channel: 1 Fs Load = 6 Ω Sample frequency = 44.1 kHz DAP bypassed, S/PDIF coaxial input
 Input right channel: 0 Fs Filter: AES17 Power supply = 29.5 V

Figure 5. Channel Separation vs Frequency

1.6 Frequency Response

Left Channel

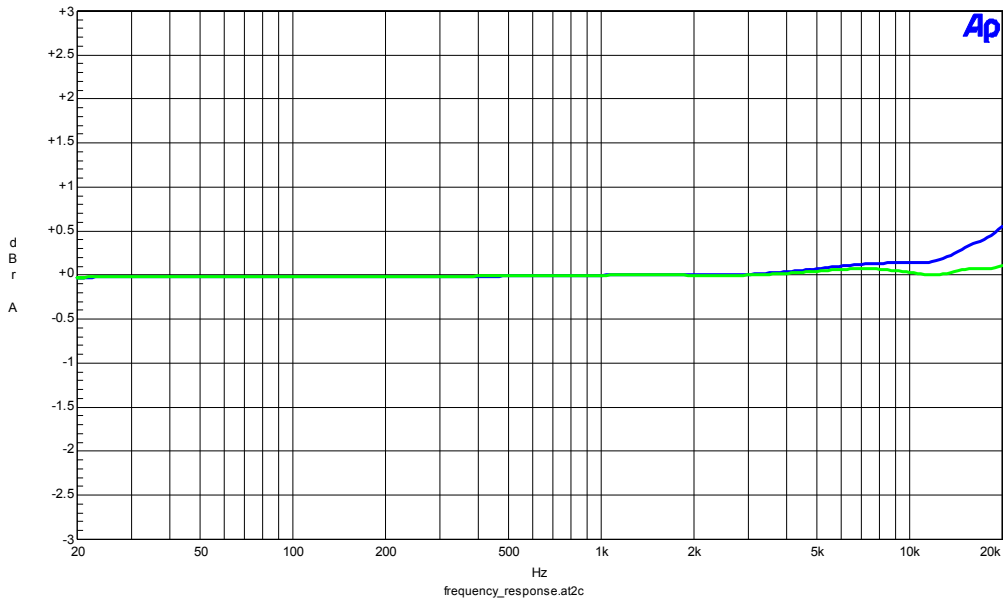

Comments: **Blue = 8 Ω** **Green = 6 Ω** DAP bypassed, S/PDIF coaxial input
 Input signal = 1 kHz Sample frequency = 44.1 kHz Power supply = 29.5 V

Right Channel

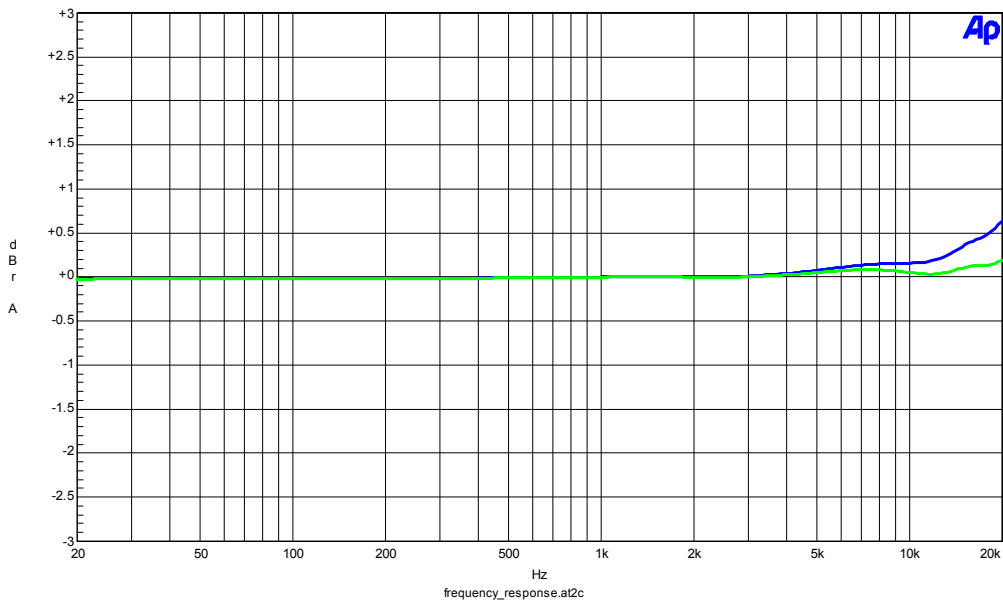

Comments: **Blue = 8 Ω** **Green = 6 Ω** DAP bypassed, S/PDIF coaxial input
 Input signal = 1 kHz Sample frequency = 44.1 kHz Power supply = 29.5 V

Figure 6. Frequency Response

1.7 Overcurrent Protection

Left Channel

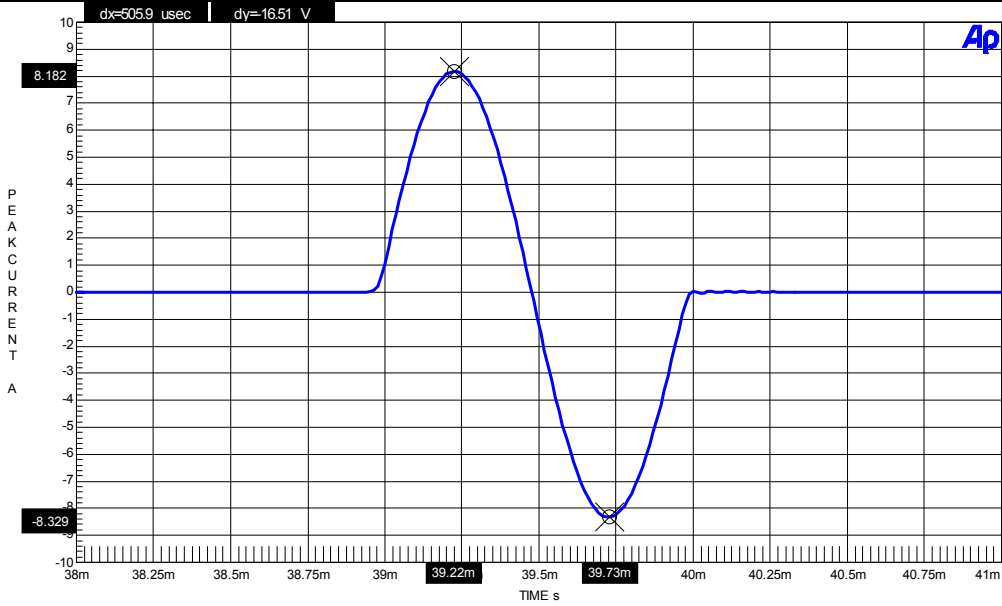

Comments: Input signal = 1 kHz Sample frequency = 44.1 kHz DAP bypassed, S/PDIF coaxial input
 Load = 1 Ω Power supply = 29.5 V

Figure 7. Overcurrent Protection

1.8 Output Stage Efficiency

Amplifier Efficiency vs Total Delivered Power

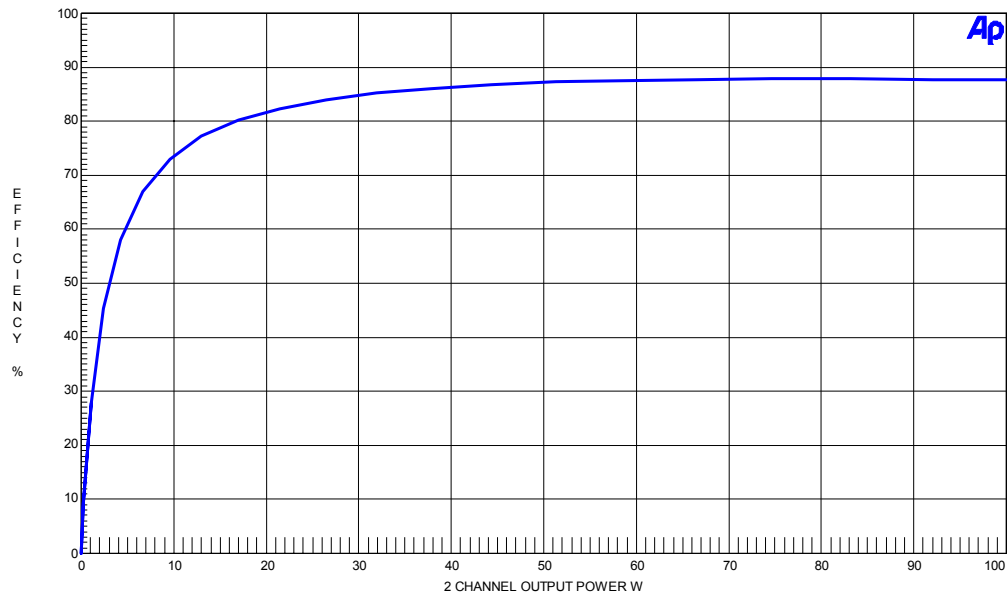

Comments: Input signal = 1 kHz Sample frequency = 44.1 kHz Loads = 6 Ω Power supply = 29.5 V

Figure 8. Output Stage Efficiency

2 References

1. *System Design Considerations for True Digital Audio Power Amplifiers* (SLAA117)
2. *Digital Audio Measurements* (SLAA114)
3. *Voltage Spike Measurement Technique and Specification* (SLEA025)

Appendix A. Design Documents

TAS5010-5112F2EVM Schematic	Version 5.00	7 pages
TAS5010-5112F2EVM Parts List	Version 5.00	2 pages
TAS5010-5112F2EVM PCB Specification	Version 4.00	1 page
TAS5010-5112F2EVM PCB Layers	Version 4.00	3 pages
TAS5010-5112F2EVM Mechanical Design	Version 1.00	2 pages
TAS5010-5112F2EVM ECO-003	Version 1.00	1 page

AUDIO INPUT SECTION

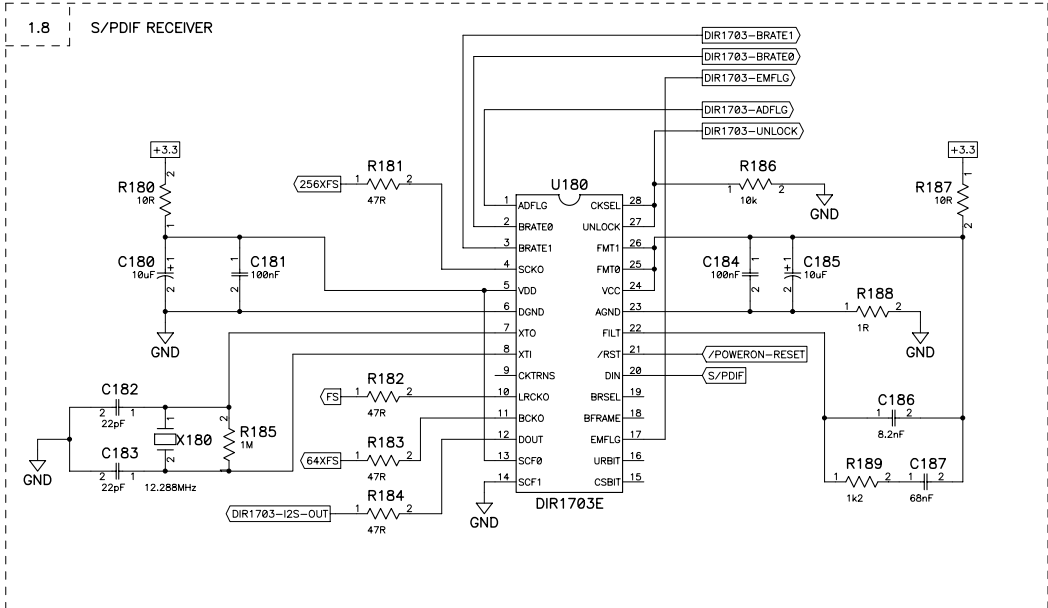
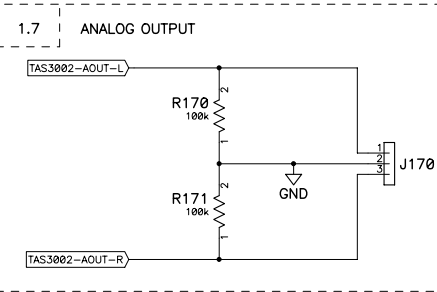
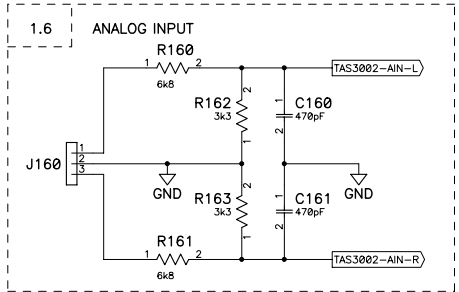
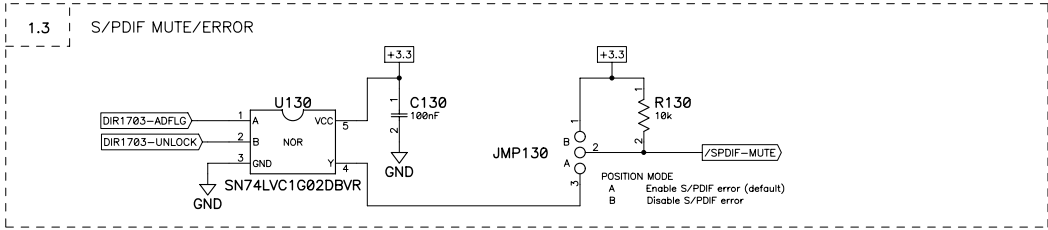
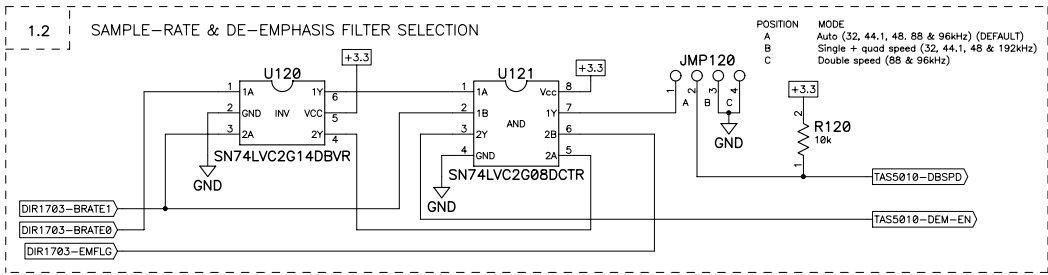
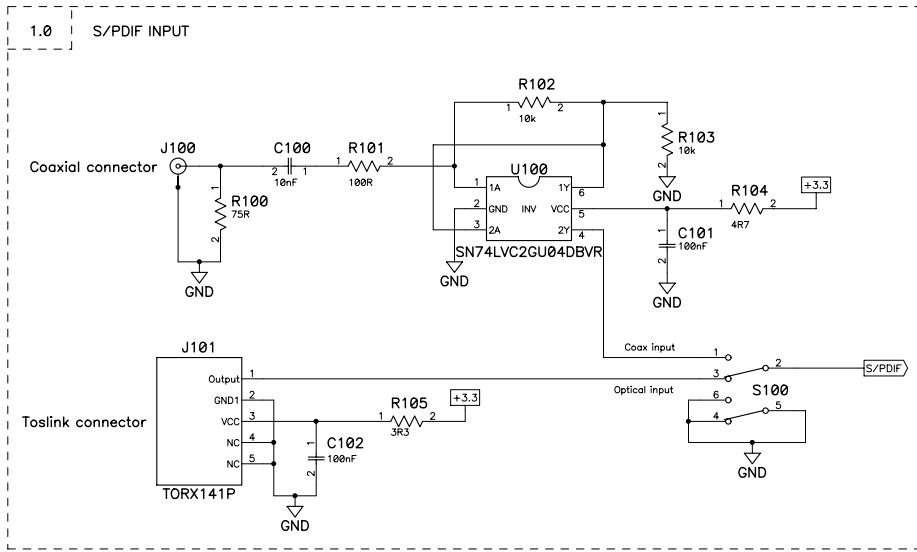

TEXAS INSTRUMENTS

DIGITAL AUDIO GROUP

ALL RIGHTS RESERVED - PATENTS PENDING
TEXAS INSTRUMENTS INCORPORATED

Project: **TAS5010-5112F2EVM**

Size: A2 | Page Title: AUDIO INPUT SECTION

Engineers: Jonas Svendsen

Date: Mon May 24, 2004 | Rev: 3 | Mod: 1 | Sheet: 1 of 7

Filename: P216-SCH-001(5.00).sch | Drawn by: JSV

File Location:

OUTPUT STAGE SECTION

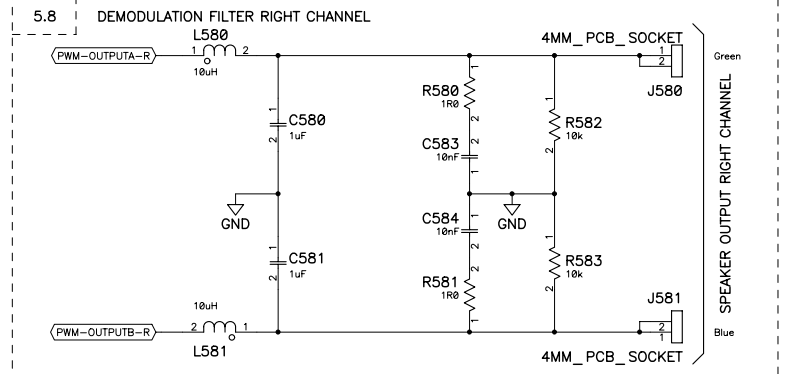
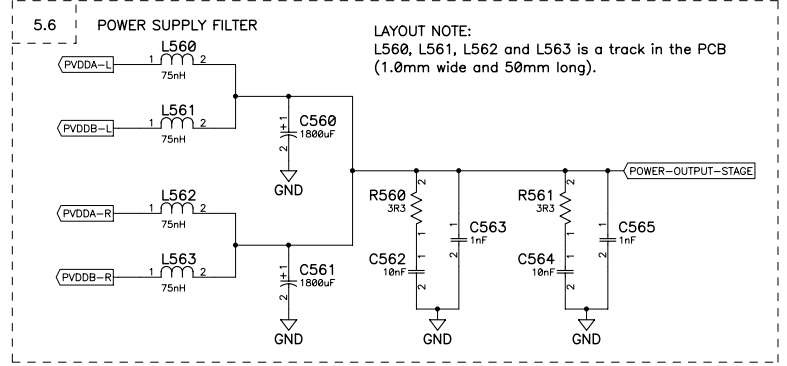
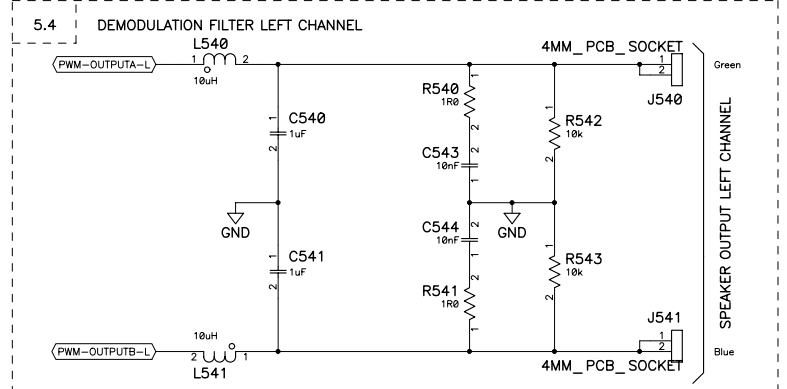
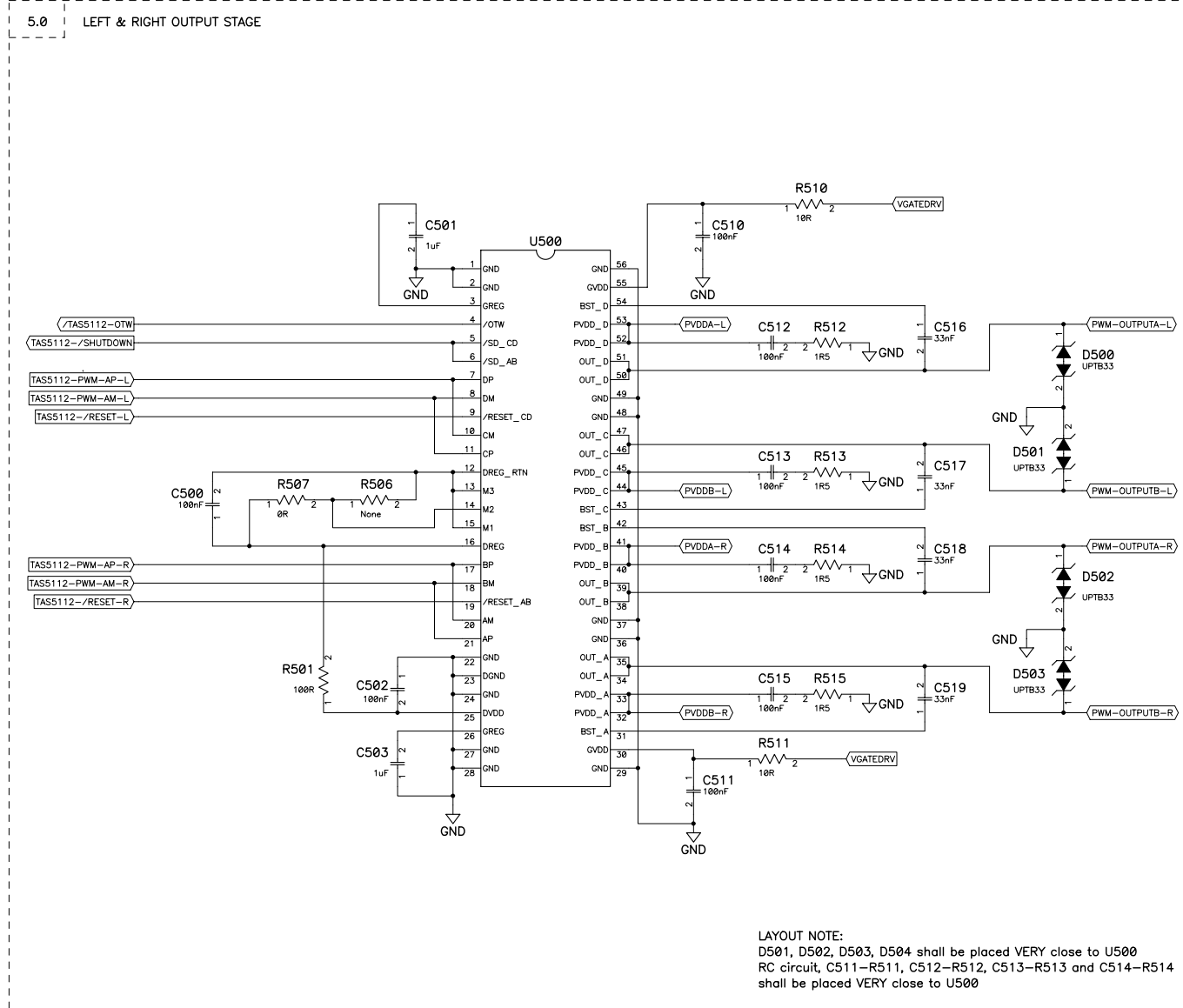

Patents pending in circuitry design and layout (WO99/59241 & WO99/59242).
This circuitry may only be used together with the integrated circuit TAS5112 from Texas Instruments Incorporated.

REFERENCE DESIGN PAGE 2 OF 2

		DIGITAL AUDIO GROUP <small>ALL RIGHTS RESERVED - PATENTS PENDING TEXAS INSTRUMENTS INCORPORATED</small>	
Size: A2	Page Title	OUTPUT STAGE SECTION	
Engineers: Jonas Svendsen			
Date: Mon May 24, 2004	Rev: 3	Mod: 1	Sheet: 5 of 7
File name: P216-SCH-001(5.00).sch		Drawn by: JSV	
File Location:			

PCM TO PWM MODULATOR SECTION

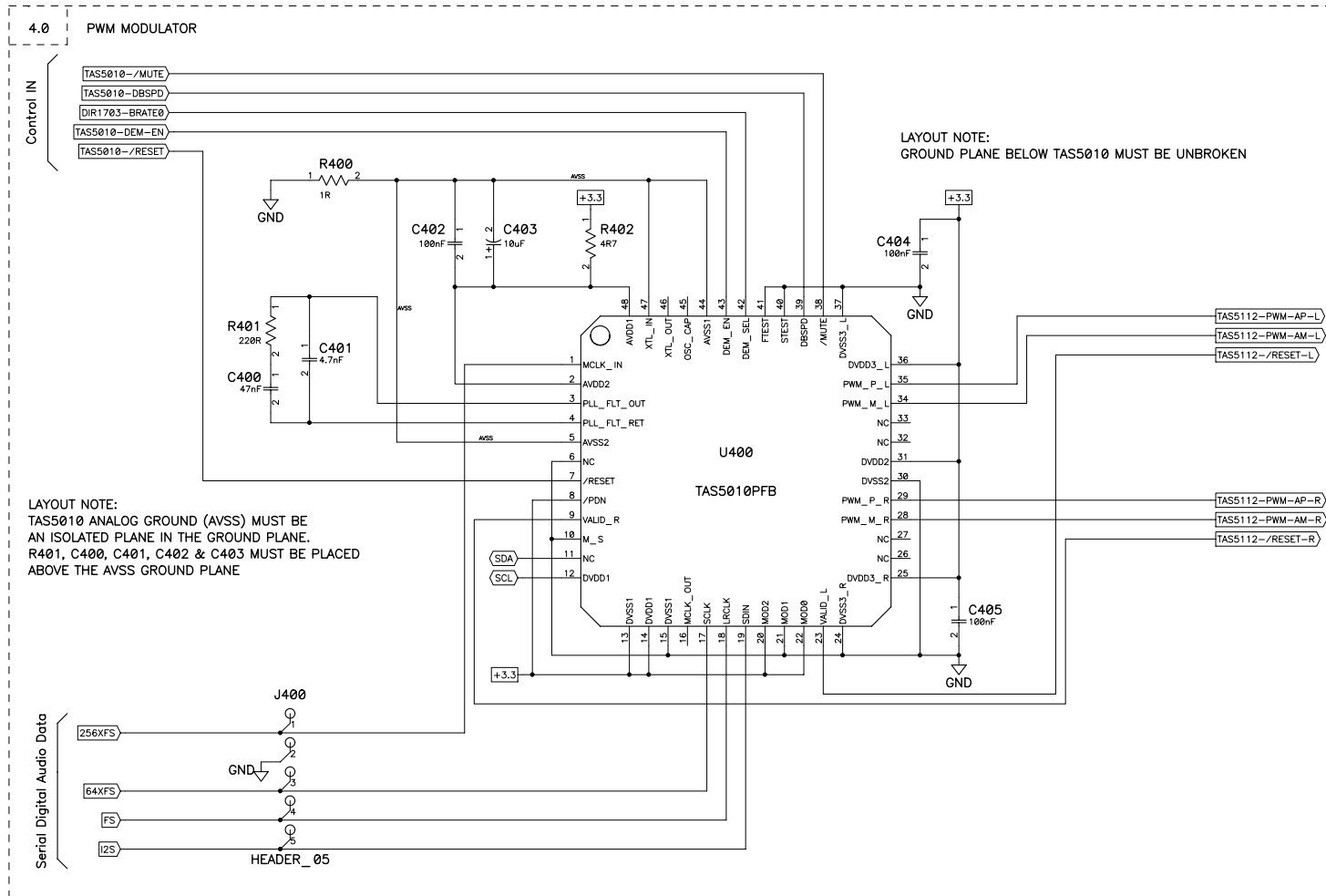

Patents pending in circuitry design and layout (WO99/59241 & WO99/59242).
 This circuitry may only be used together with the integrated circuit TAS5112 from Texas Instruments Incorporated.

REFERENCE DESIGN PAGE 1 OF 2

		TEXAS INSTRUMENTS		DIGITAL AUDIO GROUP	
				ALL RIGHTS RESERVED - PATENTS PENDING TEXAS INSTRUMENTS INCORPORATED	
Project:		TAS5010-5112F2EVM			
Size:	Page Title	PCM TO PWM MODULATOR SECTION			
Engineers: Jonas Svendsen					
Date: Mon May 24, 2004	Rev: 3	Mod: 1	Sheet: 4 of 7		
Filename:		P216-SCH-001(5.00).sch		Drawn by: JSV	
File Location:					

CONTROL SECTION

2.0 PROTECTION CIRCUITRY

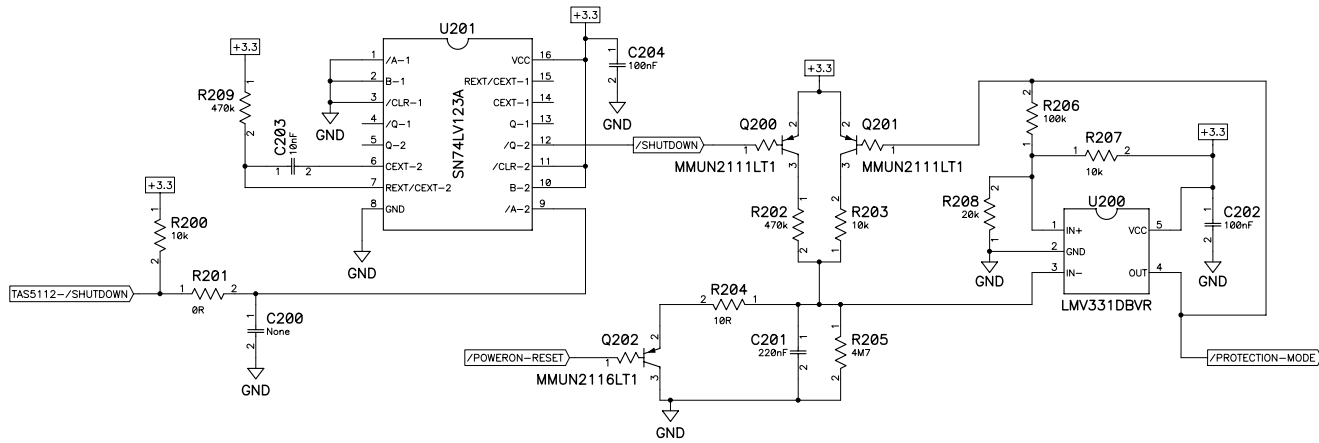

2.2 POWER, WARNINGS & ERROR INDICATORS

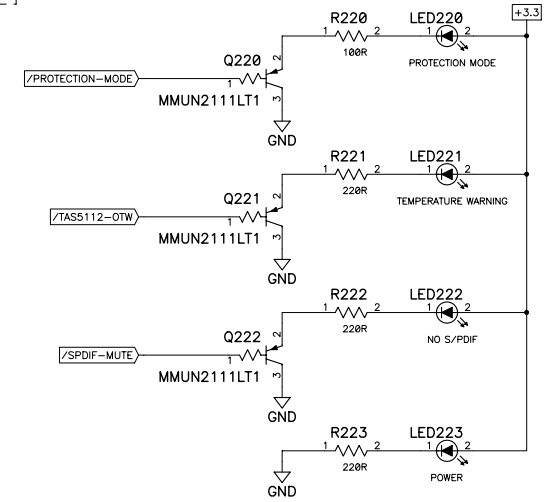

2.4 MUTE & RESET SYSTEM
RESET BUTTON: SEE BLOCK 6.2

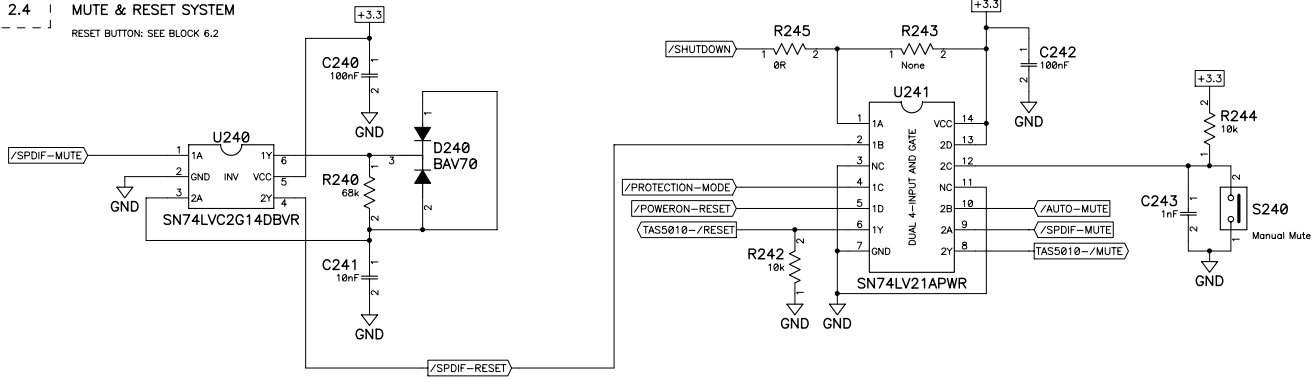

2.7 AUTO MUTE CIRCUITRY

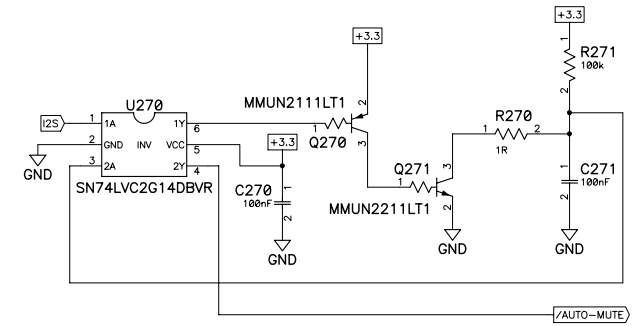

		DIGITAL AUDIO GROUP ALL RIGHTS RESERVED - PATENTS PENDING TEXAS INSTRUMENTS INCORPORATED	
Project: TAS5010-5112F2EVM			
Size: A2	Page Title		CONTROL SECTION
Engineers: Jonas Svendsen			
Date: Mon May 24, 2004	Rev: 3	Mod: 1	Sheet: 2 of 7
Filename: P216-SCH-001(5.00).sch		Drawn by: JSV	
File Location:			

DESIGN LOG

P216-SCH-001 (1.00): Initial Schematic

P216-SCH-001 (2.00): Initial Schematic

P216-SCH-001 (3.00): Added TVS on output stage
Added Pulse extender on shutdown signal
Deleded R500, R508

P216-SCH-001 (4.00): Replaced TVS diode on output stage with bi-directional version
Updated pulse extender pin 9 and 10

P216-SCH-001 (5.00): Board name and information updated

		DIGITAL AUDIO GROUP	
		ALL RIGHTS RESERVED - PATENTS PENDING TEXAS INSTRUMENTS INCORPORATED	
Project: TAS5010-5112F2EVM			
Size: A2	Page Title		DESIGN LOG
Engineers: Jonas Svendsen			
Date: Mon May 24, 2004	Rev: 3	Mod: 1	Sheet: 7 of 7
Filename: P216-SCH-001(5.00).sch		Drawn by: JSV	
File Location:			

DIGITAL AUDIO PROCESSOR SECTION

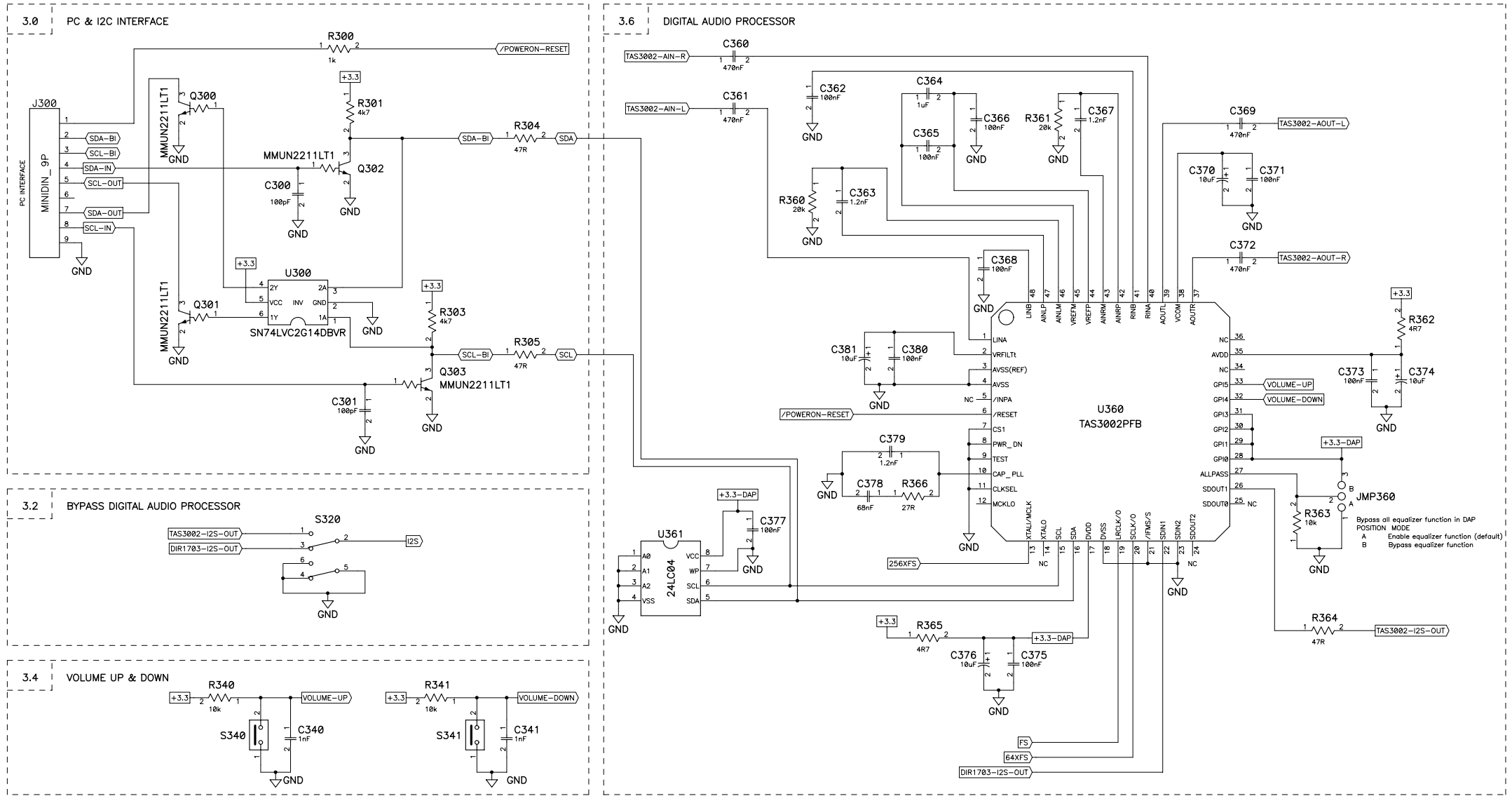

TEXAS INSTRUMENTS

DIGITAL AUDIO GROUP

ALL RIGHTS RESERVED - PATENTS PENDING
TEXAS INSTRUMENTS INCORPORATED

Project: **TAS5010-5112F2EVM**

Size: A2 Page Title DIGITAL AUDIO PROCESSOR SECTION

Engineers: Jonas Svendsen			
Date: Mon May 24, 2004	Rev: 3	Mod: 1	Sheet: 3 of 7
Filename: P216-SCH-001(5.00).sch		Drawn by: JSV	
File Location:			

POWER SUPPLY SECTION

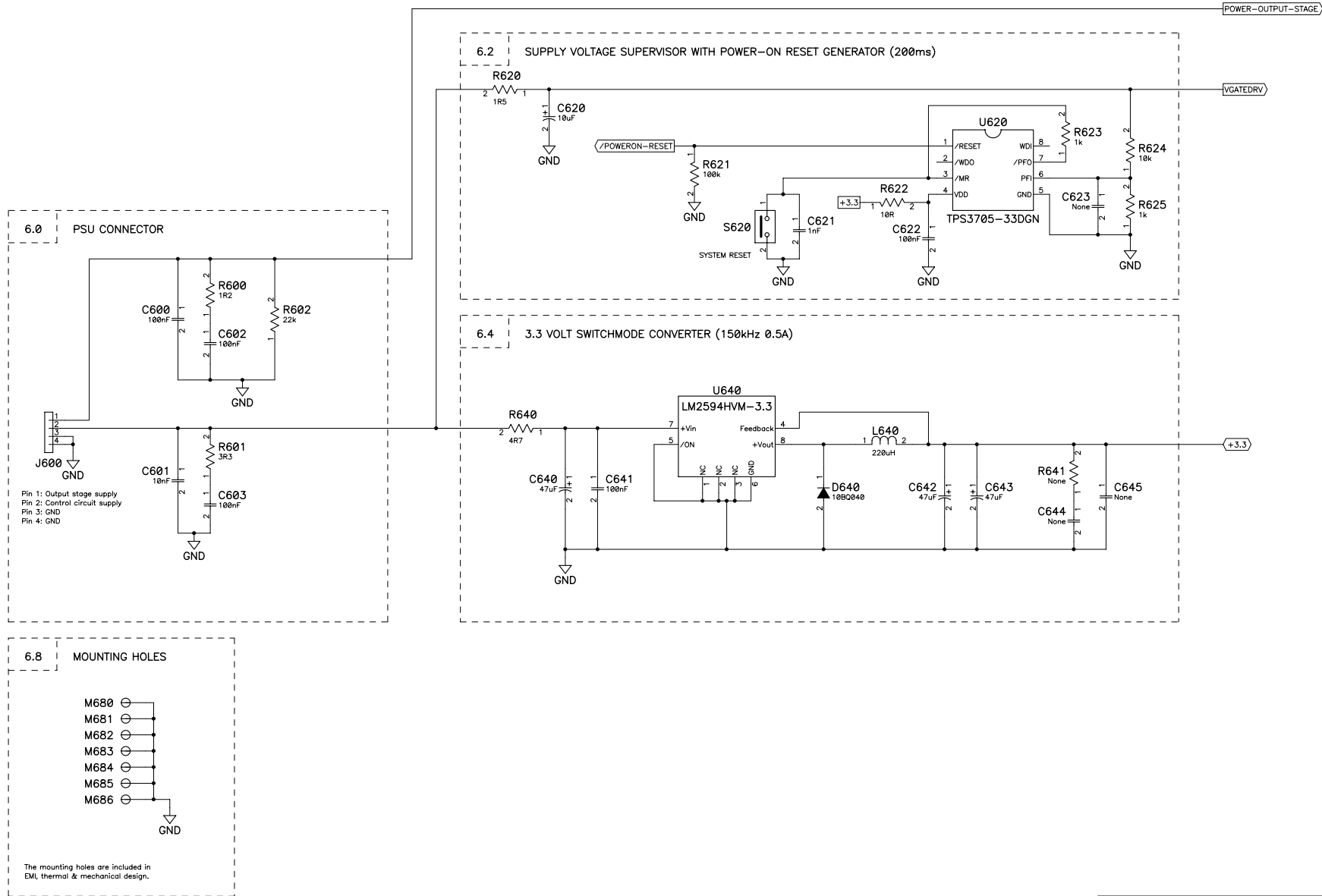

TEXAS INSTRUMENTS		DIGITAL AUDIO GROUP <small>ALL RIGHTS RESERVED - PATENTS PENDING TEXAS INSTRUMENTS INCORPORATED</small>	
Project: TAS5010-5112F2EVM			
Size: A2	Page Title	POWER SUPPLY SECTION	
Engineers: Jonas Svendsen			
Date: Mon May 24, 2004	Rev: 3	Mod: 1	Sheet: 6 of 7
Filename: P216-SCH-001(5.00).sch		Drawn by: JSV	
File Location:			

TAS5010-5112F2EVM Parts List (5.00)



Qty	Part Reference	Value	Housing	Manufacturer Name	Manufacturer p/n 1
1	R602	22k0 1% 100ppm 0.25W metalfilm	1206	Philips	2322 724 62203
1	R105	3R30 1% 100ppm 0.25W metalfilm	1206	Philips	2322 724 63308
1	R100	75R0 1% 100ppm 0.25W metalfilm	1206	Philips	2322 724 67509
4	R542 R543 R582 R583	10k0 1% 100ppm 125mW metalfilm	0805	Philips	2322 734 61003
4	R560 R561 R600 R601	3R30 1% 100ppm 125mW metalfilm	0805	Philips	2322 734 63308
10	R201 R245 R403 R404 R405 R406 R502 R503 R504 R507	0 ohm jumper	0603	BC Components	DCT 0603 jumper
3	R101 R220 R501	100R 5% 200ppm 100mW metalfilm	0603	BC Components	DCT 0603 - 00 5% PA 100R
3	R300 R623 R625	1k00 5% 200ppm 100mW metalfilm	0603	BC Components	DCT 0603 - 00 5% PA 1k00
14	R102 R103 R120 R130 R186 R200 R203 R207 R242 R244 R340 R341 R363 R624	10k0 5% 200ppm 100mW metalfilm	0603	BC Components	DCT 0603 - 00 5% PA 10k0
5	R170 R171 R206 R271 R621	100k 5% 200ppm 100mW metalfilm	0603	BC Components	DCT 0603 - 00 5% PA 100k
1	R185	1M 5% 200ppm 100mW metalfilm	0603	BC Components	DCT 0603 - 00 5% PA 1M00
7	R188 R270 R400 R540 R541 R580 R581	1R0 5% 300ppm 100mW metalfilm	0603	BC Components	DCT 0603 -00 5% PA 1R0
6	R180 R187 R204 R510 R511 R622	10R0 5% 200ppm 100mW metalfilm	0603	BC Components	DCT 0603 -00 5% PA 10R
1	R189	1k20 5% 200ppm 100mW metalfilm	0603	BC Components	DCT 0603 - 00 5% PA 1k20
3	R208 R360 R361	20k0 5% 200ppm 100mW metalfilm	0603	BC Components	DCT 0603 - 00 5% PA 20k0
4	R221 R222 R223 R401	220R 5% 200ppm 100mW metalfilm	0603	BC Components	DCT 0603 -00 5% PA 220R
1	R366	27R0 5% 200ppm 100mW metalfilm	0603	BC Components	DCT 0603 -00 5% PA 27R
2	R162 R163	3k30 5% 200ppm 100mW metalfilm	0603	BC Components	DCT 0603 -00 5% PA 3k30
2	R301 R303	4k70 5% 200ppm 100mW metalfilm	0603	BC Components	DCT 0603 -00 5% PA 4k70
2	R202 R209	470k 5% 200ppm 100mW metalfilm	0603	BC Components	DCT 0603 -00 5% PA 470k
1	R205	4M70 5% 200ppm 100mW metalfilm	0603	BC Components	DCT 0603 -00 5% PA 4M70
4	R104 R362 R365 R402	4R70 5% 300ppm 100mW metalfilm	0603	BC Components	DCT 0603 -00 5% PA 4R70
7	R181 R182 R183 R184 R304 R305 R364	47R0 5% 200ppm 100mW metalfilm	0603	BC Components	DCT 0603 -00 5% PA 47R0
2	R160 R161	6k80 5% 200ppm 100mW metalfilm	0603	BC Components	DCT 0603 -00 5% PA 6k80
1	R240	68k0 5% 200ppm 100mW metalfilm	0603	BC Components	DCT 0603 -00 5% PA 68k0
5	R512 R513 R514 R515 R620	1R50 5% 100ppm 250mW metalfilm	RC3715	Beychlag	MMA0204-100 5% BL 1R5C
1	R640	4R70 1% 50ppm 250mW metalfilm	RC3715	Beychlag	MMA0204-50 1% BL 4R70
3	C562 C564 C601	10nF 50V 20% X7R	0805	Philips	2222 600 xxx36
10	C271 C510 C511 C512 C513 C514 C515 C602 C603 C641	100nF 50V 20% X7R	0805	Philips	2222 580 16741
3	C364 C501 C503	1uF 16V 20% X7R	0805	KEMET	C0805C105M4RAC
1	C201	220nF 20% 16V X7R	0805	KEMET	C0805C224M4RAC
4	C516 C517 C518 C519	33nF 50V 20% X7R	0805	Philips	2222 580 16634
4	C360 C361 C369 C372	470nF 16V 20% X7R	0805	Philips	2222 780 16758
2	C563 C565	1nF 50V 2% NP0	0805	Philips	2222 861 14102
8	C180 C185 C370 C374 C376 C381 C403 C620	10uF 16V 20% LYT	LY4x5SMD	Panasonic	ECE V 1C A 100 SR
7	C100 C203 C241 C543 C544 C583 C584	10nF 50V 20% X7R	0603	KEMET	C0603C103M5RAC
25	C101 C102 C130 C181 C184 C202 C204 C240 C242 C270 C362 C365 C366 C368 C371 C373 C375 C377 C380 C402 C404 C405 C500 C502 C622	100nF 16V 20% X7R	0603	KEMET	C0603C104M4RAC
3	C363 C367 C379	1.2nF 50V 10% X7R	0603	KEMET	C0603C122M5RAC
1	C401	4.7nF 50V 20% X7R	0603	KEMET	C0603C473M5RAC
1	C400	47nF 16V 20% X7R	0603	KEMET	C0603C473M2RAC
2	C187 C378	68nF 16V 20% X7R	0603	KEMET	C0603C683M2RAC
1	C186	8.2nF 50V 10% X7R	0603	KEMET	C0603C822M5RAC
2	C300 C301	100pF 50V 10% NP0	0603	KEMET	C0603C101K5GAC
4	C243 C340 C341 C621	1nF 10% 50V NP0	0603	KEMET	C0603C102K5GAC
2	C182 C183	22pF 10% 50V NP0	0603	KEMET	C0603C220K5GAC
2	C160 C161	470pF 10% 50V NP0	0603	KEMET	C0603C471K5GAC
2	C560 C561	1800uF 35V 20% 22mR 2.6A	C7M5PD18	Panasonic	EEUFC1V182
3	C640 C642 C643	47uF 35V 20% low esr	C1PD2_5	RUBYCON	35YXF47MY0611
4	C540 C541 C580 C581	1uF 63V 10% polyester	C3B2	Wima	MKS4 1uF 63V 10% PCM7.5
1	L640	220uH 20% 0.5A 0.39R		CoilCraft	DT3316P-224
4	L540 L541 L580 L581	10uH 4.4A 20% 24mR		TAIYO YUDEN	LHFP13BB100M
1	D240	70V/250mA Small signal dual diode A-C-A	SOT-23	General Semiconductor	BAV70
1	D640	1A/40V Schottky diode	SMB	International Rectifier	10MQ040N
4	D500 D501 D502 D503	33V/3.3A TVS Diode	POWERMITE	Microsemi	UPTB33
1	LED220	RED 10mA LED SMD	0603P	Toshiba	TLSU1008
1	LED223	GREEN 10mA LED SMD	0603P	Toshiba	TLGU1008
2	LED221 LED222	YELLOW 10mA LED SMD	0603P	Toshiba	TLYU1008
6	Q200 Q201 Q220 Q221 Q222 Q270	PNP 50V/0.1A Dig. Trans.(Rb=10k Rbe=10k)	SOT-23	ON Semiconductor / Motorola	MMUN2111LT1
1	Q202	PNP 50V/0.1A Dig. Trans.(Rb=4k7)	SOT-23	ON Semiconductor / Motorola	MMUN2116LT1
5	Q271 Q300 Q301 Q302 Q303	NPN 50V/0.1A Dig. Trans.(Rb=10k Rbe=10k)	SOT-23	ON Semiconductor / Motorola	MMUN2211LT1
1	U180	Digital Audio interface receiver	SSOP-28	Texas Instruments	DIR1703E

TAS5010-5112F2EVM Parts List (5.00)



1	U360	Codec DAP with ADC/DAC	S-PQFP-G38	Texas Instruments	TAS3002PFB
1	U400	PCM to PWM DAP 192kHz 92dB DR	TQFP48	Texas Instruments	TAS5010PFB
1	U500	Stereo Digital Audio PWM Power Output Stage	HTSSOP56	Texas Instruments	TAS5112ADFD
1	U200	Differential Comparator	SOT23-5	Texas Instruments	LMV331IDBVR
1	U130	Single 2-input NOR gate, LVC	SOT23-5	Texas Instruments	SN74LVC1G02DBVR
1	U100	Dual Inverter, LVC		Texas Instruments	SN74LVC2GU04DBVR
1	U121	Dual AND gate, LVC	MSOP8	Texas Instruments	SN74LVC2G08DCTR
4	U120 U240 U270 U300	Dual Schmitt-Trigger Inverter, LVC		Texas Instruments	SN74LVC2G14DBVR
1	U241	Dual 4-input AND gate, LV	TSSOP14	Texas Instruments	SN74LV21APWR
1	U201	Dual Retrigr. Monostab. Multivib. LV	TSSOP16	Texas Instruments	SN74LV123APWR
1	U361	4K I2C serial EEPROM	SO8	Microchip	24LC04BSN
1	U620	3.3V Supp. Volt. Supervisor, 200ms Delay	MSOP8	Texas Instruments	TPS3705-33DGN
1	U640	3V3/0.5A Buck Converter	SO8	National Semiconductor	LM2594HVM-3.3V
1	J101	TOSLINK Receiver, 3.3V		Toshiba	TORX141P
5	SCREW01 SCREW02 SCREW03 SCREW04 SCREW05	M3x6, Pan head, Pozidriv, A2 screw		Bossard	BN 31108 M3x6
2	SCREW06 SCREW07	M3x8, Pan head, Pozidriv, A2 screw		Bossard	BN 31108 M3x8
5	WASHER01 WASHER02 WASHER03 WASHER04 WASHER05	M3 stainless steel washer		Bossard	BN 670
4	WASHER06 WASHER07 WASHER08 WASHER09	M3 White Nylon Washer (OD9.0 ID3 t0.8)		Bossard	BN1075 M3
5	STAND-OFF01 STAND-OFF02 STAND-OFF03 STAND-OFF04 STAND-OFF05	M3x10 aluminum stand offs		Ettinger	05.03.108
2	JMP130 JMP360	3 pin 2.54mm Pitch Header	MX3SI	Molex	90120-0123
2	J160 J170	3 pin 2.54mm Pitch Header, friction lock	MX3SI	Molex	22-27-2031
1	JMP120	4 pin 2.54mm Pitch Header	MX4SI	Molex	90120-0124
1	J600	4 Pin 3.96mm Pitch Header	MY4S	JST	B 4P-VH
1	J100	Phono RCA connector		MONACOR	T-709
2	J541 J581	4mm PCB mount socket blue		Deltron	571-0200
2	J540 J580	4mm PCB mount socket green		Deltron	571-0400
1	J300	9 pol mini din with shield		CUI STACK	MD-90SM
1	X180	12.288MHz Crystal HC49		C-MAG	12.288MHz HC49/4H
4	S240 S340 S341 S620	Tact switch, SPMT, 12V/50mA		Panasonic	EVQ-PPDA25
2	S100 S320	Switch DPDT on-on pcb mount - SUBMINI		NKK-Nikkai	G-22-AP
1	PCB	TAS5010-5112F2EVM Printed Circuit Board (ver. 4.00)		Printline	P216-PCB-001(4.00)
1	MECH01	Heatsink with 3 fins (78x35x32mm)		A.K.S.	TIC-HSINK-003 (1.00)
1	TPAD01	Self-adhesive thermal pad, DFD package, 15 mill SILPAD2000 (6x14mm)		Valentin	TIC-TPAD-001 (1.00)

TAS5010-5112F2EVM PCB SPECIFICATION

BOARD IDENTIFICATION:	P216-PCB-001 (4.00)
BOARD TYPE:	DOUBLE-SIDED PLATED-THROUGH BOARD
LAMINATE TYPE:	FR4
LAMINATE THICKNESS:	1.6 mm
COPPER THICKNESS:	70µm (INCL. PLATING EXTERIOR LAYER)
COPPER PLATING OF HOLES:	>25µm
MINIMUM HOLE DIAMETER	0.3 mm
SILKSCREEN COMPONENT SIDE:	WHITE – REMOVE SILKSCREEN FROM SOLDER AREA & PRE-TINNED AREAS
SILKSCREEN SOLDER SIDE:	None
SOLDER MASK COMPONENT SIDE:	GREEN
SOLDER MASK SOLDER SIDE:	GREEN
PROTECTIVE COATING:	SOLDER COATING AND CHEMICAL SILVER ON FREE COPPER
ELECTRICAL TEST:	PCB MUST BE ELECTRICAL TESTED
MANUFACTURED TO:	PERFAG 2E (www.perfag.dk)
APERTURE TABLE:	PERFAG 10A (www.perfag.dk)
BOARD SIZE:	80 x 160 mm

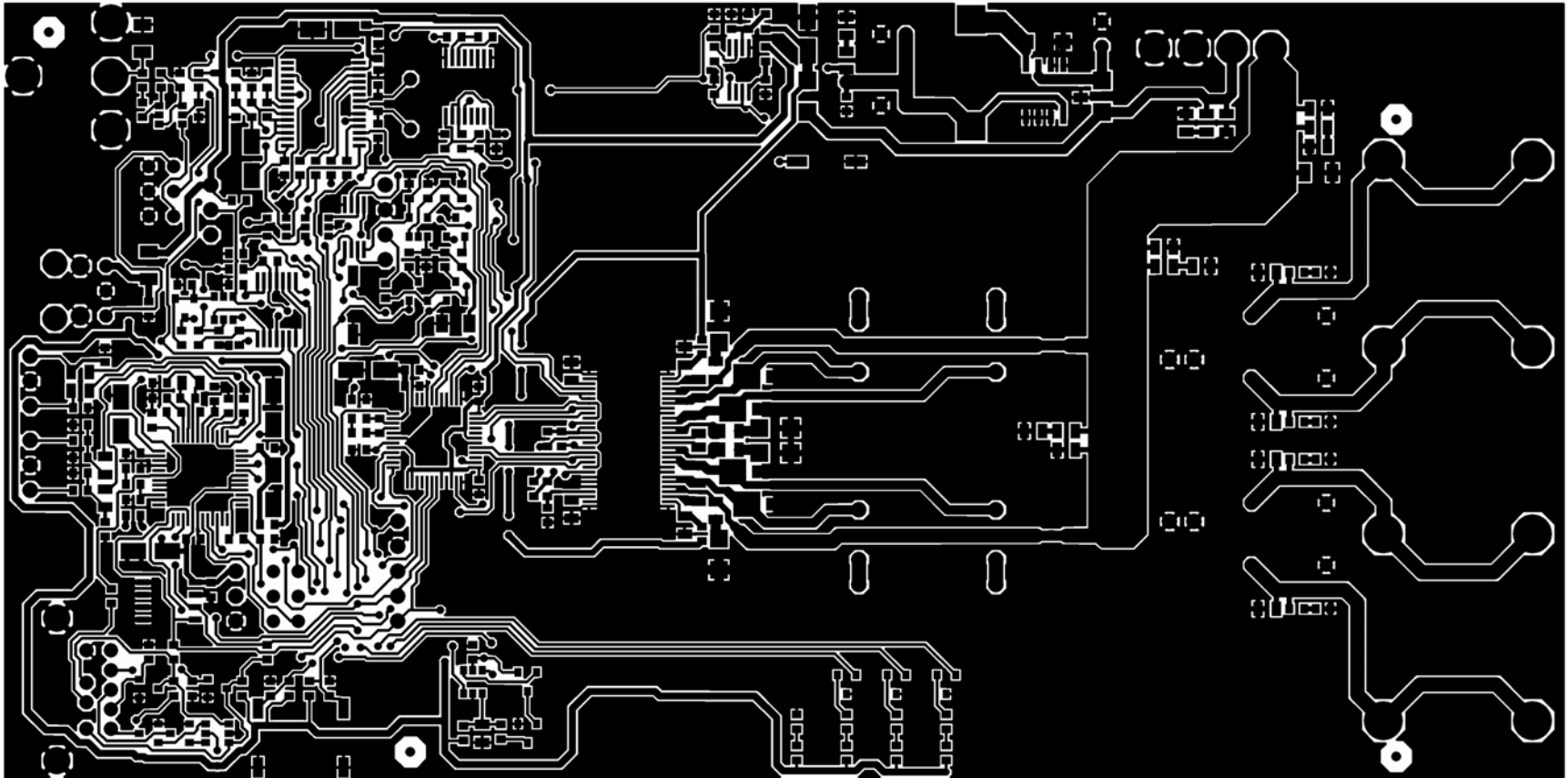

TOP-SIDE

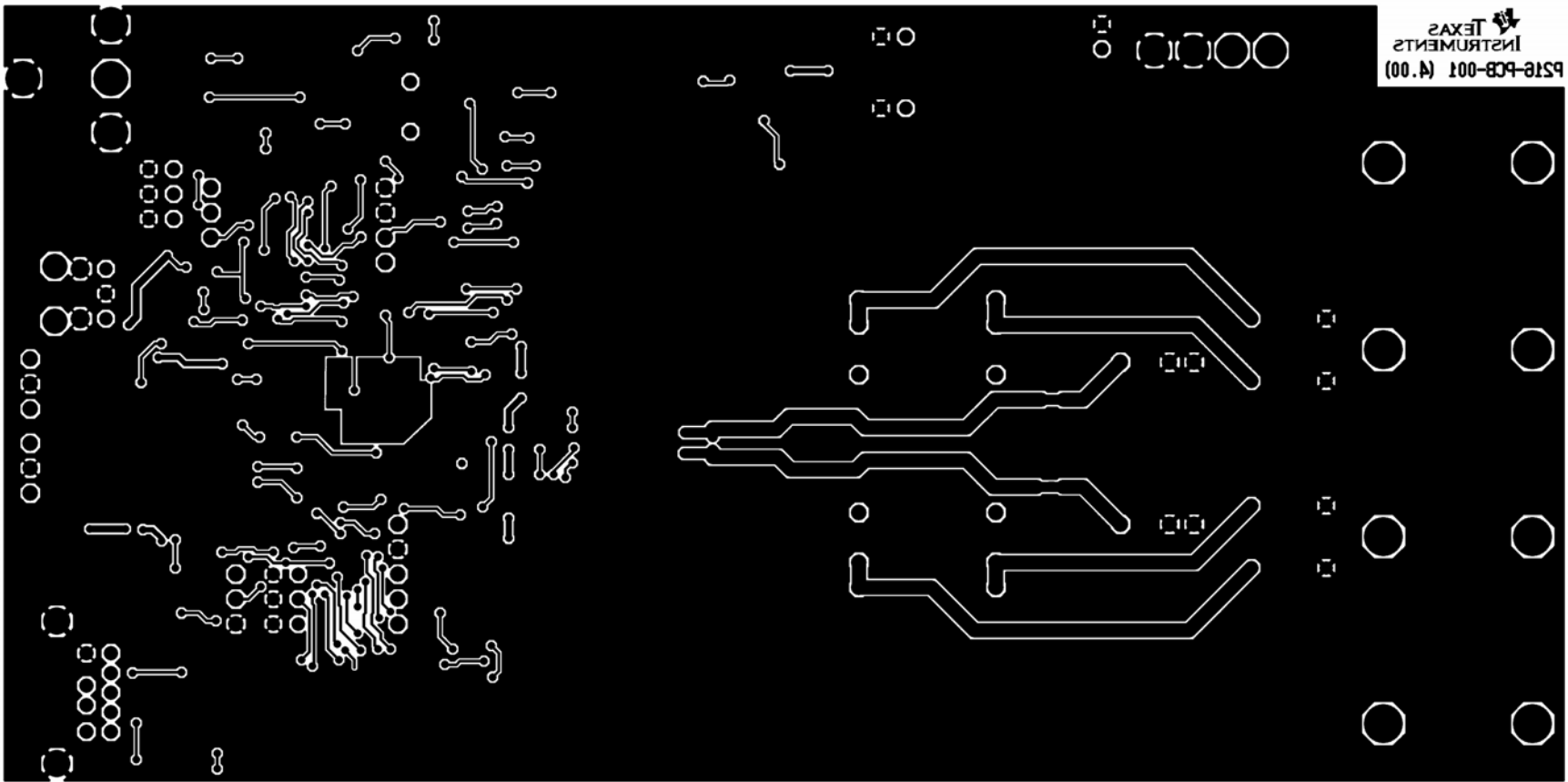

BOTTOM-SIDE

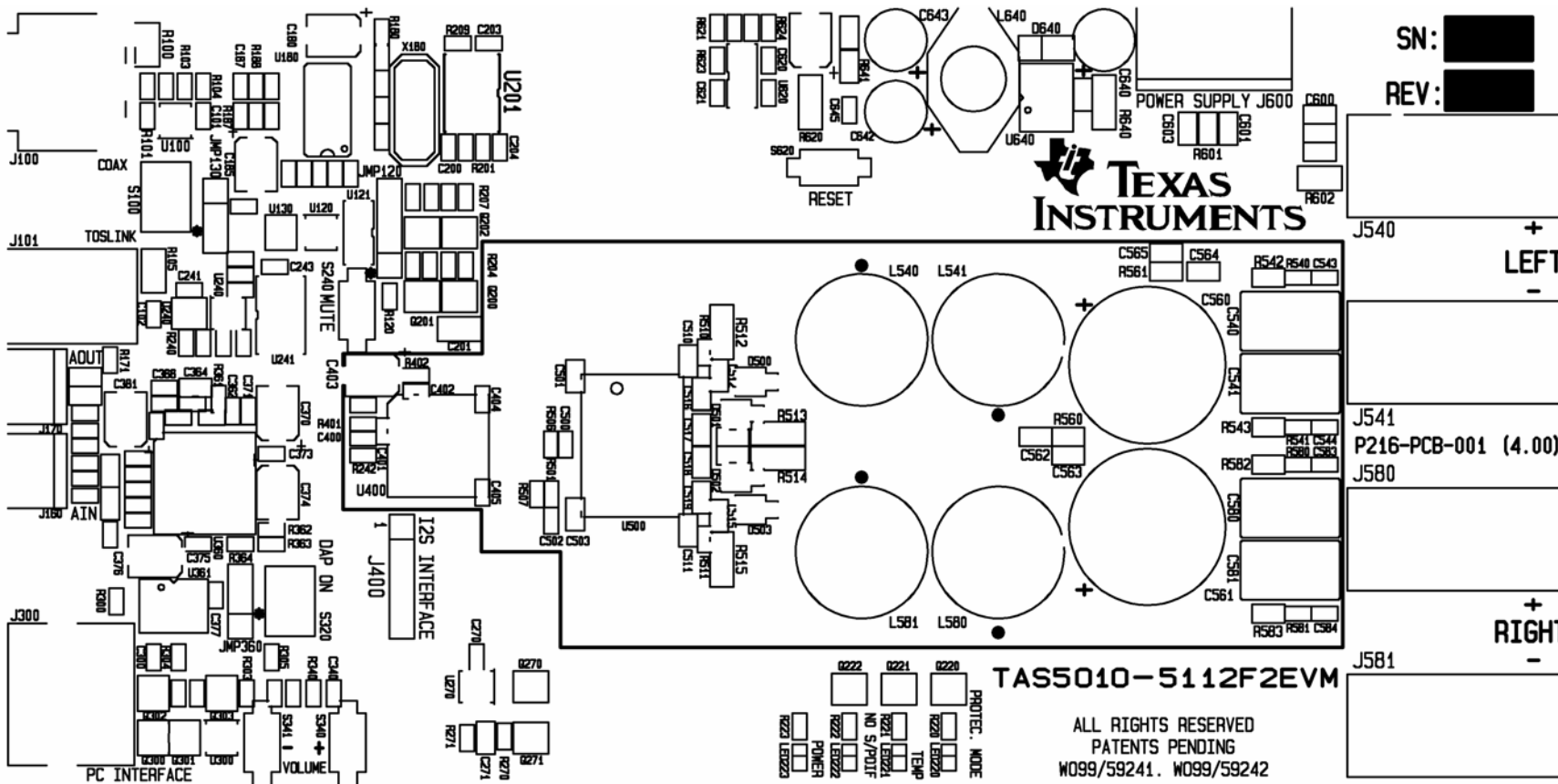

SILK-SCREEN

**TIC-HSINK-003
Heat Sink with 3 Fins (35 mm.)**

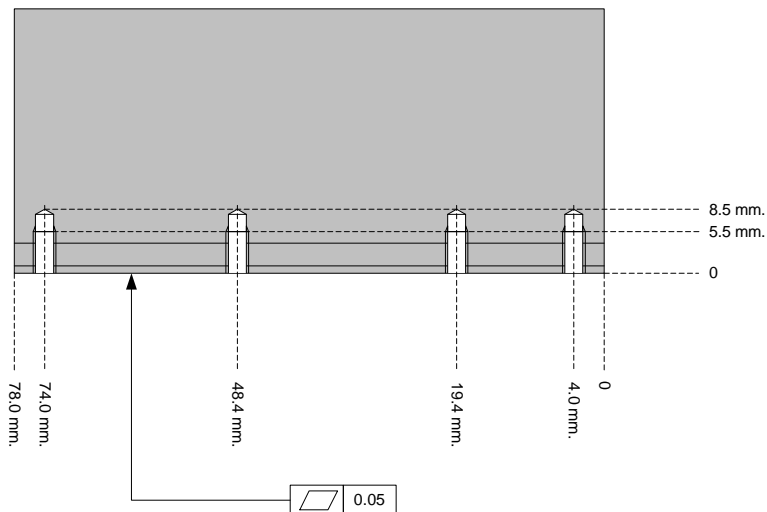
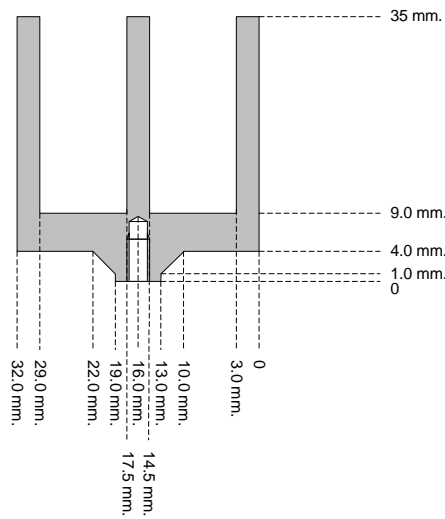

MATERIAL: ALUMINIUM

INTERNAL SCREW THREADS: M3

SURFACE: GLASS BLOWED, FREE OF SHARP EDGES

SURFACE TREATMENT: BLACK ANODIZED

TOLERANCES: +/- 0.1mm.

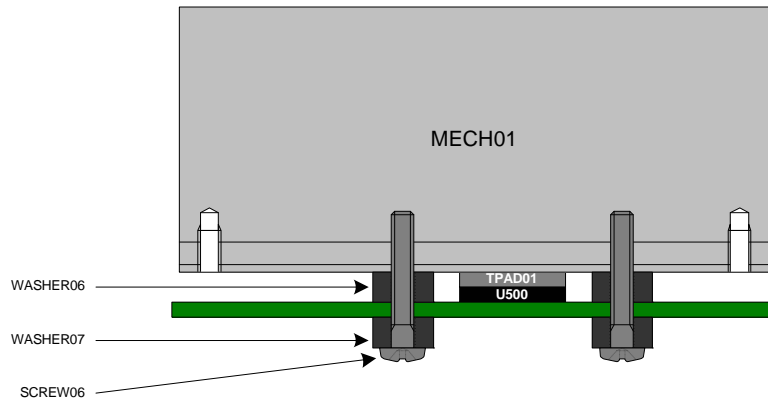

TORQUE-LIMITING SCREWDRIVER HAVE TO BE USED DURING ASSEMBLY OF HEAT SINK (TORQUE LIMITED TO 0.3 N*m).

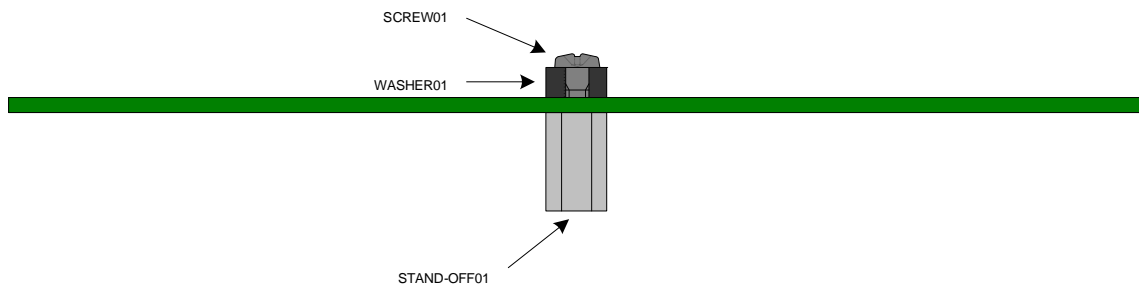

MOUNT STAND OFF'S IN ALL FIVE POSSIBLE POSITIONS ON THE PCB

TAS5010-5112F2EVM Engineering Change Order

Affected Documents

Board Revision: REV 5

Title	Document Number	Issue
Schematic	P216-SCH-001	5.00
Printed Circuit Board	P216-PCB-001	4.00
Bill Of Material	P216-LST-001	5.00

Part list changes from version

Type	Value	Part Reference	Old P/N	New P/N
Changed	-	S240 S340 S341 S620	Panasonic EVQ-PPDA25	Panasonic EVQ5PN04K

Please update board revision to "6".

IMPORTANT NOTICE

Texas Instruments Incorporated and its subsidiaries (TI) reserve the right to make corrections, modifications, enhancements, improvements, and other changes to its products and services at any time and to discontinue any product or service without notice. Customers should obtain the latest relevant information before placing orders and should verify that such information is current and complete. All products are sold subject to TI's terms and conditions of sale supplied at the time of order acknowledgment.

TI warrants performance of its hardware products to the specifications applicable at the time of sale in accordance with TI's standard warranty. Testing and other quality control techniques are used to the extent TI deems necessary to support this warranty. Except where mandated by government requirements, testing of all parameters of each product is not necessarily performed.

TI assumes no liability for applications assistance or customer product design. Customers are responsible for their products and applications using TI components. To minimize the risks associated with customer products and applications, customers should provide adequate design and operating safeguards.

TI does not warrant or represent that any license, either express or implied, is granted under any TI patent right, copyright, mask work right, or other TI intellectual property right relating to any combination, machine, or process in which TI products or services are used. Information published by TI regarding third-party products or services does not constitute a license from TI to use such products or services or a warranty or endorsement thereof. Use of such information may require a license from a third party under the patents or other intellectual property of the third party, or a license from TI under the patents or other intellectual property of TI.

Reproduction of TI information in TI data books or data sheets is permissible only if reproduction is without alteration and is accompanied by all associated warranties, conditions, limitations, and notices. Reproduction of this information with alteration is an unfair and deceptive business practice. TI is not responsible or liable for such altered documentation. Information of third parties may be subject to additional restrictions.

Resale of TI products or services with statements different from or beyond the parameters stated by TI for that product or service voids all express and any implied warranties for the associated TI product or service and is an unfair and deceptive business practice. TI is not responsible or liable for any such statements.

TI products are not authorized for use in safety-critical applications (such as life support) where a failure of the TI product would reasonably be expected to cause severe personal injury or death, unless officers of the parties have executed an agreement specifically governing such use. Buyers represent that they have all necessary expertise in the safety and regulatory ramifications of their applications, and acknowledge and agree that they are solely responsible for all legal, regulatory and safety-related requirements concerning their products and any use of TI products in such safety-critical applications, notwithstanding any applications-related information or support that may be provided by TI. Further, Buyers must fully indemnify TI and its representatives against any damages arising out of the use of TI products in such safety-critical applications.

TI products are neither designed nor intended for use in military/aerospace applications or environments unless the TI products are specifically designated by TI as military-grade or "enhanced plastic." Only products designated by TI as military-grade meet military specifications. Buyers acknowledge and agree that any such use of TI products which TI has not designated as military-grade is solely at the Buyer's risk, and that they are solely responsible for compliance with all legal and regulatory requirements in connection with such use.

TI products are neither designed nor intended for use in automotive applications or environments unless the specific TI products are designated by TI as compliant with ISO/TS 16949 requirements. Buyers acknowledge and agree that, if they use any non-designated products in automotive applications, TI will not be responsible for any failure to meet such requirements.

Following are URLs where you can obtain information on other Texas Instruments products and application solutions:

Products

Amplifiers	amplifier.ti.com
Data Converters	dataconverter.ti.com
DSP	dsp.ti.com
Clocks and Timers	www.ti.com/clocks
Interface	interface.ti.com
Logic	logic.ti.com
Power Mgmt	power.ti.com
Microcontrollers	microcontroller.ti.com
RFID	www.ti-rfid.com
RF/IF and ZigBee® Solutions	www.ti.com/lprf

Applications

Audio	www.ti.com/audio
Automotive	www.ti.com/automotive
Broadband	www.ti.com/broadband
Digital Control	www.ti.com/digitalcontrol
Medical	www.ti.com/medical
Military	www.ti.com/military
Optical Networking	www.ti.com/opticalnetwork
Security	www.ti.com/security
Telephony	www.ti.com/telephony
Video & Imaging	www.ti.com/video
Wireless	www.ti.com/wireless

Mailing Address: Texas Instruments, Post Office Box 655303, Dallas, Texas 75265
Copyright © 2008, Texas Instruments Incorporated