

# ***Differential Op Amp Single-Supply Design Techniques***

---

Bruce Carter

High Performance Linear

## **ABSTRACT**

There is a lot of confusion about how to operate a fully differential op amp from a single power supply. This application note describes how to select the correct dc operating point of a fully differential op amp.

## **1 Introduction**

Fully differential op amps are often misapplied. The presence of the  $V_{OCM}$  pin lures a lot of designers into a sense of complacency. They believe—mistakenly—that injecting the dc operating point at the  $V_{OCM}$  pin is all that is required to set the dc operating point. Nothing could be further from the truth. An incorrect dc operating point is just as bad with fully differential op amps as it is with single ended op amps. While the circuit may operate, it will consume more power than is necessary.

## **2 Bipolar Operation—Simple to Understand**

Circuits where bipolar power supplies are available are the easiest to understand. The example shown in Figure 1 is a unity gain stage, operating from a  $\pm 5\text{-V}$  power supply. The input is  $\pm 7 V_{AC}$ , which was selected because it is close to clipping the output. In this way, any abnormalities in the circuit operating point that contribute to clipping will be apparent in subsequent variations of the circuit. Termination resistors are not shown in these examples, because they are irrelevant for the analysis of the examples.

Figure 1, and other circuit diagrams in this document, are a bit *busy*. PSpice™ simulation circuits are not as nice for presentation as the output of other CAD programs, but it is important to show the voltages and currents. For those viewing the document in color, brown flags show voltages, red flags show currents.

The op amp used, a THS4131, is drawing slightly over 14 mA on its two power pins. The dc operating point of the circuit is very close to zero volts, and there is very little current being drawn from the source, or flowing through the feedback and gain resistors. Total power dissipation of the circuit is 0.142 W.

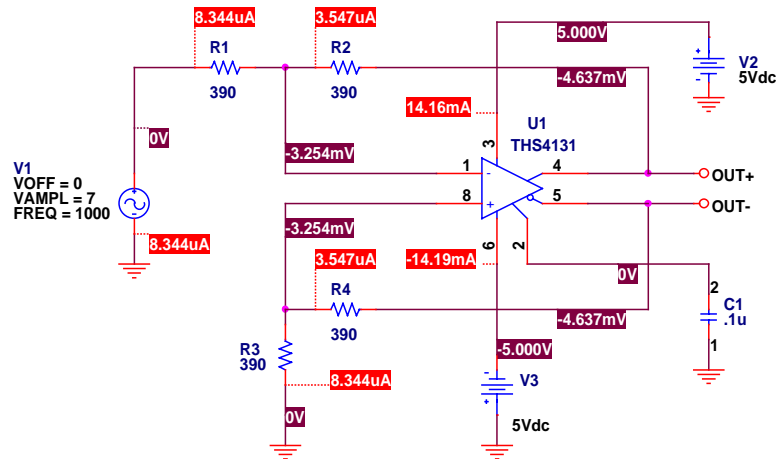

**Figure 1. Bipolar Operation of a Fully Differential Op Amp**

The transient response of the circuit shown in Figure 1 requires a bit of explanation. Data collection is delayed until 10 mS to allow *turnon* transients to settle out. This delay is more important in later examples, when capacitors must be charged for ac-coupled applications. The input amplitude, which is  $\pm 7 V_{AC}$ , is mirrored in the output. The common mode point of the amplifier is zero volts. Because the input is also centered on zero volts, the output is centered on zero volts. Although the output appears to violate the voltage rails (14 V<sub>PP</sub> from a ten-volt power supply), it actually does not—because the plotted function is  $(V_{OUT+}) - (V_{OUT-})$ . Individual outputs will have a swing of  $\pm 3.5 V_{AC}$ , 180° out of phase.

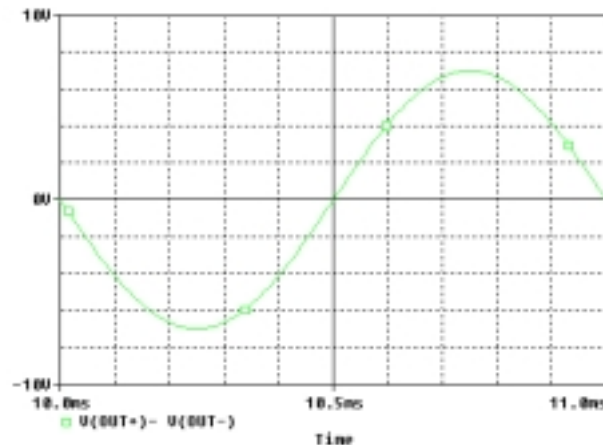

**Figure 2. Transient Response for Circuit of Figure 1**

### 3 A Very Common Misapplication

The circuit in Figure 3, traditionally used for single-supply fully differential op amps, is not correct. It will *work*, which is why it is commonly employed.

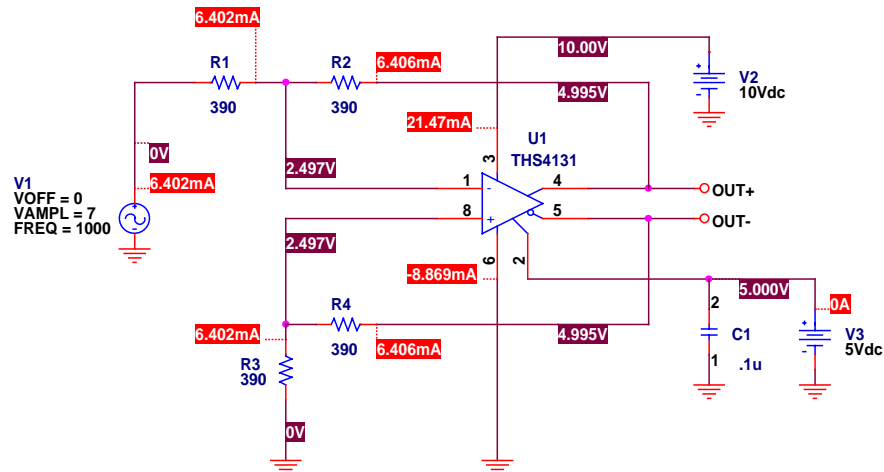
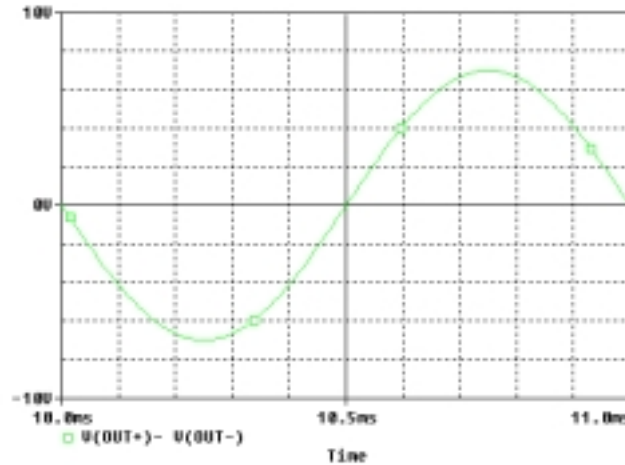

**Figure 3. A Common Misapplication**

There are some real problems with this circuit:

- The connections from the op amp outputs through R1 and R2, and through R3 and R4 to ground (and virtual ground), form voltage dividers to ground. These voltage dividers put approximately 2.5 V on the op amp inputs, instead of the common mode point of the amplifier, which is 5 V.
- Direct current flows through the two feedback pathways, amounting to 6.4 mA of additional circuit current through each feedback path.
- The op amp draws approximately 21.5 mA of current from the positive supply, and 8.7 mA from the negative supply. This means that the internal portions of the op amp supporting the positive voltage swing are consuming 2.5 times the current of the negative portions to pull the output towards 10 V. They will correspondingly heat up more, unbalancing the thermal characteristics of the die itself. While this will probably not burn out the chip, the thermal gradients cannot possibly help stability and accuracy of the circuit.
- The input voltage source driving the circuit must source 6.4 mA of current. This is a substantial load, and it may require an additional buffer to supply the current.
- Total power dissipation of the circuit is 0.2151 W instead of 0.142 W. This is a 50% increase over the bipolar case.
- Beware of the power rating of very small resistors such as 0402 and 0201. While the currents may appear small, the current values shown in the schematic are only at dc. Currents will change with the ac waveform. Circuits employing gain, with smaller values of input resistor—combined with thermal derating—may exceed the power rating of the resistor. Regardless of the power rating, heating resistors will change value according to their thermal drift, reducing accuracy. Hot resistors also contribute more thermal noise to the circuit.

The output is the same as before, showing the full output swing  $\pm 7 V_{AC}$ . The 5-V<sub>DC</sub> common mode point of the amplifier is subtracted out of the graph in Figure 4 by the function  $(V_{OUT+}) - (V_{OUT-})$ , leaving only the ac response. Individual outputs will have a 5-V offset and a swing of  $\pm 3.5 V_{AC}$ , 180° out of phase. Future examples are similar, and this comment applies to them as well.



**Figure 4. Transient Response for Circuit of Figure 3**

## 4 Correct AC-Coupled Application

The circuit of Figure 3 can be modified easily to balance the currents and establish the correct dc operating point. All that is required is to place coupling capacitors in two locations as shown in Figure 5. The capacitor value shown is rather large—but only because the frequency is low.

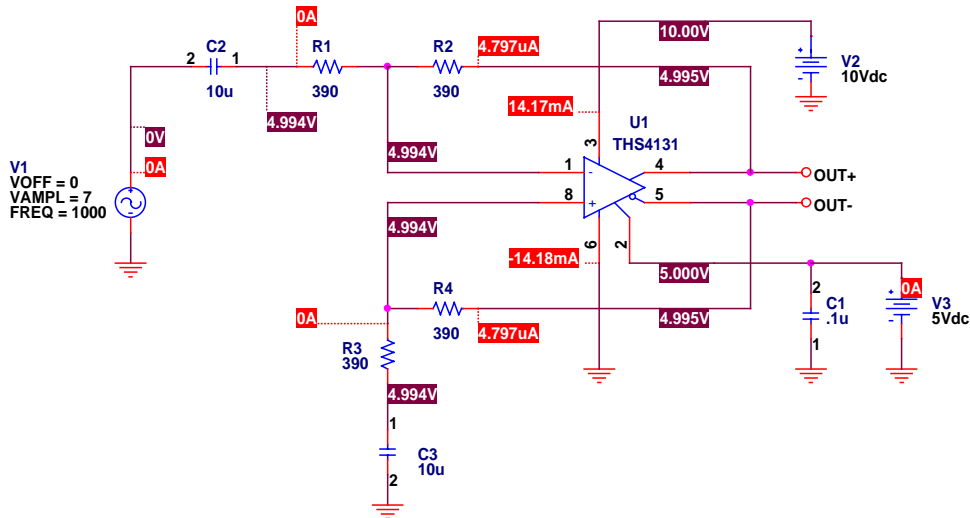
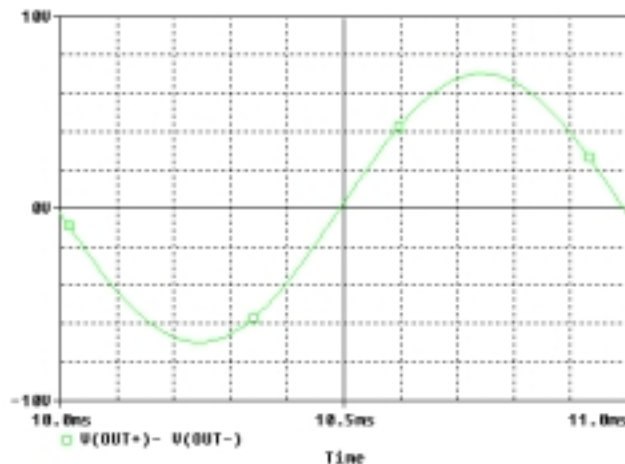

**Figure 5. Correct AC-Coupled Application**

Advantages of this configuration include:

- The common mode point is again 5 VDC, and now both the inverting and noninverting inputs are also at the common mode point.
- Both the positive and negative power pins of the IC now draw the same amount of current, which is about 14.2 mA. This is the same current level as the bipolar power supply case.
- No current is drawn from the input source.
- Currents through feedback and input resistors are very low.
- Total power dissipation of the circuit is down to 0.142 W, the same as the bipolar power supply case.

The transient response again shows the same voltage swing, except that it is slightly changed in phase. This is due to the coupling capacitors.



**Figure 6. Transient Response for Circuit of Figure 5**

## 5 DC-Coupled Applications

AC-coupling is fine for communication systems that do not have to include dc in the frequency response. The coupling capacitors produce high-pass characteristics, blocking dc. The situation becomes more complicated when the system has to be dc accurate. DC op amp applications are notoriously problematic, because the designer has to include dc gain as well as ac gain in their calculations. This example is a unity gain circuit, which simplifies things considerably.

The key to balancing the dc operating point of the circuit is to supply a potential equal to  $V_{OCM}$  to both the source and input to the second feedback path. This is accomplished in Figure 7 by assuming a dc offset of 5 V on the input. In other applications, single-ended op amp offset circuits may be required to shift the dc level of the signal to the correct  $V_{OCM}$  level.

The other feedback circuit is connected to the same source of  $V_{OCM}$  that is connected to the  $V_{OCM}$  input of the op amp circuit. This is problematical, because the circuit will draw current from this source of  $V_{OCM}$ . Figure 9 shows the current drawn as a function of the output voltage level (Figure 8). Data converter  $V_{REF}$  outputs are not designed for this level of current, and they must be buffered by an op amp buffer. The Texas Instruments *Rail Splitter* IC, the TLE 2426, is an excellent way to set the dc reference point of this circuit. If the TLE2426 (or some other independent source) is employed as a source of  $V_{OCM}$  and dc reference, it should be connected to the  $V_{OCM}$  input of the fully differential op amp, it should be connected to the indicated feedback path, and it should also be used as an external reference source for the data converter.

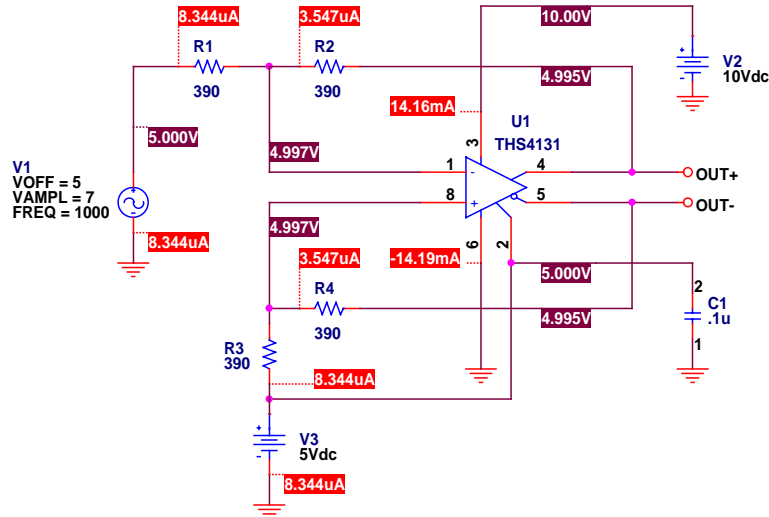

**Figure 7. DC Coupled Application**

Total power dissipation of the circuit is 0.142E-01 W, the same as the bipolar case. The circuit current will be increased, however, by the contribution from the source of  $V_{OCM}$ .

The transient response, shown in Figure 8, shows the same output response as the examples above.

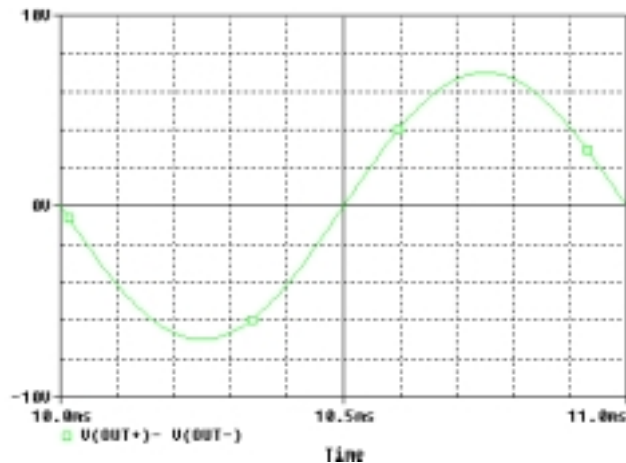

**Figure 8. Transient Response for Circuit of Figure 7**

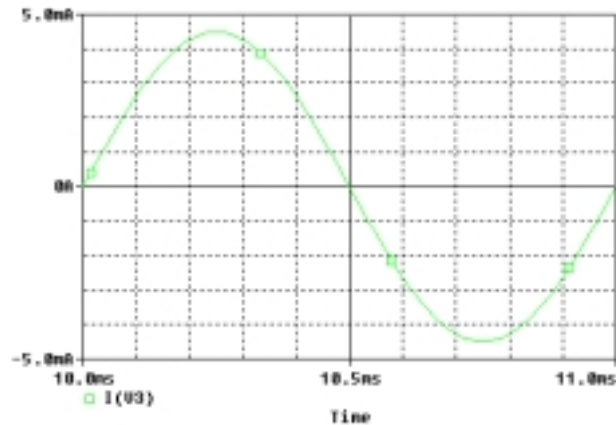

Figure 9. Current Draw From  $V_{OCM}$

## 6 Conclusions

Setting the correct dc operating point of a circuit containing a fully differential op amp does not need to be any more complex than for a single-ended op amp. The presence of a  $V_{OCM}$  input, however, has served to confuse the issue and caused otherwise savvy designers to misapply fully differential op amps, causing an increase in current. This misapplication is hidden in the fact that the circuit appears to work, although it is likely that performance is compromised in subtle ways. The only clue that something is wrong is that the current will increase when compared to the same op amp used with bipolar supplies. Setting the proper dc operating point requires ac coupling capacitors or attention to the dc level of both input points of the circuit.

## IMPORTANT NOTICE

Texas Instruments Incorporated and its subsidiaries (TI) reserve the right to make corrections, modifications, enhancements, improvements, and other changes to its products and services at any time and to discontinue any product or service without notice. Customers should obtain the latest relevant information before placing orders and should verify that such information is current and complete. All products are sold subject to TI's terms and conditions of sale supplied at the time of order acknowledgment.

TI warrants performance of its hardware products to the specifications applicable at the time of sale in accordance with TI's standard warranty. Testing and other quality control techniques are used to the extent TI deems necessary to support this warranty. Except where mandated by government requirements, testing of all parameters of each product is not necessarily performed.

TI assumes no liability for applications assistance or customer product design. Customers are responsible for their products and applications using TI components. To minimize the risks associated with customer products and applications, customers should provide adequate design and operating safeguards.

TI does not warrant or represent that any license, either express or implied, is granted under any TI patent right, copyright, mask work right, or other TI intellectual property right relating to any combination, machine, or process in which TI products or services are used. Information published by TI regarding third-party products or services does not constitute a license from TI to use such products or services or a warranty or endorsement thereof. Use of such information may require a license from a third party under the patents or other intellectual property of the third party, or a license from TI under the patents or other intellectual property of TI.

Reproduction of information in TI data books or data sheets is permissible only if reproduction is without alteration and is accompanied by all associated warranties, conditions, limitations, and notices. Reproduction of this information with alteration is an unfair and deceptive business practice. TI is not responsible or liable for such altered documentation.

Resale of TI products or services with statements different from or beyond the parameters stated by TI for that product or service voids all express and any implied warranties for the associated TI product or service and is an unfair and deceptive business practice. TI is not responsible or liable for any such statements.

### Mailing Address:

Texas Instruments  
Post Office Box 655303  
Dallas, Texas 75265