

bq25012 single-chip, Li-ion charger and dc/dc converter for Bluetooth® headsets

By **Lingyin Zhao** (Email: lzhaot@ti.com)

Application Engineer, Portable Power Management

Introduction

Highly integrated charger and dc/dc converter ICs have become more and more desirable as portable power management technology continues to advance. These ICs not only support size reduction of portable devices but also incorporate more functionality and enhance performance in diagnostics, monitoring, control, and protection.

As an example, a typical Bluetooth headset needs a rechargeable battery (and thus a battery charger) and a 1.8-V dc/dc converter to power the core chip. With small size, light weight, and low cost being the major concerns, the bq25012 is an ideal solution for this application. A single-chip 3.5 × 4.5-mm QFN package incorporates a linear charger with dual inputs for both the ac adapter and the USB, and a dc/dc converter with integrated FETs saves board space and reduces system design time. Figure 1 shows a typical application circuit with a 1.8-V, 100-mA power converter and a 500-mA linear battery charger using the bq25012.

Single-cell, Li-ion battery charger

The bq25012 offers an integrated power MOSFET and charge controller with programmable charge current up to 500 mA for single-cell, Li-ion battery applications. It

charges the battery and powers the system from either the ac adapter or the USB with autonomous power-source selection. When the V_{CC} supply is removed, the bq2501x automatically enters sleep mode with reverse blocking protection to extend the battery runtime.

The bq25012 charges the battery in three phases with high-accuracy current and voltage regulation: precharge, constant current, and constant voltage. Charging is terminated based on minimum current. An internal charge timer provides an additional safety feature for charge termination. The bq2501x automatically recharges the battery if the battery voltage falls below an internal voltage threshold, which is 100 mV below the voltage regulation point.

The STAT1 and STAT2 open-drain outputs indicate various charger and battery conditions, while the \overline{PG} pin indicates whether the ac adapter is present. The digital input (\overline{CE}) is used to enable and disable the charging process.

High-efficiency dc/dc converter

The high-efficiency, synchronous switching dc/dc converter with integrated power MOSFETs is capable of supplying up to 150 mA. The bq25012 has fixed dc/dc converter output voltage at 1.8 V, while the bq25010 has adjustable output voltage from 0.7 to 4.2 V. They use the battery voltage, V_{BAT} , as their input. The synchronous pulse width modulation (PWM)

Figure 1. bq25012 application circuit

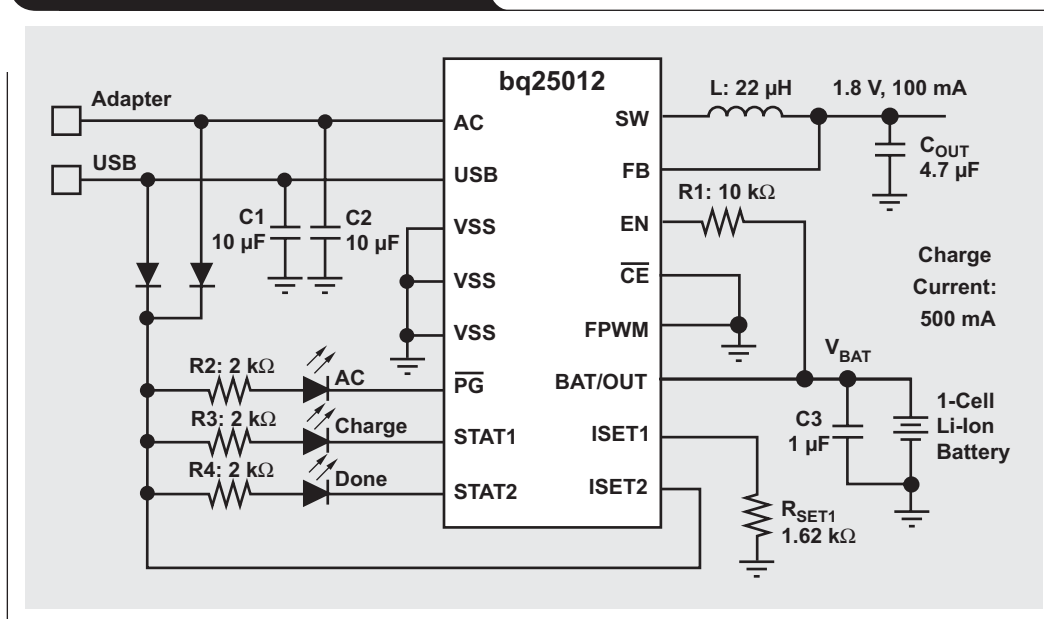

controller operates at 1 MHz, minimizing the size of the filter inductor and capacitor. The undervoltage lockout circuit prevents the converter from turning on the switch or rectifier MOSFET at low input voltages or under undefined conditions.

During PWM operation, the converter uses a unique, fast-response voltage-mode-controller scheme with input voltage feedforward to achieve good line and load regulation, allowing the use of small ceramic input and output capacitors. As the load current decreases, the converter enters power-save, or pulse frequency modulation (PFM), mode. In this mode the converter operates with reduced switching frequency and with a minimum quiescent current to maintain high efficiency. However, in cases when PFM is not desirable, driving the forced PWM pin high overrides power-save mode and forces the dc/dc converter to remain in the PWM mode.

Figure 2 shows measured dc/dc converter efficiency when the bq25012 EVM is used.

Design example

Requirements

Adapter voltage: 5 V

Battery pack: Single Li-ion, 1800 mAh

Battery regulation voltage: 4.2 V

Fast-charge current: 500 mA

Precharge and termination current: 50 mA

dc/dc converter output voltage: 1.8 V/100 mA

Determine the inductor L

Given 40% ripple current, the inductance when

$V_{IN} = V_{BAT_max}$ and $V_{IN} = V_{BAT_min}$ is

$$L = \frac{V_{BAT_max} - V_{OUT}}{\Delta I_L} \times \frac{V_{OUT}}{V_{BAT_max}} \times \frac{1}{f_S} = 25.7 \mu\text{H}.$$

Select $L = 22 \mu\text{H}$.

The inductor saturation current should be larger than the peak current to prevent inductor saturation. Select the Taiyo Yuden LBC2016T220M inductor (22 μH , 165 mA, 0806).

Determine the output capacitor C_{OUT}

To achieve optimum loop stability, the resonant frequency f_0 , composed of the inductor and output capacitor of the dc/dc converter, is approximately 16 kHz.

$$C_{OUT} = \frac{1}{(2\pi f_0)^2 L} = 4.5 \times 10^{-6} \text{ (farads)}$$

Select a 4.7- μF , 6.3-V, 0603 ceramic capacitor.

Determine current setting resistor R_{SET1}

With $V_{SET} = 2.5 \text{ V}$ and $K_{SET} = 320 \text{ V/A}$,

$$R_{SET1} = \frac{V_{SET} K_{SET}}{I_{Fast-charge}} = \frac{2.5 \times 320}{0.5} = 1.6 \text{ k}\Omega.$$

Select 1%, 1.62-k Ω resistors.

Figure 2. Efficiency vs. I_{OUT}

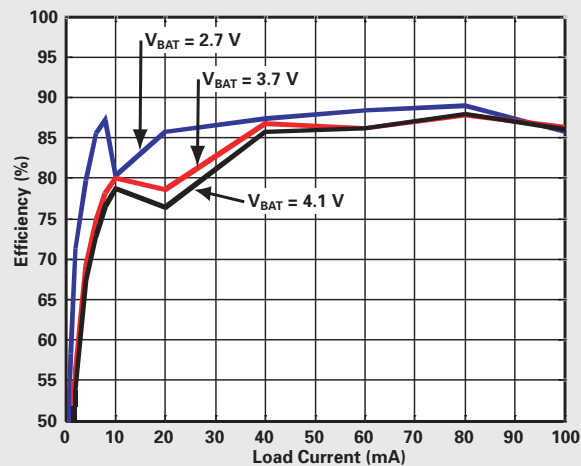

(a) Power-save mode ($V_{OUT} = 1.8 \text{ V}$, $T = 27^\circ\text{C}$)

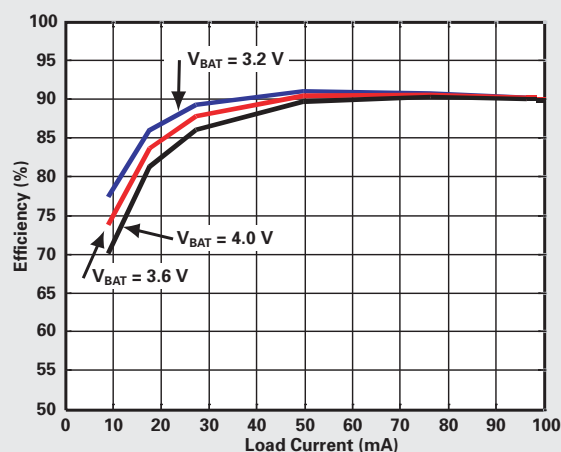

(b) Forced PWM ($V_{OUT} = 1.8 \text{ V}$, $T = 22^\circ\text{C}$)

Determine USB charge current

The ISET2 pin determines the charge current for the USB port (high = 500 mA, low = 100 mA, high-Z = disable USB charge).

Conclusion

The bq25012 fully integrates a single-cell Li-ion battery linear charger up to 500 mA and a high-efficiency, 1-MHz, synchronous switching step-down dc/dc converter. The small size, high efficiency, and easy design make this a simple and versatile IC to use for many portable power applications such as Bluetooth headsets and MP3 players.

Related Web sites

power.ti.com

www.ti.com/sc/device/bq25010

www.ti.com/sc/device/bq25012

IMPORTANT NOTICE

Texas Instruments Incorporated and its subsidiaries (TI) reserve the right to make corrections, modifications, enhancements, improvements, and other changes to its products and services at any time and to discontinue any product or service without notice. Customers should obtain the latest relevant information before placing orders and should verify that such information is current and complete. All products are sold subject to TI's terms and conditions of sale supplied at the time of order acknowledgment.

TI warrants performance of its hardware products to the specifications applicable at the time of sale in accordance with TI's standard warranty. Testing and other quality control techniques are used to the extent TI deems necessary to support this warranty. Except where mandated by government requirements, testing of all parameters of each product is not necessarily performed.

TI assumes no liability for applications assistance or customer product design. Customers are responsible for their products and applications using TI components. To minimize the risks associated with customer products and applications, customers should provide adequate design and operating safeguards.

TI does not warrant or represent that any license, either express or implied, is granted under any TI patent right, copyright, mask work right, or other TI intellectual property right relating to any combination, machine, or process in which TI products or services are used. Information published by TI regarding third-party products or services does not constitute a license from TI to use such products or services or a warranty or endorsement thereof. Use of such information may require a license from a third party under the patents or other intellectual property of the third party, or a license from TI under the patents or other intellectual property of TI.

Reproduction of information in TI data books or data sheets is permissible only if reproduction is without alteration and is accompanied by all associated warranties, conditions, limitations, and notices. Reproduction of this information with alteration is an unfair and deceptive business practice. TI is not responsible or liable for such altered documentation.

Resale of TI products or services with statements different from or beyond the parameters stated by TI for that product or service voids all express and any implied warranties for the associated TI product or service and is an unfair and deceptive business practice. TI is not responsible or liable for any such statements.

Following are URLs where you can obtain information on other Texas Instruments products and application solutions:

Products

Amplifiers	amplifier.ti.com
Data Converters	dataconverter.ti.com
DSP	dsp.ti.com
Interface	interface.ti.com
Logic	logic.ti.com
Power Management	power.ti.com
Microcontrollers	microcontroller.ti.com

Applications

Audio	www.ti.com/audio
Automotive	www.ti.com/automotive
Broadband	www.ti.com/broadband
Digital control	www.ti.com/digitalcontrol
Military	www.ti.com/military
Optical Networking	www.ti.com/opticalnetwork
Security	www.ti.com/security
Telephony	www.ti.com/telephony
Video & Imaging	www.ti.com/video
Wireless	www.ti.com/wireless

TI Worldwide Technical Support

Internet

TI Semiconductor Product Information Center Home Page
support.ti.com

TI Semiconductor KnowledgeBase Home Page
support.ti.com/sc/knowledgebase

Product Information Centers

Americas

Phone	+1(972) 644-5580	Fax	+1(972) 927-6377
Internet/Email	support.ti.com/sc/pic/americas.htm		

Europe, Middle East, and Africa

Phone			
Belgium (English)	+32 (0) 27 45 54 32	Netherlands (English)	+31 (0) 546 87 95 45
Finland (English)	+358 (0) 9 25173948	Russia	+7 (4) 95 98 10 701
France	+33 (0) 1 30 70 11 64	Spain	+34 902 35 40 28
Germany	+49 (0) 8161 80 33 11	Sweden (English)	+46 (0) 8587 555 22
Israel (English)	180 949 0107	United Kingdom	+44 (0) 1604 66 33 99
Italy	800 79 11 37		
Fax	+49 (0) 8161 80 2045		
Internet	support.ti.com/sc/pic/euro.htm		

Japan

Fax			
International	+81-3-3344-5317	Domestic	0120-81-0036
Internet/Email			
International	support.ti.com/sc/pic/japan.htm		
Domestic	www.tij.co.jp/pic		

Asia

Phone			
International	+886-2-23786800		
Domestic	Toll-Free Number		
Australia	1-800-999-084	Malaysia	1-800-80-3973
China	800-820-8682	New Zealand	0800-446-934
Hong Kong	800-96-5941	Philippines	1-800-765-7404
India	+91-80-41381665 (Toll)	Singapore	800-886-1028
Indonesia	001-803-8861-1006	Taiwan	0800-006800
Korea	080-551-2804	Thailand	001-800-886-0010
Fax	+886-2-2378-6808	Email	tiasia@ti.com
Internet	support.ti.com/sc/pic/asia.htm		
			ti-china@ti.com

C062706

Safe Harbor Statement: This publication may contain forward-looking statements that involve a number of risks and uncertainties. These "forward-looking statements" are intended to qualify for the safe harbor from liability established by the Private Securities Litigation Reform Act of 1995. These forward-looking statements generally can be identified by phrases such as "TI believes," "expects," "anticipates," "foresees," "forecasts," "estimates" or other words or phrases of similar import. Similarly, such statements herein that describe the company's products, business strategy, outlook, objectives, plans, intentions or goals also are forward-looking statements. All such forward-looking statements are subject to certain risks and uncertainties that could cause actual results to differ materially from those in forward-looking statements. Please refer to TI's most recent Form 10-K for more information on the risks and uncertainties that could materially affect future results of operations. We disclaim any intention or obligation to update any forward-looking statements as a result of developments occurring after the date of this publication.

Trademarks: The Bluetooth word mark and logos are owned by the Bluetooth SIG, Inc., and any use of such marks by Texas Instruments is under license. All other trademarks are the property of their respective owners.

Mailing Address: Texas Instruments
Post Office Box 655303
Dallas, Texas 75265

© 2006 Texas Instruments Incorporated

SLYT255