

Using the USB APLL on the TMS320VC5506/C5507/C5509A

Monideep Mukherjee

ABSTRACT

This document describes how to switch to and program the unisersal serial bus (USB) analog phase-locked loop (APLL) on the C5506/C5507/C5509A devices. Example assembly programs for programming and switching to and from the APLL are also provided in the attached zip file. It is assumed that the reader is familiar with the use and operation of the C5506/C5507/C5509A USB digital phase-locked loop (DPLL) and C55x™ Digital Signal Processor (DSP) IDLE procedures.

Project collateral and source code discussed in this application report can be downloaded from the following URL: <http://www-s.ti.com/sc/techlit/spra997.zip>.

Contents

1	Introduction	2
2	The C5506/C5507/C5509A Clocking Architecture	2
3	APLL Overview	3
4	USB APLL Register (USBAPLL).....	4
5	USB PLL Selection Register (USBPLLSEL)	5
6	Switching Between the (USB DPLL/Bypass) and USB APLL	7
7	IDLING the USB PLL.....	8
8	Waking Up the USB From IDLE	9
9	Example USB PLL Programs	9
10	References	9

List of Figures

1	High-Level View of C5506/C5507/C5509A Clocking Architecture	2
2	APLL System Diagram.....	3
3	USB APLL Register (USBAPLL).....	4
4	System Clock Selection Diagram.....	5
5	USB PLL Selection Register (USBPLLSEL)	6
6	Switching to the APLL From the DPLL	7
7	Switching to the DPLL From the APLL	8

List of Tables

1	USB APLL Register (USBAPLL) Field Descriptions	4
2	M and D Values Versus MODE, DIV and MULT[3:0]	5
3	USB PLL Selection Register (USBPLLSEL) Field Descriptions	6

C55x is a trademark of Texas Instruments.
 All other trademarks are the property of their respective owners.

1 Introduction

The TMS320VC5506/C5507/C5509A USB peripherals can be clocked from either the USB APLL or the USB DPLL. Since the APLL is inherently more noise tolerant and has less long-term jitter than the DPLL, it is recommended that you switch to it for any USB operations.

2 The C5506/C5507/C5509A Clocking Architecture

The C5506/C5507/C5509A includes a DSP clock generator and a USB clock generator. Both clock generators are sourced from an input clock signal connected at the CLKIN pin. The USB clock generation circuit consists of a DPLL and an APLL; either can be enabled or disabled. The DSP clock generator circuit only contains a DPLL. [Figure 1](#) shows a high-level view of the C5506/C5507/C5509A clocking architecture. The power-up default USB clock is the bypass clock. The power-up default USB PLL is the DPLL.

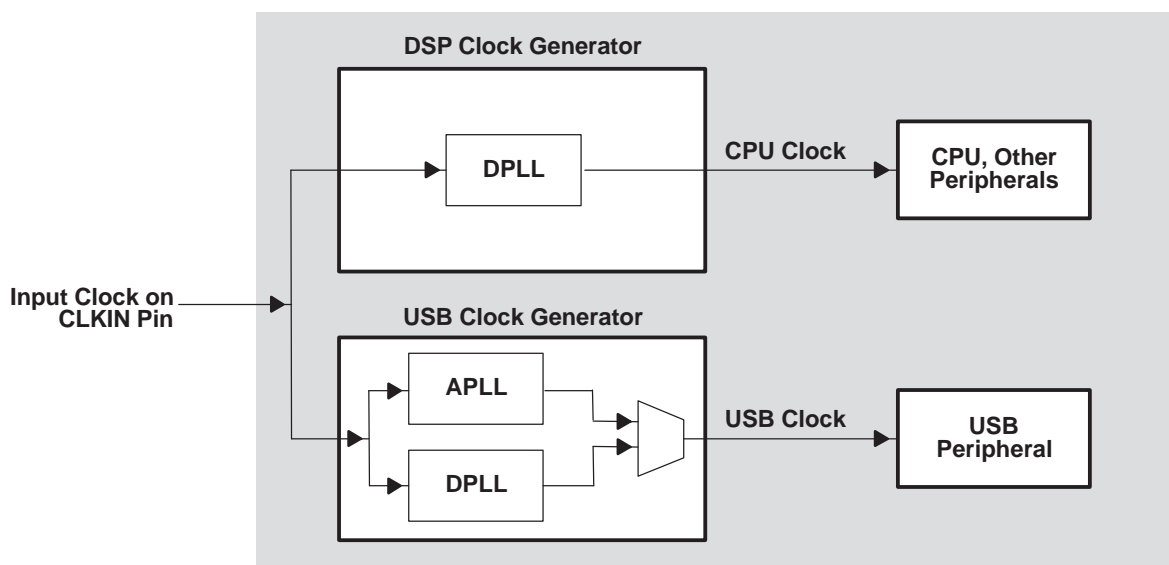
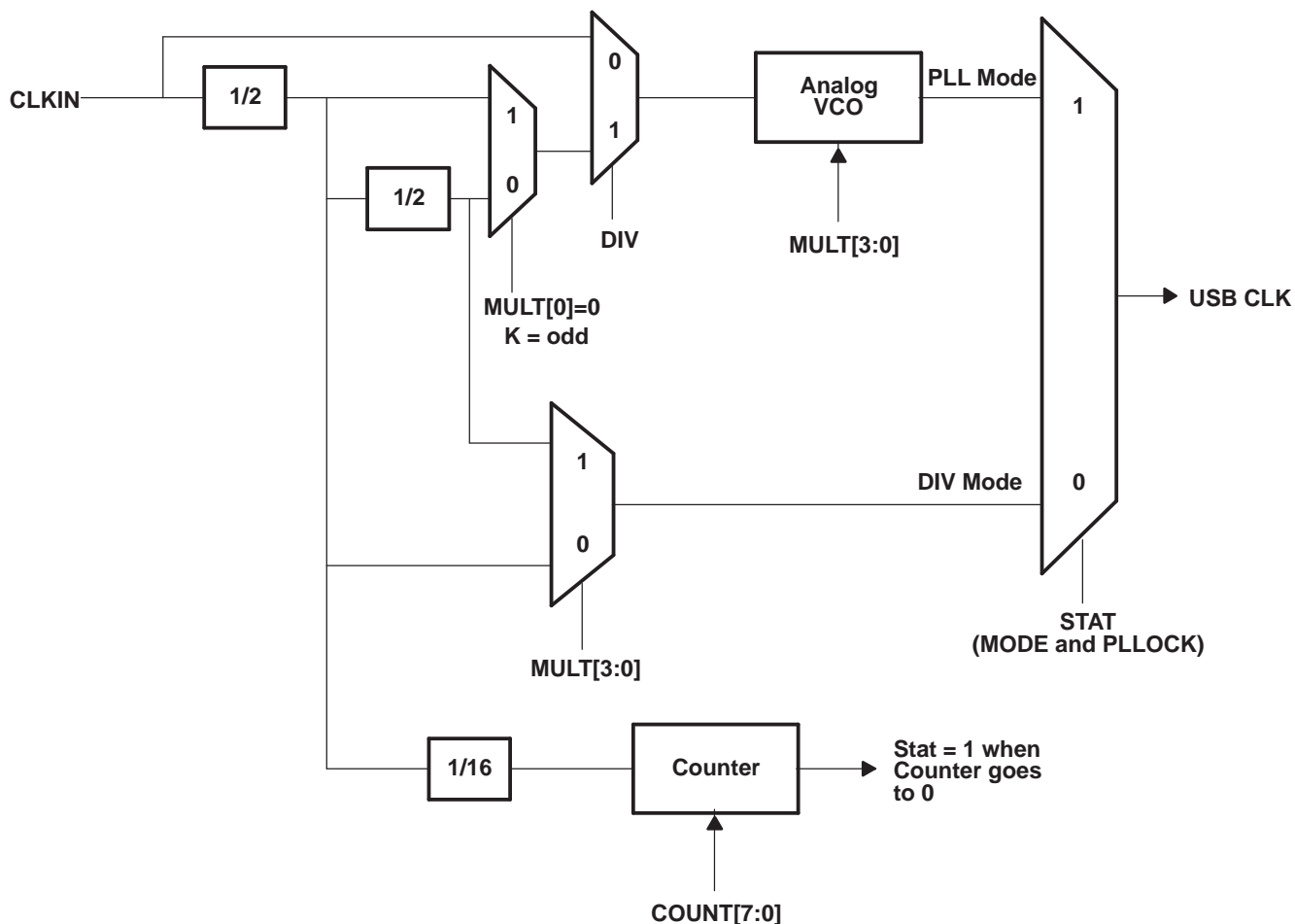

Figure 1. High-Level View of C5506/C5507/C5509A Clocking Architecture

3 APLL Overview

The purpose of the APLL is to generate the USB APLL output clock signal from the external input clock signal (CLKIN). Figure 2 shows a system diagram of the USB APLL. The APLL clock generator can be configured in one of two modes.

- DIV Mode - CLKIN/2 or CLKIN/4. The external input clock signal, CLKIN, is divided by 2 or 4.
- PLL Mode - CLKIN multiplied by one the 31 possible ratios from 0.25 to 15.



A See Table 2 for setting MULT[3:0] values. For setting APLL multiply values, see Table 1.

Figure 2. APLL System Diagram

3.1 APLL Operation in DIV Mode

The APLL is set to DIV Mode when the PLL is disabled (MODE=0 and PLLOCK=0). In DIV mode, if the K factor is set to a value other than 16 (MULT[3:0]=0xF), then the frequency of the USB APLL clock output is equal to the input clock frequency divided by 2. If the K factor is set to 16 (MULT[3:0]=0xF), then the frequency of the USB APLL clock output is equal to the input clock frequency divided by 4.

3.2 APLL Operation in PLL Mode

The APLL is set to PLL mode when the PLL is enabled (MODE=1 and PLLOCK=1). In PLL mode, the USB APLL clock output frequency is given by:

$$F_{\text{USBAPLLCLK}} = F_{\text{CLKIN}} \times (M/D)$$

where the multiplication factor is M and the dividing factor is D.

4 USB APLL Register (USBAPLL)

All the different clock modes are programmable by software by programming the USBAPLL register. The USB APLL register (USGAPLL) is located at I/O address 0x1F00 and contains the control bits as shown in [Figure 3](#) and described in [Table 1](#).

Figure 3. USB APLL Register (USBAPLL)

15	12	11	10	3	2	1	0
MULT	DIV	COUNT[7:0]			ON	MODE	STAT
R/W	R/W	R/W			R/W	R/W	R

LEGEND: R/W = Read/Write; R = Read only; -n = value after reset

Table 1. USB APLL Register (USBAPLL) Field Descriptions

Bit	Field	Value	Description																																		
15-12	MULT[3:0]		PLL multiply factor - Defines the PLL frequency multiply factor K as shown below: <table style="margin-left: 20px;"> <tr> <td>MULT[3:0]</td> <td>K</td> </tr> <tr> <td>0000</td> <td>1</td> </tr> <tr> <td>0001</td> <td>2</td> </tr> <tr> <td>0010</td> <td>3</td> </tr> <tr> <td>0011</td> <td>4</td> </tr> <tr> <td>0100</td> <td>5</td> </tr> <tr> <td>0101</td> <td>6</td> </tr> <tr> <td>0110</td> <td>7</td> </tr> <tr> <td>0111</td> <td>8</td> </tr> <tr> <td>1000</td> <td>9</td> </tr> <tr> <td>1001</td> <td>10</td> </tr> <tr> <td>1010</td> <td>11</td> </tr> <tr> <td>1011</td> <td>12</td> </tr> <tr> <td>1100</td> <td>13</td> </tr> <tr> <td>1101</td> <td>14</td> </tr> <tr> <td>1110</td> <td>15</td> </tr> <tr> <td>1111</td> <td>16</td> </tr> </table> Note: MULT[3:0] is set to a K-1	MULT[3:0]	K	0000	1	0001	2	0010	3	0011	4	0100	5	0101	6	0110	7	0111	8	1000	9	1001	10	1010	11	1011	12	1100	13	1101	14	1110	15	1111	16
MULT[3:0]	K																																				
0000	1																																				
0001	2																																				
0010	3																																				
0011	4																																				
0100	5																																				
0101	6																																				
0110	7																																				
0111	8																																				
1000	9																																				
1001	10																																				
1010	11																																				
1011	12																																				
1100	13																																				
1101	14																																				
1110	15																																				
1111	16																																				
11	DIV		PLL mode divide factor - In conjunction with multiply factor K (see Table 2), defines the PLL frequency divide factor D.																																		
10-3	COUNT[7:0]		PLL lock count - A counter that starts decrementing from its preset values as soon as MODE is set to HIGH.																																		
2	ON		PLL on - Enables the APLL internal VCO. Both ON or MODE force operation of the PLL VCO. <table style="margin-left: 20px;"> <tr> <td>ON</td> <td>MODE</td> <td>Analog VCO</td> </tr> <tr> <td>0</td> <td>0</td> <td>OFF</td> </tr> <tr> <td>1</td> <td>0</td> <td>ON</td> </tr> <tr> <td>0</td> <td>1</td> <td>ON</td> </tr> <tr> <td>1</td> <td>1</td> <td>ON</td> </tr> </table>	ON	MODE	Analog VCO	0	0	OFF	1	0	ON	0	1	ON	1	1	ON																			
ON	MODE	Analog VCO																																			
0	0	OFF																																			
1	0	ON																																			
0	1	ON																																			
1	1	ON																																			
1	MODE		PLL mode/Not DIV mode - Sets the clock generator mode to PLL when HIGH and to divider (Div) when LOW.																																		
0	STAT	0 1	PLL lock status - Indicates the mode of the APLL clock generator. 0 DIV mode, the system clock is the input clock divided by 2 or 4 1 PLL mode, the system clock is the input clock multiplied by the PLL multiplication ratio.																																		

DIV, combined with MODE and K, defines the PLL multiplication ratio M/D as indicated below. The USB APLL clock frequency is then given by:

$$F_{\text{USBAPCLK}} = F_{\text{CLKIN}} \times (M/D)$$

The multiplication factor M and the dividing factor D are defined in [Table 2](#).

Table 2. M and D Values Versus MODE, DIV and MULT[3:0]

MODE	DIV	K	M	D
0	x	1 to 15	1	2
0	x	16	1	4
1	1	1 to 15	K	1
1	1	16	1	1
1	4	odd	K	2
1	4	even	K-1	4

Since the APLL uses an analog VCO, the APLL requires a lockup time before it is stable. Normally, during lock up time, the APLL-clock mode cannot be used and it must be in DIV mode. In DIV mode MODE is set to 0.

A programmable timer COUNT is included in the APLL peripheral to use as a time keeper for PLL locking. This timer is a counter USBAPLL[10:3] which decrements from a preset value to zero. At zero, it sets the STAT bit USBAPLL[0] to 1. The time can be preset from 0 up to 255 and its input clock is CLKIN divided by 16. So, the corresponding lockup time can be set from 0x16 to 256x16 CLKIN cycles. The COUNT is located at USBAPLL[10:3] and is programmed using the following equation:

$$\text{PLCOUNT} = \frac{\text{LockTime}}{(16 \times T_{\text{CLKIN}})}$$

where T_{CLKIN} is the input reference clock period and $\text{LockTime} = 30 \mu\text{s}$.

5 USB PLL Selection Register (USBPLLSEL)

The DSP includes a USB PLL selection register (USBPLLSEL) that allows for switching between the APLL and DPLL, and allows for monitoring of the PLL status. A functional diagram of the USBPLLSEL register is shown in [Figure 4](#).

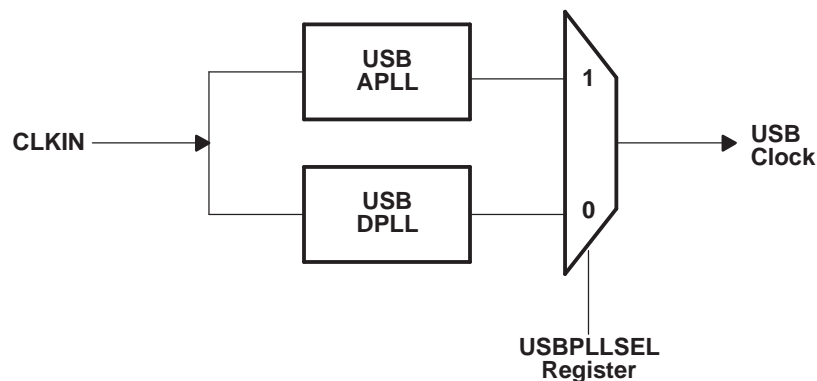
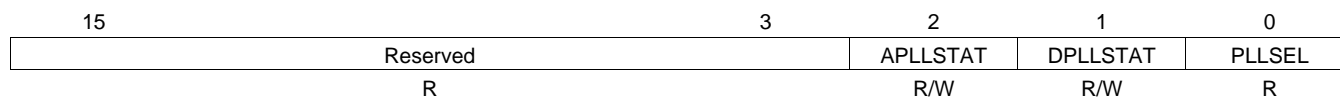

Figure 4. System Clock Selection Diagram

The USBPLLSEL register is located at I/O space address 0x1E80 and has the fields shown in [Figure 5](#) and described in [Table 3](#).

Figure 5. USB PLL Selection Register (USBPLLSEL)



LEGEND: R/W = Read/Write; R = Read only; -n = value after reset

Table 3. USB PLL Selection Register (USBPLLSEL) Field Descriptions

Bit	Field	Value	Description
15-3	Reserved	0	Reserved
2	APLLSTAT	0	If set to 0, the APLL is providing the clock to the USB peripheral
		1	If set to 1, the APLL is not providing the clock to the USB peripheral.
1	DPLLSTAT	0	If set to 0, the DPLL is providing the clock to the USB peripheral.
		1	If set to 1, the DPLL is not providing the clock to the USB peripheral.
0	PLLSEL	0	If set to 0, the DPLL is providing the clock to the USB peripheral.
		1	If set to 1, the APLL is providing the clock to the USB peripheral.

6 Switching Between the (USB DPLL/Bypass) and USB APLL

6.1 Switching to the APLL From the DPLL

Switching to the APLL from either the DPLL or the bypass clock is done by first enabling and setting up the APLL, while the system is being driven by the DPLL or bypass clock, then switching to the APLL. The flowchart shown in Figure 6 outlines this process, assuming that the system is operating with either the DPLL or bypass clock.

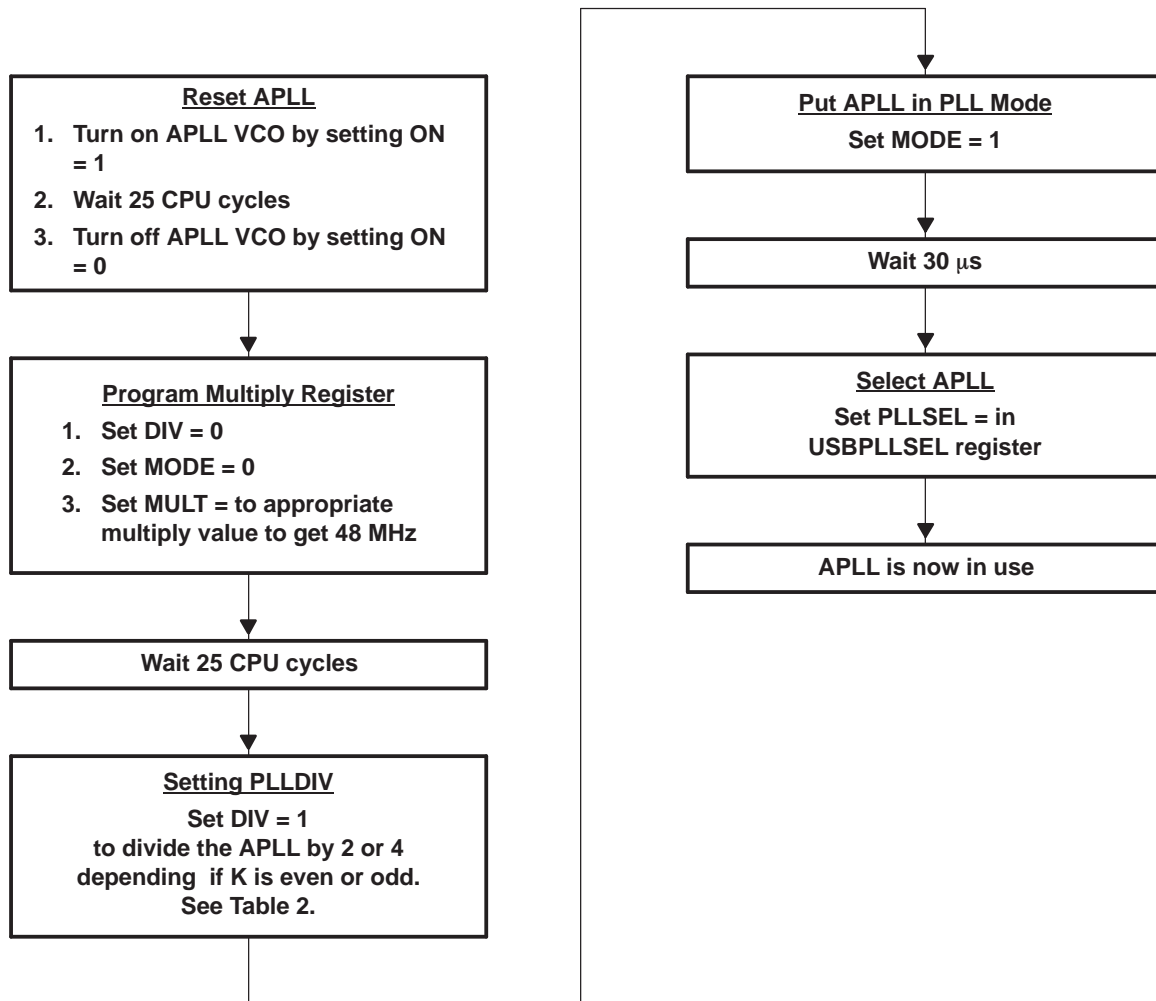

Figure 6. Switching to the APLL From the DPLL

6.2 Switching to the DPLL From the APLL

The procedure shown in [Figure 7](#) outlines switching from APLL mode back to DPLL mode, assuming that the system is operating with APLL.

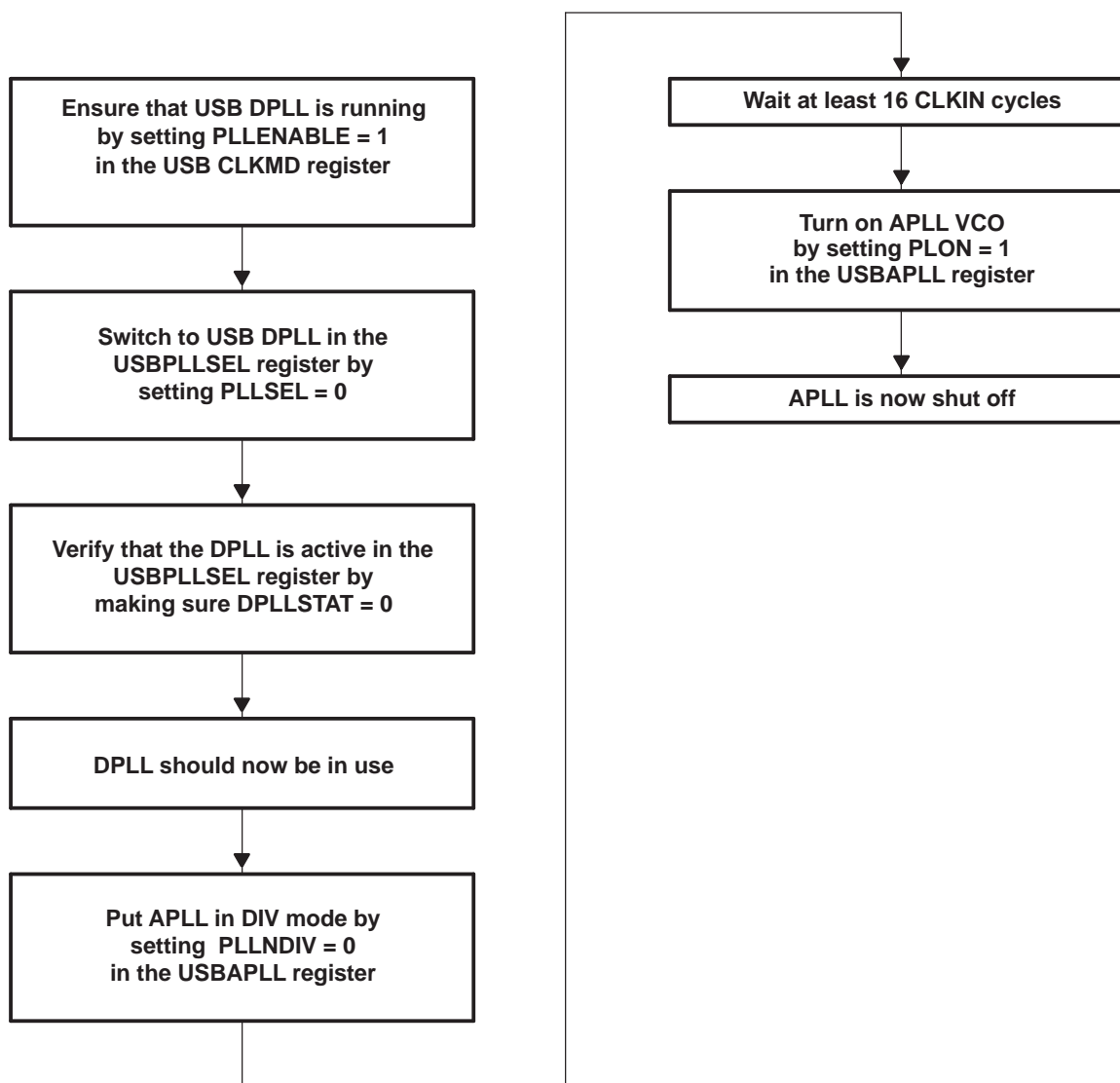

Figure 7. Switching to the DPLL From the APLL

7 IDLING the USB PLL

To IDLE the USB APLL, first switch to the USB DPLL and then shut off the APLL; then IDLE the clock generation domain. The following procedure outlines this process.

Assuming that the APLL is in operation, follow these steps:

1. Switch to the DPLL as described in [Section 6.2](#).
2. Double check that the APLL VCO is off, by checking the ON bit.
3. IDLE the clock generation domain using the ICR and IDLE instruction.

8 Waking Up the USB From IDLE

Since the DPLL is used to get into IDLE, waking up from IDLE uses the DPLL wake-up criteria. For details, see *Disabling the Internal Oscillator on the TMS320VC5503/C5506/C5507/C5509/C5509A DSP* ([SPRA078](#)). After waking up from IDLE, follow [Section 6.1](#) to reinitialize the APLL. The following procedure outlines this process:

- Wake-up event awakens the CPU
- CPU is in DPLL or bypass mode
- Switch to the APLL as described in [Section 6.1](#)

9 Example USB PLL Programs

Included in this application report are two example assembly programs which demonstrate some of the topics covered in this application note. It is highly recommended that you study and run these examples to get a clearer understanding of the USB APLL.

- DPLL_To_APLL - switches from the power on default of DPLL/Bypass to the APLL.
- APLL_To_DPLL - switches the APLL back to the DPLL and then shuts off the APLL.

10 References

- *Disabling the Internal Oscillator on the TMS320VC5503/C5506/C5507/C5509/C5509A DSP* ([SPRA078](#))

IMPORTANT NOTICE

Texas Instruments Incorporated and its subsidiaries (TI) reserve the right to make corrections, modifications, enhancements, improvements, and other changes to its products and services at any time and to discontinue any product or service without notice. Customers should obtain the latest relevant information before placing orders and should verify that such information is current and complete. All products are sold subject to TI's terms and conditions of sale supplied at the time of order acknowledgment.

TI warrants performance of its hardware products to the specifications applicable at the time of sale in accordance with TI's standard warranty. Testing and other quality control techniques are used to the extent TI deems necessary to support this warranty. Except where mandated by government requirements, testing of all parameters of each product is not necessarily performed.

TI assumes no liability for applications assistance or customer product design. Customers are responsible for their products and applications using TI components. To minimize the risks associated with customer products and applications, customers should provide adequate design and operating safeguards.

TI does not warrant or represent that any license, either express or implied, is granted under any TI patent right, copyright, mask work right, or other TI intellectual property right relating to any combination, machine, or process in which TI products or services are used. Information published by TI regarding third-party products or services does not constitute a license from TI to use such products or services or a warranty or endorsement thereof. Use of such information may require a license from a third party under the patents or other intellectual property of the third party, or a license from TI under the patents or other intellectual property of TI.

Reproduction of TI information in TI data books or data sheets is permissible only if reproduction is without alteration and is accompanied by all associated warranties, conditions, limitations, and notices. Reproduction of this information with alteration is an unfair and deceptive business practice. TI is not responsible or liable for such altered documentation. Information of third parties may be subject to additional restrictions.

Resale of TI products or services with statements different from or beyond the parameters stated by TI for that product or service voids all express and any implied warranties for the associated TI product or service and is an unfair and deceptive business practice. TI is not responsible or liable for any such statements.

TI products are not authorized for use in safety-critical applications (such as life support) where a failure of the TI product would reasonably be expected to cause severe personal injury or death, unless officers of the parties have executed an agreement specifically governing such use. Buyers represent that they have all necessary expertise in the safety and regulatory ramifications of their applications, and acknowledge and agree that they are solely responsible for all legal, regulatory and safety-related requirements concerning their products and any use of TI products in such safety-critical applications, notwithstanding any applications-related information or support that may be provided by TI. Further, Buyers must fully indemnify TI and its representatives against any damages arising out of the use of TI products in such safety-critical applications.

TI products are neither designed nor intended for use in military/aerospace applications or environments unless the TI products are specifically designated by TI as military-grade or "enhanced plastic." Only products designated by TI as military-grade meet military specifications. Buyers acknowledge and agree that any such use of TI products which TI has not designated as military-grade is solely at the Buyer's risk, and that they are solely responsible for compliance with all legal and regulatory requirements in connection with such use.

TI products are neither designed nor intended for use in automotive applications or environments unless the specific TI products are designated by TI as compliant with ISO/TS 16949 requirements. Buyers acknowledge and agree that, if they use any non-designated products in automotive applications, TI will not be responsible for any failure to meet such requirements.

Following are URLs where you can obtain information on other Texas Instruments products and application solutions:

Products

Amplifiers	amplifier.ti.com
Data Converters	dataconverter.ti.com
DSP	dsp.ti.com
Clocks and Timers	www.ti.com/clocks
Interface	interface.ti.com
Logic	logic.ti.com
Power Mgmt	power.ti.com
Microcontrollers	microcontroller.ti.com
RFID	www.ti-rfid.com
RF/IF and ZigBee® Solutions	www.ti.com/lprf

Applications

Audio	www.ti.com/audio
Automotive	www.ti.com/automotive
Broadband	www.ti.com/broadband
Digital Control	www.ti.com/digitalcontrol
Medical	www.ti.com/medical
Military	www.ti.com/military
Optical Networking	www.ti.com/opticalnetwork
Security	www.ti.com/security
Telephony	www.ti.com/telephony
Video & Imaging	www.ti.com/video
Wireless	www.ti.com/wireless

Mailing Address: Texas Instruments, Post Office Box 655303, Dallas, Texas 75265
Copyright © 2008, Texas Instruments Incorporated