

SBS 1.1-COMPLIANT GAS GAUGE ENABLED WITH IMPEDANCE TRACK™ TECHNOLOGY FOR USE WITH THE bq29330

FEATURES

- **Next Generation Patented Impedance Track™ Technology Accurately Measures Available Charge in Li-Ion and Li-Polymer Batteries**
 - Better Than 1% Error Over the Lifetime of the Battery
- **Supports the Smart Battery Specification SBS V1.1**
- **Flexible Configuration for 2 to 4 Series Li-Ion and Li-Polymer Cells**
- **Powerful 8-Bit RISC CPU With Ultralow Power Modes**
- **Full Array of Programmable Protection Features**
 - Voltage, Current, and Temperature
- **Satisfies JEITA Guidelines**
- **Added Flexibility to Handle More Complex Charging Profiles**
- **Lifetime Data Logging**
- **Supports SHA-1 Authentication**
- **Available in a 20-Pin TSSOP (PW) package**

DESCRIPTION

The bq20z40 SBS-compliant gas gauge and protection IC, incorporating patented Impedance Track™ technology, is designed for battery-pack or in-system installation. The bq20z40 measures and maintains an accurate record of available charge in Li-ion or Li-polymer batteries using its integrated high-performance analog peripherals. The bq20z40 monitors capacity change, battery impedance, open-circuit voltage, and other critical parameters of the battery pack, and reports the information to the system host controller over a serial-communication bus. It is designed to work with the bq29330 analog front-end (AFE) protection IC to maximize functionality and safety while minimizing external component count and cost in smart battery circuits.

The Impedance Track™ technology continuously analyzes the battery impedance, resulting in superior gas-gauging accuracy. This enables the remaining capacity to be calculated with discharge rate, temperature, and cell aging that are all accounted for during each stage of every cycle.

APPLICATIONS

- **Notebook PCs**
- **Medical and Test Equipment**
- **Portable Instrumentation**

AVAILABLE OPTIONS

T _A	PACKAGE	
	20-PIN TSSOP (PW) Tube	20-PIN TSSOP (PW) Tape & Reel
–40°C to 85°C	bq20z40PW ⁽¹⁾	bq20z40PWR ⁽²⁾

- (1) A single tube quantity is 50 units.
(2) A single reel quantity is 2000 units



Please be aware that an important notice concerning availability, standard warranty, and use in critical applications of Texas Instruments semiconductor products and disclaimers thereto appears at the end of this data sheet.

Impedance Track is a trademark of Texas Instruments.

bq20z40

SLUS801A—FEBRUARY 2009—REVISED MARCH 2009

www.ti.com



These devices have limited built-in ESD protection. The leads should be shorted together or the device placed in conductive foam during storage or handling to prevent electrostatic damage to the MOS gates.

SYSTEM PARTITIONING DIAGRAM

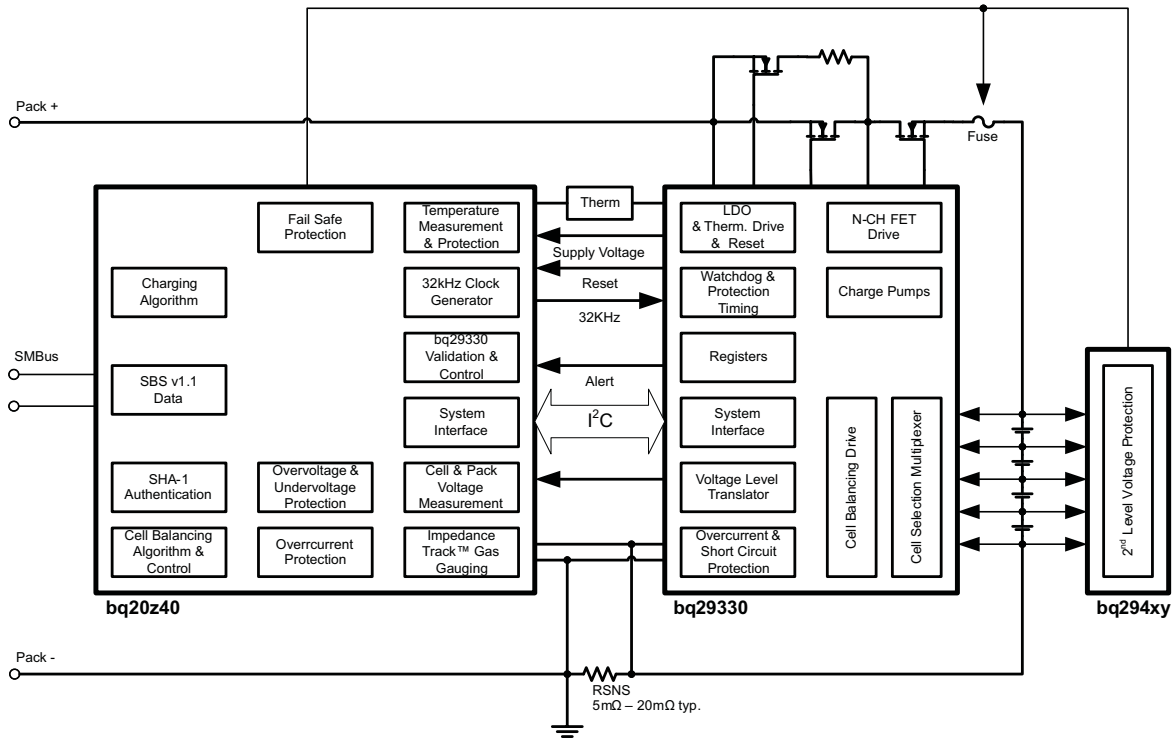
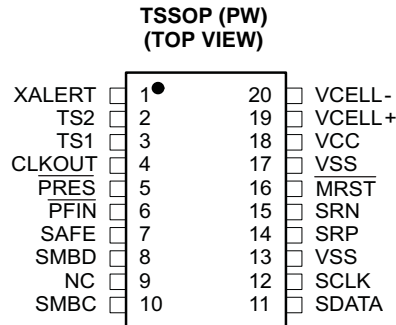

Figure 1.



PIN FUNCTIONS

PIN		I/O ⁽¹⁾	DESCRIPTION
NO.	NAME		
1	XALERT	I	Input from bq29330 XALERT output.
2	TS2	I	2 nd Thermistor voltage input connection to monitor temperature
3	TS1	I	1 st Thermistor voltage input connection to monitor temperature
4	CLKOUT	O	32.768-kHz output for the bq29330. This pin should be directly connected to the AFE.
5	PRES	I	Active low input to sense system insertion. Typically requires additional ESD protection.
6	PFIN	I	Active low input to detect secondary protector output status, and to allow the bq20z40 to report the status of the 2 nd level protection output
7	SAFE	O	Active high output to enforce additional level of safety protection; e.g., fuse blow.
8	SMBD	I/OD	SMBus data open-drain bidirectional pin used to transfer address and data to and from the bq20z40
9	NC	–	Not used— leave floating
10	SMBC	I/OD	SMBus clock open-drain bidirectional pin used to clock the data transfer to and from the bq20z40
11	SDATA	I/O	Data transfer to and from bq29330
12	SCLK	I/O	Communication clock to the bq29330
13	VSS	–	Connected I/O pin to VSS
14	SRP	IA	Connections for a small-value sense resistor to monitor the battery charge- and discharge-current flow
15	SRN	IA	Connections for a small-value sense resistor to monitor the battery charge- and discharge-current flow
16	MRST	I	Master reset input that forces the device into reset when held low. Must be held high for normal operation
17	VSS	P	Negative Supply Voltage
18	VCC	P	Positive Supply Voltage
19	VCELL+	I	Input from bq29330 used to read a scaled value of individual cell voltages
20	VCELL–	I	Input from bq29330 used to read a scaled value of individual cell voltages

(1) I = Input, IA = Analog input, I/O = Input/output, I/OD = Input/Open-drain output, O = Output, OA = Analog output, P = Power

ABSOLUTE MAXIMUM RATINGS

 over operating free-air temperature range (unless otherwise noted)⁽¹⁾

		RANGE
V _{CC} relative to V _{SS}	Supply voltage range	−0.3 V to 2.75 V
V _(IOD) relative to V _{SS}	Open-drain I/O pins	−0.3 V to 6 V
V _I relative to V _{SS}	Input voltage range to all other pins	−0.3 V to V _{CC} + 0.3 V
T _A	Operating free-air temperature range	−40°C to 85°C
T _{stg}	Storage temperature range	−65°C to 150°C

(1) Stresses beyond those listed under absolute maximum ratings may cause permanent damage to the device. These are stress ratings only, and functional operation of the device at these or any other conditions beyond those indicated under recommended operating conditions is not implied. Exposure to absolute-maximum-rated conditions for extended periods may affect device reliability.

ELECTRICAL CHARACTERISTICS

 V_{CC} = 2.4 V to 2.6 V, T_A = −40°C to 85°C (unless otherwise noted)

PARAMETER		TEST CONDITIONS	MIN	TYP	MAX	UNIT
V _{CC}	Supply voltage		2.4	2.5	2.6	V
I _{CC}	Operating mode current	No flash programming		400 ⁽¹⁾		μA
		bq20z40 + bq29330		475		
I _(SLP)	Low-power storage mode current	Sleep mode		8 ⁽¹⁾		μA
		bq20z40 + bq29330		51		
I _(SD)	Shutdown Mode Current	Shutdown mode		0.1 ⁽¹⁾		μA
		bq20z40 + bq29330		0.2		
V _{OL}	Output voltage low SMBC, SMBD, SDATA, SCLK, SAFE	I _{OL} = 0.5 mA			0.4	V
V _{OH}	Output high voltage, SMBC, SMBD, SDATA, SCLK, SAFE	I _{OH} = −1 mA	V _{CC} − 0.5			V
V _{IL}	Input voltage low SMBC, SMBD, SDATA, SCLK, XALERT, PRES, PFIN		−0.3		0.8	V
V _{IH}	Input voltage high SMBC, SMBD, SDATA, SCLK, XALERT, PRES, PFIN		2		6	V
C _{IN}	Input capacitance			5		pF
V _(AI1)	Input voltage range VCELL+, VCELL-, TS1, TS2		−0.2		0.8xV _{CC}	V
V _(AI2)	Input voltage range SRN, SRP		−0.20		0.20	V
Z _(AI2)	Input impedance VCELL+, VCELL-, TS1, TS2	0 V–1 V		8		MΩ
Z _(AI1)	Input impedance SRN, SRP	0 V–1 V		2.5		MΩ

(1) This value does not include the bq29330

POWER-ON RESET

 V_{CC} = 2.4V to 2.6 V, T_A = −40°C to 85°C (unless otherwise noted)

PARAMETER		TEST CONDITIONS	MIN	TYP	MAX	UNIT
V _{IT−}	Negative-going voltage input		1.7	1.8	1.9	V
V _{HYS}	Power-on reset hysteresis		50	125	200	mV

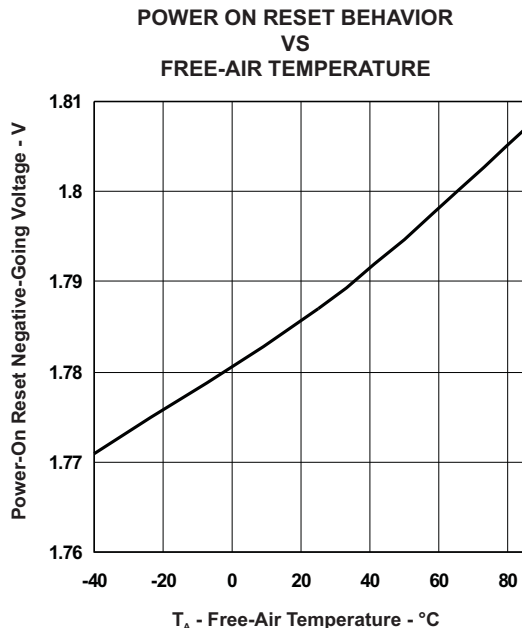

INTEGRATING ADC (Coulomb Counter) CHARACTERISTICS

V_{CC} = 2.4V to 2.6 V, T_A = -40°C to 85°C (unless otherwise noted)

PARAMETER	TEST CONDITIONS	MIN	TYP	MAX	UNIT
V _(SR) Input voltage range, V _(SRN) and V _(SRP)	V _(SR) = V _(SRN) – V _(SRP)	-0.2		0.2	V
V _(SROS) Input offset			10		μV
INL Integral nonlinearity error			0.007%	0.034%	

OSCILLATOR

V_{CC} = 2.4 V to 2.6 V, T_A = -40°C to 85°C (unless otherwise noted)

PARAMETER	TEST CONDITIONS	MIN	TYP	MAX	UNIT
HIGH FREQUENCY OSCILLATOR					
f _(OSC) Operating Frequency				4.194	MHz
f _(EIO) Frequency Error ⁽¹⁾⁽²⁾		-3%	0.25%	3%	
	T _A = 20°C to 70°C	-2%	0.25%	2%	
t _(SXO) Start-up Time ⁽³⁾			2.5	5	ms
LOW FREQUENCY OSCILLATOR					
f _(LOSC) Operating Frequency			32.768		KHz
f _(LEIO) Frequency Error ⁽²⁾⁽⁴⁾		-2.5%	0.25%	2.5%	
	T _A = 20°C to 70°C	-1.5%	0.25%	1.5%	
t _(LSXO) Start-up time ⁽⁵⁾				500	μs

- (1) The frequency error is measured from 4.194 MHz.
- (2) The frequency drift is included and measured from the trimmed frequency at V_{CC} = 2.5 V, T_A = 25°C.
- (3) The start-up time is defined as the time it takes for the oscillator output frequency to be within 1 % of the specified frequency.
- (4) The frequency error is measured from 32.768 kHz.
- (5) The start-up time is defined as the time it takes for the oscillator output frequency to be ± 3%.

DATA FLASH MEMORY CHARACTERISTICS

 $V_{CC} = 2.4\text{ V to }2.6\text{ V}$, $T_A = -40^\circ\text{C to }85^\circ\text{C}$ (unless otherwise noted)

PARAMETER		TEST CONDITIONS	MIN	TYP	MAX	UNIT
t_{DR}	Data retention	See ⁽¹⁾	10			Years
	Flash programming write-cycles	See ⁽¹⁾	20,000			Cycles
$t_{(WORDPROG)}$	Word programming time	See ⁽¹⁾			2	ms
$I_{(DDdPROG)}$	Flash-write supply current	See ⁽¹⁾		5	10	mA

(1) Specified by design. Not production tested.

SMBus TIMING SPECIFICATIONS

 $V_{CC} = 2.4\text{ V to }2.6\text{ V}$, $T_A = -40^\circ\text{C to }85^\circ\text{C}$ (unless otherwise noted)

PARAMETER		TEST CONDITIONS	MIN	TYP	MAX	UNIT
f_{SMB}	SMBus operating frequency	Slave mode, SMBC 50% duty cycle	10		100	kHz
f_{MAS}	SMBus master clock frequency	Master mode, no clock low slave extend		51.2		
t_{BUF}	Bus free time between start and stop		4.7			μs
$t_{HD:STA}$	Hold time after (repeated) start		4			
$t_{SU:STA}$	Repeated start setup time		4.7			
$t_{SU:STO}$	Stop setup time		4			
$t_{HD:DAT}$	Data hold time	Receive mode	0			ns
		Transmit mode	300			
$t_{SU:DAT}$	Data setup time		250			
$t_{TIMEOUT}$	Error signal/detect	See ⁽¹⁾	25		35	ms
t_{LOW}	Clock low period		4.7			μs
t_{HIGH}	Clock high period	See ⁽²⁾	4		50	
$t_{LOW:SEXT}$	Cumulative clock low slave extend time	See ⁽³⁾			25	ms
$t_{LOW:MEXT}$	Cumulative clock low master extend time	See ⁽⁴⁾			10	
t_F	Clock/data fall time	$(V_{ILMAX} - 0.15\text{ V})$ to $(V_{IHMIN} + 0.15\text{ V})$			300	ns
t_R	Clock/data rise time	$0.9 V_{CC}$ to $(V_{ILMAX} - 0.15\text{ V})$			1000	

(1) The bq20z40 times out when any clock low exceeds $t_{TIMEOUT}$.

(2) $t_{HIGH:MAX}$ is minimum bus idle time. SMBC = 1 for $t > 50\ \mu\text{s}$ causes reset of any transaction involving the bq20z40 that is in progress.

(3) $t_{LOW:SEXT}$ is the cumulative time a slave device is allowed to extend the clock cycles in one message from initial start to the stop.

(4) $t_{LOW:MEXT}$ is the cumulative time a master device is allowed to extend the clock cycles in one message from initial start to the stop.

FEATURE SET

Primary (1st Level) Safety Features

The bq20z40 supports a wide range of battery and system protection features that can easily be configured. The primary safety features include:

- Cell over/undervoltage protection
- Charge and discharge overcurrent
- Short Circuit
- Charge and discharge overtemperature with independent alarms and thresholds for each thermistor
- AFE Watchdog

Secondary (2nd Level) Safety Features

The secondary safety features of the bq20z40 can be used to indicate more serious faults via the SAFE (pin 7). This pin can be used to blow an in-line fuse to permanently disable the battery pack from charging or discharging. The secondary safety protection features include:

- Safety overvoltage
- Safety undervoltage
- Safety overcurrent in charge and discharge
- Safety overtemperature in charge and discharge with independent alarms and thresholds for each thermistor
- Charge FET and 0 Volt Charge FET fault
- Discharge FET fault
- Cell imbalance detection (active and at rest)
- Open thermistor detection
- AFE communication fault

Charge Control Features

The bq20z40 charge control features include:

- Supports JEITA temperature ranges. Reports charging voltage and charging current according to the active temperature range.
- Handles more complex charging profiles. Allows for splitting the standard temperature range into 2 sub-ranges and allows for varying the charging current according to the cell voltage.
- Reports the appropriate charging current needed for constant current charging and the appropriate charging voltage needed for constant voltage charging to a smart charger using SMBus broadcasts.
- Determines the chemical state of charge of each battery cell using Impedance Track™ and can reduce the charge difference of the battery cells in fully charged state of the battery pack gradually using cell balancing algorithm during charging. This prevents fully charged cells from overcharging and causing excessive degradation and also increases the usable pack energy by preventing premature charge termination
- Supports pre-charging/zero-volt charging
- Supports charge inhibit and charge suspend if battery pack temperature is out of temperature range
- Reports charging fault and also indicate charge status via charge and discharge alarms.

Gas Gauging

The bq20z40 uses the Impedance Track™ Technology to measure and calculate the available charge in battery cells. The achievable accuracy is better than 1% error over the lifetime of the battery and there is no full charge discharge learning cycle required.

See *Theory and Implementation of Impedance Track Battery Fuel-Gauging Algorithm* application note ([SLUA364](#)) for further details.

Lifetime Data Logging Features

The bq20z40 offers lifetime data logging, where important measurements are stored for warranty and analysis purposes. The data monitored include:

- Lifetime maximum temperature
- Lifetime minimum temperature
- Lifetime maximum battery cell voltage
- Lifetime minimum battery cell voltage
- Lifetime maximum battery pack voltage
- Lifetime minimum battery pack voltage
- Lifetime maximum charge current
- Lifetime maximum discharge current
- Lifetime maximum charge power
- Lifetime maximum discharge power
- Lifetime maximum average discharge current
- Lifetime maximum average discharge power
- Lifetime average temperature

Authentication

The bq20z40 supports authentication by the host using SHA-1.

Power Modes

The bq20z40 supports 3 different power modes to reduce power consumption:

- In Normal Mode, the bq20z40 performs measurements, calculations, protection decisions and data updates in 1 second intervals. Between these intervals, the bq20z40 is in a reduced power stage.
- In Sleep Mode, the bq20z40 performs measurements, calculations, protection decisions and data update in adjustable time intervals. Between these intervals, the bq20z40 is in a reduced power stage. The bq20z40 has a wake function that enables exit from Sleep mode, when current flow or failure is detected.
- In Shutdown Mode the bq20z40 is completely disabled.

CONFIGURATION

Oscillator Function

The bq20z40 fully integrates the system and processor oscillators and, therefore, requires no pins or components for this feature.

System Present Operation

The bq20z40 periodically verifies the $\overline{\text{PRES}}$ pin and detects that the battery is present in the system via a low state on a $\overline{\text{PRES}}$ input. When this occurs, bq20z40 enters normal operating mode. When the pack is removed from the system and the $\overline{\text{PRES}}$ input is high, the bq20z40 enters the battery-removed state, disabling the charge, discharge and ZVCHG FETs. The $\overline{\text{PRES}}$ input is ignored and can be left floating when non-removal mode is set in the data flash.

BATTERY PARAMETER MEASUREMENTS

The bq20z40 uses an integrating delta-sigma analog-to-digital converter (ADC) for current measurement, and a second delta-sigma ADC for individual cell and battery voltage, and temperature measurement.

bq20z40

SLUS801A—FEBRUARY 2009—REVISED MARCH 2009

www.ti.com

Charge and Discharge Counting

The integrating delta-sigma ADC measures the charge/discharge flow of the battery by measuring the voltage drop across a small-value sense resistor between the SRP and SRN pins. The integrating ADC measures bipolar signals from -0.25 V to 0.25 V. The bq20z40 detects charge activity when $V_{SR} = V_{(SRP)} - V_{(SRN)}$ is positive, and discharge activity when $V_{SR} = V_{(SRP)} - V_{(SRN)}$ is negative. The bq20z40 continuously integrates the signal over time, using an internal counter. The fundamental rate of the counter is 0.65 nVh.

Voltage

The bq20z40 updates the individual series cell voltages through the bq29330 at one second intervals. The bq20z40 configures the bq29330 to connect the selected cell, cell offset, or bq29330 VREF to the CELL pin of the bq29330, which is required to be connected to VIN of the bq20z40. The internal ADC of the bq20z40 measures the voltage, scales it, and calibrates itself appropriately. This data is also used to calculate the impedance of the cell for the Impedance Track™ gas-gauging.

Current

The bq20z40 uses the SRP and SRN inputs to measure and calculate the battery charge and discharge current using a 5 mΩ to 20 mΩ typ. sense resistor.

Wake Function

The bq20z40 can exit sleep mode, if enabled, by the presence of a programmable level of current signal across SRP and SRN.

Auto Calibration

The bq20z40 provides an auto-calibration feature to cancel the voltage offset error across SRP and SRN for maximum charge measurement accuracy. The bq20z40 performs auto-calibration when the SMBus lines stay low continuously for a minimum of a programmable amount of time.

Temperature

The bq20z40 has an internal temperature sensor and inputs for 2 external temperature sensors, TS1 and TS2, used in conjunction with two identical NTC thermistors (default are Semitec 103AT) to sense the battery environmental temperature. The bq20z40 can be configured to use internal, or up to 2 external temperature sensors.

COMMUNICATIONS

The bq20z40 uses SMBus v1.1 with Master Mode and package error checking (PEC) options per the SBS specification.

SMBus On and Off State

The bq20z40 detects an SMBus off state when SMBC and SMBD are logic-low for ≥ 2 seconds. Clearing this state requires either SMBC or SMBD to transition high. Within 1 ms, the communication bus is available.

SBS Commands

Table 1. SBS COMMANDS

SBS Cmd	Mode	Name	Format	Size in Bytes	Min Value	Max Value	Default Value	Unit
0x00	R/W	ManufacturerAccess	hex	2	0x0000	0xffff	—	
0x01	R/W	RemainingCapacityAlarm	unsigned int	2	0	65535	300	mAh or 10mWh
0x02	R/W	RemainingTimeAlarm	unsigned int	2	0	65535	10	min
0x03	R/W	BatteryMode	hex	2	0x0000	0xe383	—	
0x04	R/W	AtRate	signed int	2	-32768	32767	—	mA or 10mW
0x05	R	AtRateTimeToFull	unsigned int	2	0	65534	—	min
0x06	R	AtRateTimeToEmpty	unsigned int	2	0	65534	—	min
0x07	R	AtRateOK	unsigned int	2	0	65535	—	
0x08	R	Temperature	unsigned int	2	0	65535	—	0.1°K
0x09	R	Voltage	unsigned int	2	0	65535	—	mV
0x0a	R	Current	signed int	2	-32768	32767	—	mA
0x0b	R	AverageCurrent	signed int	2	-32768	32767	—	mA
0x0c	R	MaxError	unsigned int	1	0	100	—	%
0x0d	R	RelativeStateOfCharge	unsigned int	1	0	100	—	%
0x0e	R	AbsoluteStateOfCharge	unsigned int	1	0	100+	—	%
0x0f	R/W	RemainingCapacity	unsigned int	2	0	65535	—	mAh or 10mWh
0x10	R	FullChargeCapacity	unsigned int	2	0	65535	—	mAh or 10mWh
0x11	R	RunTimeToEmpty	unsigned int	2	0	65534	—	min
0x12	R	AverageTimeToEmpty	unsigned int	2	0	65534	—	min
0x13	R	AverageTimeToFull	unsigned int	2	0	65534	—	min
0x14	R	ChargingCurrent	unsigned int	2	0	65534	—	mA
0x15	R	ChargingVoltage	unsigned int	2	0	65534	—	mV
0x16	R	BatteryStatus	hex	2	0x0000	0xdbff	—	
0x17	R/W	CycleCount	unsigned int	2	0	65535	—	
0x18	R/W	DesignCapacity	unsigned int	2	0	65535	4400	mAh or 10mWh
0x19	R/W	DesignVoltage	unsigned int	2	0	65535	14400	mV
0x1a	R/W	SpecificationInfo	hex	2	0x0000	0xffff	0x0031	
0x1b	R/W	ManufactureDate	unsigned int	2	—	—	01-Jan-1980	—
0x1c	R/W	SerialNumber	hex	2	0x0000	0xffff	0x0001	
0x20	R/W	ManufacturerName	String	20+1	—	—	Texas Inst.	—
0x21	R/W	DeviceName	String	20+1	—	—	bq20z40	—
0x22	R/W	DeviceChemistry	String	4+1	—	—	LION	—
0x23	R/W	ManufacturerData	String	14+1	—	—	—	—
0x2f	R/W	Authenticate	String	20+1	—	—	—	—
0x3c	R	CellVoltage4	unsigned int	2	0	65535	—	mV
0x3d	R	CellVoltage3	unsigned int	2	0	65535	—	mV
0x3e	R	CellVoltage2	unsigned int	2	0	65535	—	mV
0x3f	R	CellVoltage1	unsigned int	2	0	65535	—	mV

Table 2. EXTENDED SBS COMMANDS

SBS Cmd	Mode	Name	Format	Size in Bytes	Min Value	Max Value	Default Value	Unit
0x45	R	AFEData	String	11+1	—	—	—	—
0x46	R/W	FETControl	hex	2	0x00	0xff	—	—
0x4f	R	StateOfHealth	hex	2	0x0000	0xffff	—	%
0x51	R	SafetyStatus	hex	2	0x0000	0xffff	—	—
0x53	R	PFStatus	hex	2	0x0000	0xffff	—	—
0x54	R	OperationStatus	hex	2	0x0000	0xffff	—	—
0x55	R	ChargingStatus	hex	2	0x0000	0xffff	—	—
0x57	R	ResetData	hex	2	0x0000	0xffff	—	—
0x58	R	WDRResetData	unsigned int	2	0	65535	—	—
0x5a	R	PackVoltage	unsigned int	2	0	65535	—	mV
0x5d	R	AverageVoltage	unsigned int	2	0	65535	—	mV
0x5e	R	TS1Temperature	integer	2	−400	1200	—	0.1°C
0x5f	R	TS2Temperature	integer	2	−400	1200	—	0.1°C
0x60	R/W	UnSealKey	hex	4	0x00000000	0xffffffff	—	—
0x61	R/W	FullAccessKey	hex	4	0x00000000	0xffffffff	—	—
0x62	R/W	PFKey	hex	4	0x00000000	0xffffffff	—	—
0x63	R/W	AuthenKey3	hex	4	0x00000000	0xffffffff	—	—
0x64	R/W	AuthenKey2	hex	4	0x00000000	0xffffffff	—	—
0x65	R/W	AuthenKey1	hex	4	0x00000000	0xffffffff	—	—
0x66	R/W	AuthenKey0	hex	4	0x00000000	0xffffffff	—	—
0x69	R	SafetyStatus2	hex	2	0x0000	0x0003	—	—
0x6b	R	PFStatus2	hex	2	0x0000	0x0003	—	—
0x6c	R/W	ManufBlock1	String	20	—	—	—	—
0x6d	R/W	ManufBlock2	String	20	—	—	—	—
0x6e	R/W	ManufBlock3	String	20	—	—	—	—
0x6f	R/W	ManufBlock4	String	20	—	—	—	—
0x70	R/W	ManufacturerInfo	String	31+1	—	—	—	—
0x71	R/W	SenseResistor	unsigned int	2	0	65535	—	μΩ
0x72	R	TempRange	hex	2	—	—	—	—
0x73	R	LifetimeData	String	32+1	—	—	—	—
0x77	R/W	DataFlashSubClassID	hex	2	0x0000	0xffff	—	—
0x78	R/W	DataFlashSubClassPage1	hex	32	—	—	—	—
0x79	R/W	DataFlashSubClassPage2	hex	32	—	—	—	—
0x7a	R/W	DataFlashSubClassPage3	hex	32	—	—	—	—
0x7b	R/W	DataFlashSubClassPage4	hex	32	—	—	—	—
0x7c	R/W	DataFlashSubClassPage5	hex	32	—	—	—	—
0x7d	R/W	DataFlashSubClassPage6	hex	32	—	—	—	—
0x7e	R/W	DataFlashSubClassPage7	hex	32	—	—	—	—
0x7f	R/W	DataFlashSubClassPage8	hex	32	—	—	—	—

APPLICATION SCHEMATIC

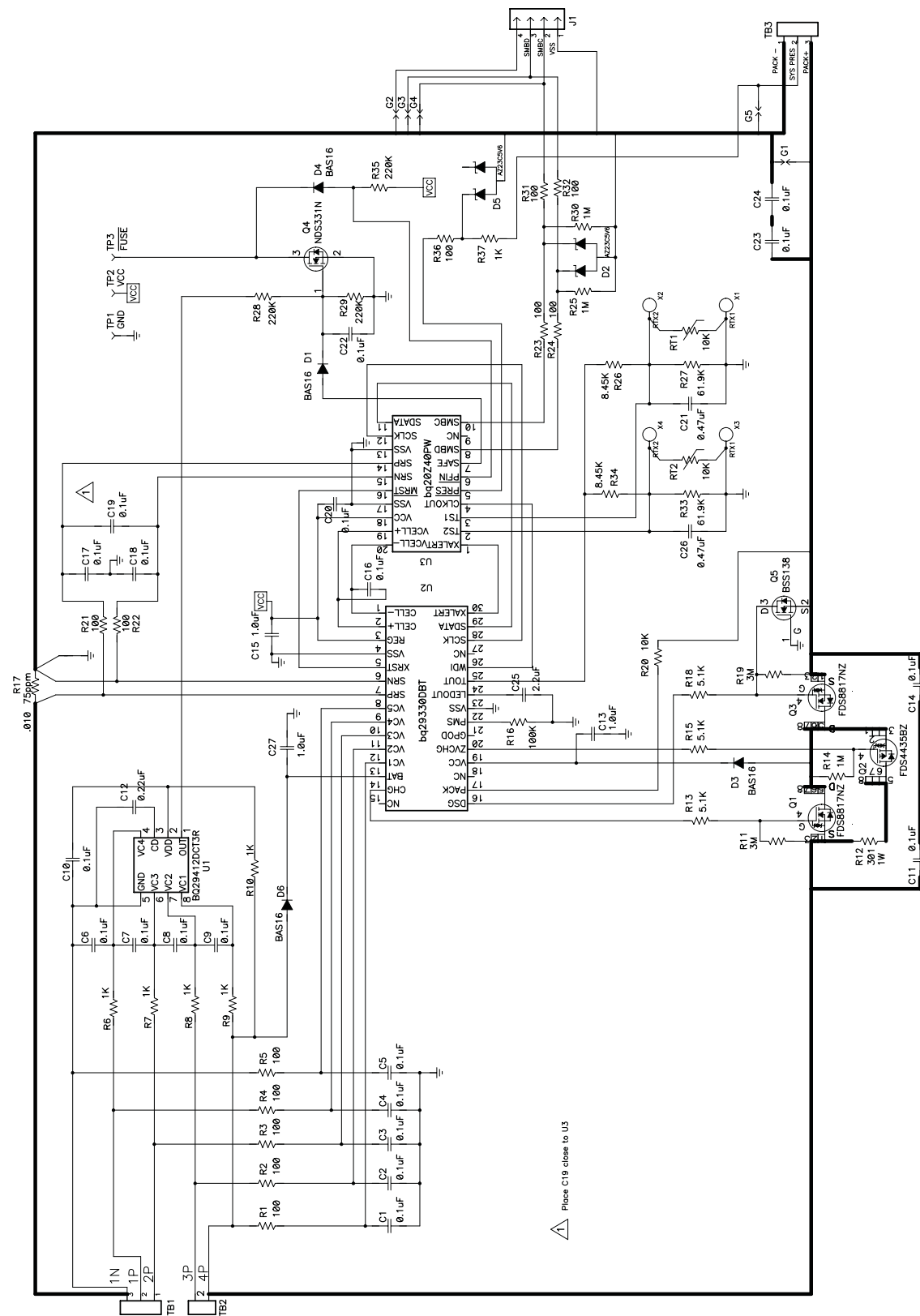

PACKAGING INFORMATION

Orderable Device	Status ⁽¹⁾	Package Type	Package Drawing	Pins	Package Qty	Eco Plan ⁽²⁾	Lead/Ball Finish	MSL Peak Temp ⁽³⁾
BQ20Z40PW	ACTIVE	TSSOP	PW	20	70	Green (RoHS & no Sb/Br)	CU NIPDAU	Level-1-260C-UNLIM
BQ20Z40PWR	ACTIVE	TSSOP	PW	20	2000	Green (RoHS & no Sb/Br)	CU NIPDAU	Level-1-260C-UNLIM

⁽¹⁾ The marketing status values are defined as follows:

ACTIVE: Product device recommended for new designs.

LIFEBUY: TI has announced that the device will be discontinued, and a lifetime-buy period is in effect.

NRND: Not recommended for new designs. Device is in production to support existing customers, but TI does not recommend using this part in a new design.

PREVIEW: Device has been announced but is not in production. Samples may or may not be available.

OBsolete: TI has discontinued the production of the device.

⁽²⁾ Eco Plan - The planned eco-friendly classification: Pb-Free (RoHS), Pb-Free (RoHS Exempt), or Green (RoHS & no Sb/Br) - please check <http://www.ti.com/productcontent> for the latest availability information and additional product content details.

TBD: The Pb-Free/Green conversion plan has not been defined.

Pb-Free (RoHS): TI's terms "Lead-Free" or "Pb-Free" mean semiconductor products that are compatible with the current RoHS requirements for all 6 substances, including the requirement that lead not exceed 0.1% by weight in homogeneous materials. Where designed to be soldered at high temperatures, TI Pb-Free products are suitable for use in specified lead-free processes.

Pb-Free (RoHS Exempt): This component has a RoHS exemption for either 1) lead-based flip-chip solder bumps used between the die and package, or 2) lead-based die adhesive used between the die and leadframe. The component is otherwise considered Pb-Free (RoHS compatible) as defined above.

Green (RoHS & no Sb/Br): TI defines "Green" to mean Pb-Free (RoHS compatible), and free of Bromine (Br) and Antimony (Sb) based flame retardants (Br or Sb do not exceed 0.1% by weight in homogeneous material)

⁽³⁾ MSL, Peak Temp. -- The Moisture Sensitivity Level rating according to the JEDEC industry standard classifications, and peak solder temperature.

Important Information and Disclaimer:The information provided on this page represents TI's knowledge and belief as of the date that it is provided. TI bases its knowledge and belief on information provided by third parties, and makes no representation or warranty as to the accuracy of such information. Efforts are underway to better integrate information from third parties. TI has taken and continues to take reasonable steps to provide representative and accurate information but may not have conducted destructive testing or chemical analysis on incoming materials and chemicals. TI and TI suppliers consider certain information to be proprietary, and thus CAS numbers and other limited information may not be available for release.

In no event shall TI's liability arising out of such information exceed the total purchase price of the TI part(s) at issue in this document sold by TI to Customer on an annual basis.

TAPE AND REEL INFORMATION

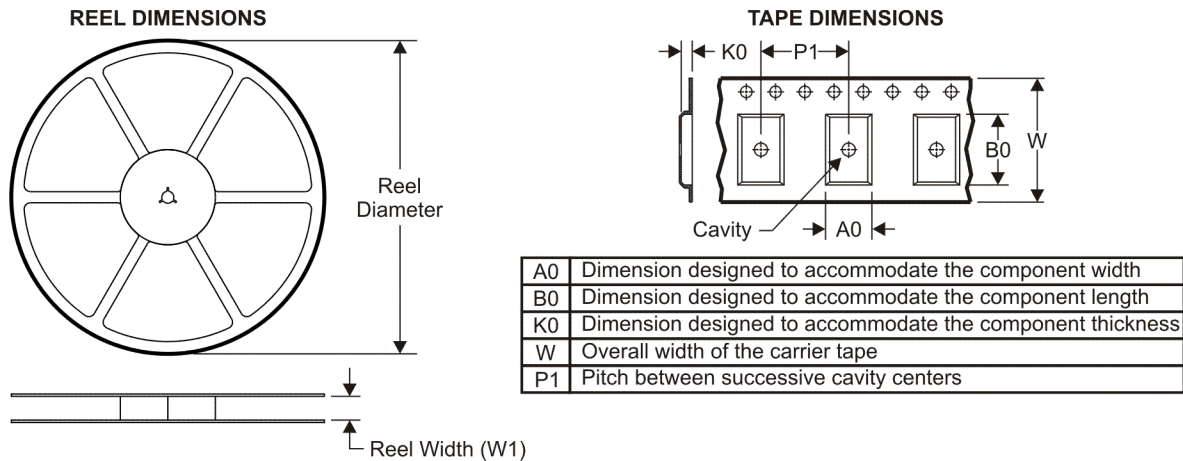

QUADRANT ASSIGNMENTS FOR PIN 1 ORIENTATION IN TAPE



*All dimensions are nominal

Device	Package Type	Package Drawing	Pins	SPQ	Reel Diameter (mm)	Reel Width W1 (mm)	A0 (mm)	B0 (mm)	K0 (mm)	P1 (mm)	W (mm)	Pin1 Quadrant
BQ20Z40PWR	TSSOP	PW	20	2000	330.0	16.4	6.95	7.1	1.6	8.0	16.0	Q1

TAPE AND REEL BOX DIMENSIONS



*All dimensions are nominal

Device	Package Type	Package Drawing	Pins	SPQ	Length (mm)	Width (mm)	Height (mm)
BQ20Z40PWR	TSSOP	PW	20	2000	346.0	346.0	33.0

PW (R-PDSO-G**)

PLASTIC SMALL-OUTLINE PACKAGE

14 PINS SHOWN



4040064/F 01/97

- NOTES: A. All linear dimensions are in millimeters.
 B. This drawing is subject to change without notice.
 C. Body dimensions do not include mold flash or protrusion not to exceed 0,15.
 D. Falls within JEDEC MO-153

IMPORTANT NOTICE

Texas Instruments Incorporated and its subsidiaries (TI) reserve the right to make corrections, modifications, enhancements, improvements, and other changes to its products and services at any time and to discontinue any product or service without notice. Customers should obtain the latest relevant information before placing orders and should verify that such information is current and complete. All products are sold subject to TI's terms and conditions of sale supplied at the time of order acknowledgment.

TI warrants performance of its hardware products to the specifications applicable at the time of sale in accordance with TI's standard warranty. Testing and other quality control techniques are used to the extent TI deems necessary to support this warranty. Except where mandated by government requirements, testing of all parameters of each product is not necessarily performed.

TI assumes no liability for applications assistance or customer product design. Customers are responsible for their products and applications using TI components. To minimize the risks associated with customer products and applications, customers should provide adequate design and operating safeguards.

TI does not warrant or represent that any license, either express or implied, is granted under any TI patent right, copyright, mask work right, or other TI intellectual property right relating to any combination, machine, or process in which TI products or services are used. Information published by TI regarding third-party products or services does not constitute a license from TI to use such products or services or a warranty or endorsement thereof. Use of such information may require a license from a third party under the patents or other intellectual property of the third party, or a license from TI under the patents or other intellectual property of TI.

Reproduction of TI information in TI data books or data sheets is permissible only if reproduction is without alteration and is accompanied by all associated warranties, conditions, limitations, and notices. Reproduction of this information with alteration is an unfair and deceptive business practice. TI is not responsible or liable for such altered documentation. Information of third parties may be subject to additional restrictions.

Resale of TI products or services with statements different from or beyond the parameters stated by TI for that product or service voids all express and any implied warranties for the associated TI product or service and is an unfair and deceptive business practice. TI is not responsible or liable for any such statements.

TI products are not authorized for use in safety-critical applications (such as life support) where a failure of the TI product would reasonably be expected to cause severe personal injury or death, unless officers of the parties have executed an agreement specifically governing such use. Buyers represent that they have all necessary expertise in the safety and regulatory ramifications of their applications, and acknowledge and agree that they are solely responsible for all legal, regulatory and safety-related requirements concerning their products and any use of TI products in such safety-critical applications, notwithstanding any applications-related information or support that may be provided by TI. Further, Buyers must fully indemnify TI and its representatives against any damages arising out of the use of TI products in such safety-critical applications.

TI products are neither designed nor intended for use in military/aerospace applications or environments unless the TI products are specifically designated by TI as military-grade or "enhanced plastic." Only products designated by TI as military-grade meet military specifications. Buyers acknowledge and agree that any such use of TI products which TI has not designated as military-grade is solely at the Buyer's risk, and that they are solely responsible for compliance with all legal and regulatory requirements in connection with such use.

TI products are neither designed nor intended for use in automotive applications or environments unless the specific TI products are designated by TI as compliant with ISO/TS 16949 requirements. Buyers acknowledge and agree that, if they use any non-designated products in automotive applications, TI will not be responsible for any failure to meet such requirements.

Following are URLs where you can obtain information on other Texas Instruments products and application solutions:

Products

Amplifiers	amplifier.ti.com
Data Converters	dataconverter.ti.com
DLP® Products	www.dlp.com
DSP	dsp.ti.com
Clocks and Timers	www.ti.com/clocks
Interface	interface.ti.com
Logic	logic.ti.com
Power Mgmt	power.ti.com
Microcontrollers	microcontroller.ti.com
RFID	www.ti-rfid.com
RF/IF and ZigBee® Solutions	www.ti.com/lprf

Applications

Audio	www.ti.com/audio
Automotive	www.ti.com/automotive
Broadband	www.ti.com/broadband
Digital Control	www.ti.com/digitalcontrol
Medical	www.ti.com/medical
Military	www.ti.com/military
Optical Networking	www.ti.com/opticalnetwork
Security	www.ti.com/security
Telephony	www.ti.com/telephony
Video & Imaging	www.ti.com/video
Wireless	www.ti.com/wireless

Mailing Address: Texas Instruments, Post Office Box 655303, Dallas, Texas 75265
Copyright © 2009, Texas Instruments Incorporated