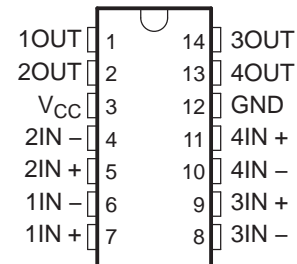

LOW-POWER QUAD DIFFERENTIAL COMPARATOR

FEATURES

- Qualified for Automotive Applications
- Wide Supply-Voltage Range . . . 3 V to 30 V
- Ultra-Low Power-Supply Current Drain . . . 60 μ A Typ
- Low Input Biasing Current . . . 3 nA
- Low Input Offset Current . . . ± 0.5 nA
- Low Input Offset Voltage . . . ± 2 mV
- Common-Mode Input Voltage Includes Ground
- Output Voltage Compatible With MOS and CMOS Logic
- High Output Sink-Current Capability (30 mA at $V_O = 2$ V)
- Power-Supply Input Reverse Voltage Protected
- Single Power-Supply Operation
- Pin-for-Pin Compatible With LM239, LM339, LM2901

**D PACKAGE
(TOP VIEW)**

DESCRIPTION/ORDERING INFORMATION

The LP2901 is a low-power quadruple differential comparator. The device consists of four independent voltage comparators designed specifically to operate from a single power supply and, typically, to draw 60- μ A drain current over a wide range of voltages. Operation from split power supplies also is possible, and the ultra-low power-supply drain current is independent of the power-supply voltage.

Applications include limit comparators, simple analog-to-digital converters, pulse generators, square-wave generators, time-delay generators, voltage-controlled oscillators, multivibrators, and high-voltage logic gates. The LP2901 is designed specifically to interface with the CMOS logic family. The ultra-low power-supply current makes these products desirable in battery-powered applications.

The LP2901 is characterized for operation from -40°C to 85°C .

ORDERING INFORMATION⁽¹⁾

T_A	$V_{IO\text{MAX}}$ AT 25°C	PACKAGE ⁽²⁾		ORDERABLE PART NUMBER	TOP-SIDE MARKING
-40°C to 85°C	± 5 mV	SOIC – D	Reel of 2500	LP2901IDRQ1	LP2901IQ1

(1) For the most current package and ordering information, see the Package Option Addendum at the end of this document, or see the TI web site at www.ti.com.

(2) Package drawings, thermal data, and symbolization are available at www.ti.com/packaging.



Please be aware that an important notice concerning availability, standard warranty, and use in critical applications of Texas Instruments semiconductor products and disclaimers thereto appears at the end of this data sheet.

SCHEMATIC DIAGRAM (EACH COMPARATOR)

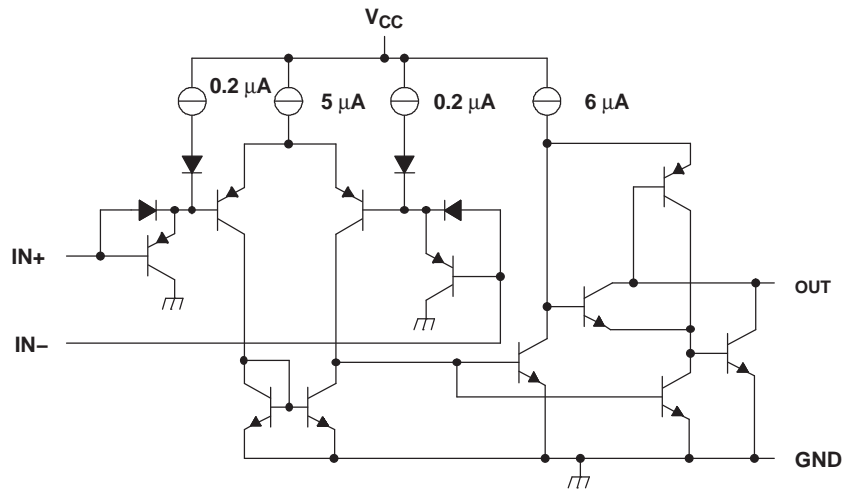

Absolute Maximum Ratings⁽¹⁾

over operating free-air temperature range (unless otherwise noted)

		MIN	MAX	UNIT
V_{CC}	Supply voltage ⁽²⁾		36	V
V_{ID}	Differential input voltage range ⁽³⁾		±36	V
V_I	Input voltage range (either input)	-0.3	36	V
I_I	Input current ⁽⁴⁾		-50	mA
		$V_I \leq -0.3$ V		
	Duration of output short-circuit to ground ⁽⁵⁾	Unlimited		
	Continuous total power dissipation ⁽⁶⁾	See Dissipation Rating Table		
θ_{JA}	Package thermal impedance ⁽⁷⁾⁽⁸⁾		133.5	°C/W
T_A	Operating free-air temperature range	-40	85	°C
T_J	Operating virtual junction temperature		150	°C
T_{lead}	Lead temperature range		300	°C
		1,6 mm (1/16 in) from case for 60 s		
T_{stg}	Storage temperature range	-65	150	°C

- (1) Stresses beyond those listed under "absolute maximum ratings" may cause permanent damage to the device. These are stress ratings only, and functional operation of the device at these or any other conditions beyond those indicated under "recommended operating conditions" is not implied. Exposure to absolute-maximum-rated conditions for extended periods may affect device reliability.
- (2) All voltage values, except differential voltages, are with respect to the network ground.
- (3) Differential voltages are at IN+ with respect to IN-.
- (4) This input current exists only when the voltage at any of the inputs is driven negative. The current flows through the collector-base junction of the input clamping device. In addition to the clamping device action, there is lateral n-p-n parasitic transistor action. This action is not destructive, and normal output states are reestablished when the input voltage returns to a value more positive than -0.3 V at $T_A = 25^\circ\text{C}$.
- (5) Short circuits between outputs to V_{CC} can cause excessive heating and eventual destruction.
- (6) If the output transistors are allowed to saturate, the low-bias dissipation and the on-off characteristics of the outputs keep the dissipation very small (usually less than 100 mW).
- (7) Maximum power dissipation is a function of $T_J(\text{max})$, θ_{JA} , and T_A . The maximum allowable power dissipation at any allowable ambient temperature is $P_D = (T_J(\text{max}) - T_A)/\theta_{JA}$. Operating at the absolute maximum T_J of 150°C can impact reliability.
- (8) The package thermal impedance is calculated in accordance with JEDEC 51 (low-K board).

Dissipation Ratings

PACKAGE	$T_A \leq 25^\circ\text{C}$ POWER RATING	DERATING FACTOR ABOVE $T_A = 25^\circ\text{C}$	$T_A = 70^\circ\text{C}$ POWER RATING	$T_A = 85^\circ\text{C}$ POWER RATING
D	936 mW	7.49 mW/°C	599 mW	486 mW

Recommended Operating Conditions

			MIN	MAX	UNIT
V_{CC}	Supply voltage		3	30	V
V_{IC}	Common-mode input voltage	$V_{CC} = 5\text{ V}$	0	3	V
		$V_{CC} = 30\text{ V}$	0	28	
V_I	Input voltage	$V_{CC} = 5\text{ V}$	0	3	V
		$V_{CC} = 30\text{ V}$	0	28	
T_A	Operating free-air temperature		-40	85	°C

Electrical Characteristics

 $V_{CC} = 5\text{ V}$, $T_A = 25^\circ\text{C}$ (unless otherwise noted)

PARAMETER	TEST CONDITIONS		T_A ⁽¹⁾	MIN	TYP	MAX	UNIT
V_{IO}	Input offset voltage	$V_{CC} = 5\text{ V to } 30\text{ V}$, $V_O = 2\text{ V}$ ⁽²⁾ , $R_S = 0$	25°C		±2	±5	mV
			Full range			±9	
I_{IO}	Input offset current		25°C		±0.5	±5	nA
			Full range		±1	±15	
I_{IB}	Input bias current ⁽³⁾		25°C		-2.5	-25	nA
			Full range		-4	-40	
V_{ICR}	Common-mode input voltage range	Single supply	25°C	0 to $V_{CC} - 1.5$		V	
			Full range	0 to $V_{CC} - 2$			
A_{VD}	Large-signal differential voltage amplification	$V_{CC} = 15\text{ V}$, $R_L = 15\text{ k}\Omega$		500		V/mV	
Output sink current	$V_{I-} = 1\text{ V}$, $V_{I+} = 0$	$V_O = 2\text{ V}$ ⁽⁴⁾	25°C	20	30	mA	
			Full range	15			
Output leakage current	$V_{I+} = 1\text{ V}$, $V_{I-} = 0$	$V_O = 0.4\text{ V}$	25°C	0.2	0.7	nA	
		$V_O = 5\text{ V}$	25°C	0.1		nA	
I_{CC}	Supply current	$R_L = \infty$, All comparators	Full range			1	μA
						36	V
V_{ID}	Differential input voltage	$V_I \leq 0$ (or V_{CC-} on split supplies)				36	V
I_{CC}	Supply current	$R_L = \infty$, All comparators		60	100	μA	

(1) Full range is -40°C to 125°C .

(2) V_{IO} is measured over the full common-mode input voltage range.

(3) Because of the p-n-p input stage, the direction of the current is out of the device. This current essentially is constant (i.e., independent of the output state). No loading change exists on the reference or input lines as long as the common-mode input voltage range is not exceeded.

(4) The output sink current is a function of the output voltage. These devices have a bimodal output section that allows them to sink (via a Darlington connection) large currents at output voltages greater than 1.5 V and smaller currents at output voltages less than 1.5 V.

Switching Characteristics

 $V_{CC} = 5\text{ V}$, $T_A = 25^\circ\text{C}$, R_L connected to 5 V through 5.1 kΩ

PARAMETER	TEST CONDITIONS	TYP	UNIT
Large-signal response time	TTL logic swing, $V_{ref} = 1.4\text{ V}$	1.3	μs
Response time		8	

APPLICATION INFORMATION

Figure 1 shows the basic configuration for using the LP2901 comparator. Figure 2 shows the diagram for using it as a CMOS driver.

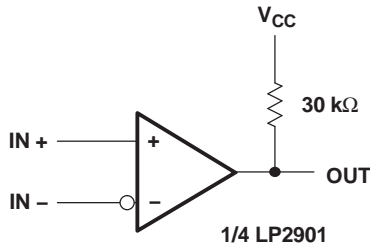

Figure 1. Basic Comparator

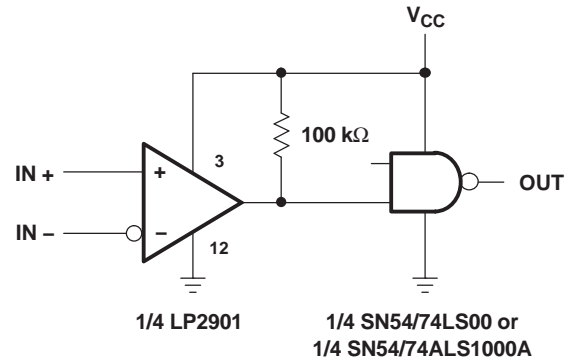

Figure 2. CMOS Driver

All pins of any unused comparators should be grounded. The bias network of the LP2901 establishes a drain current that is independent of the magnitude of the power-supply voltage over the range of 2 V to 30 V. It usually is necessary to use a bypass capacitor across the power-supply line.

The differential input voltage may be larger than V_{CC} without damaging the device. Protection should be provided to prevent the input voltages from going negative by more than -0.3 V. The output section has two distinct modes of operation, the Darlington mode and the ground-emitter mode. This unique drive circuit permits the device to sink 30 mA at $V_O = 2$ V in the Darlington mode and 700 μ A at $V_O = 0.4$ V in the ground-emitter mode. Figure 3 is a simplified schematic diagram of the output section. The output section is configured in a Darlington connection (ignoring Q3). If the output voltage is held high enough (above 1 V), Q1 is not saturated and the output current is limited only by the product of the h_{FE} of Q1, the h_{FE} of Q2, and I_1 and the 60- Ω saturation resistance of Q2. The devices are capable of driving LEDs, relays, etc. in this mode while maintaining an ultra-low power-supply current of 60 μ A typical.

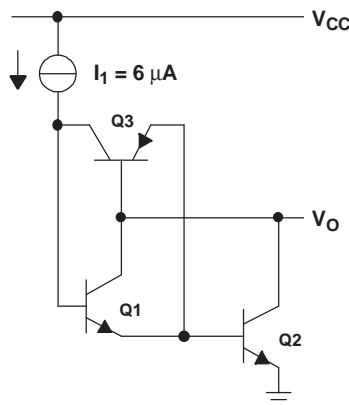

Figure 3. Output-Section Schematic Diagram

Without transistor Q3, if the output voltage were allowed to drop below 0.8 V, transistor Q1 would saturate, and the output current would drop to zero. The circuit would be unable to pull low current loads down to ground or the negative supply, if used. Transistor Q3 has been included to bypass transistor Q1 under these conditions and apply the current I_1 directly to the base of Q2. The output sink current now is approximately I_1 times the h_{FE} of Q2 (700 μ A at $V_O = 0.4$ V). The output of the devices exhibits a bimodal characteristic, with a smooth transition between modes.

In both cases, the output is an uncommitted collector. Several outputs can be tied together to provide a dot logic function. An output pullup resistor can be connected to any available power-supply voltage within the permitted power-supply range, and there is no restriction on this voltage, based on the magnitude of the voltage that is supplied to V_{CC} of the package.

PACKAGING INFORMATION

Orderable Device	Status (1)	Package Type	Package Drawing	Pins	Package Qty	Eco Plan (2)	Lead finish/ Ball material (6)	MSL Peak Temp (3)	Op Temp (°C)	Device Marking (4/5)	Samples
LP2901IDRG4Q1	LIFEBUY	SOIC	D	14	2500	RoHS & Green	NIPDAU	Level-1-260C-UNLIM	-40 to 85	LP29011Q1	
LP2901IDRQ1	ACTIVE	SOIC	D	14	2500	RoHS & Green	NIPDAU	Level-1-260C-UNLIM	-40 to 85	LP29011Q1	Samples

(1) The marketing status values are defined as follows:

ACTIVE: Product device recommended for new designs.

LIFEBUY: TI has announced that the device will be discontinued, and a lifetime-buy period is in effect.

NRND: Not recommended for new designs. Device is in production to support existing customers, but TI does not recommend using this part in a new design.

PREVIEW: Device has been announced but is not in production. Samples may or may not be available.

OBSELETE: TI has discontinued the production of the device.

(2) **RoHS:** TI defines "RoHS" to mean semiconductor products that are compliant with the current EU RoHS requirements for all 10 RoHS substances, including the requirement that RoHS substance do not exceed 0.1% by weight in homogeneous materials. Where designed to be soldered at high temperatures, "RoHS" products are suitable for use in specified lead-free processes. TI may reference these types of products as "Pb-Free".

RoHS Exempt: TI defines "RoHS Exempt" to mean products that contain lead but are compliant with EU RoHS pursuant to a specific EU RoHS exemption.

Green: TI defines "Green" to mean the content of Chlorine (Cl) and Bromine (Br) based flame retardants meet JS709B low halogen requirements of <=1000ppm threshold. Antimony trioxide based flame retardants must also meet the <=1000ppm threshold requirement.

(3) MSL, Peak Temp. - The Moisture Sensitivity Level rating according to the JEDEC industry standard classifications, and peak solder temperature.

(4) There may be additional marking, which relates to the logo, the lot trace code information, or the environmental category on the device.

(5) Multiple Device Markings will be inside parentheses. Only one Device Marking contained in parentheses and separated by a "~" will appear on a device. If a line is indented then it is a continuation of the previous line and the two combined represent the entire Device Marking for that device.

(6) Lead finish/Ball material - Orderable Devices may have multiple material finish options. Finish options are separated by a vertical ruled line. Lead finish/Ball material values may wrap to two lines if the finish value exceeds the maximum column width.

Important Information and Disclaimer:The information provided on this page represents TI's knowledge and belief as of the date that it is provided. TI bases its knowledge and belief on information provided by third parties, and makes no representation or warranty as to the accuracy of such information. Efforts are underway to better integrate information from third parties. TI has taken and continues to take reasonable steps to provide representative and accurate information but may not have conducted destructive testing or chemical analysis on incoming materials and chemicals. TI and TI suppliers consider certain information to be proprietary, and thus CAS numbers and other limited information may not be available for release.

In no event shall TI's liability arising out of such information exceed the total purchase price of the TI part(s) at issue in this document sold by TI to Customer on an annual basis.

OTHER QUALIFIED VERSIONS OF LP2901-Q1 :

- Catalog : [LP2901](#)

NOTE: Qualified Version Definitions:

- Catalog - TI's standard catalog product

D (R-PDSO-G14)

PLASTIC SMALL OUTLINE



- NOTES:
- A. All linear dimensions are in inches (millimeters).
 - B. This drawing is subject to change without notice.
 - Body length does not include mold flash, protrusions, or gate burrs. Mold flash, protrusions, or gate burrs shall not exceed 0.006 (0,15) each side.
 - Body width does not include interlead flash. Interlead flash shall not exceed 0.017 (0,43) each side.
 - E. Reference JEDEC MS-012 variation AB.

IMPORTANT NOTICE AND DISCLAIMER

TI PROVIDES TECHNICAL AND RELIABILITY DATA (INCLUDING DATA SHEETS), DESIGN RESOURCES (INCLUDING REFERENCE DESIGNS), APPLICATION OR OTHER DESIGN ADVICE, WEB TOOLS, SAFETY INFORMATION, AND OTHER RESOURCES "AS IS" AND WITH ALL FAULTS, AND DISCLAIMS ALL WARRANTIES, EXPRESS AND IMPLIED, INCLUDING WITHOUT LIMITATION ANY IMPLIED WARRANTIES OF MERCHANTABILITY, FITNESS FOR A PARTICULAR PURPOSE OR NON-INFRINGEMENT OF THIRD PARTY INTELLECTUAL PROPERTY RIGHTS.

These resources are intended for skilled developers designing with TI products. You are solely responsible for (1) selecting the appropriate TI products for your application, (2) designing, validating and testing your application, and (3) ensuring your application meets applicable standards, and any other safety, security, regulatory or other requirements.

These resources are subject to change without notice. TI grants you permission to use these resources only for development of an application that uses the TI products described in the resource. Other reproduction and display of these resources is prohibited. No license is granted to any other TI intellectual property right or to any third party intellectual property right. TI disclaims responsibility for, and you will fully indemnify TI and its representatives against, any claims, damages, costs, losses, and liabilities arising out of your use of these resources.

TI's products are provided subject to [TI's Terms of Sale](#) or other applicable terms available either on [ti.com](https://www.ti.com) or provided in conjunction with such TI products. TI's provision of these resources does not expand or otherwise alter TI's applicable warranties or warranty disclaimers for TI products.

TI objects to and rejects any additional or different terms you may have proposed.

Mailing Address: Texas Instruments, Post Office Box 655303, Dallas, Texas 75265
Copyright © 2023, Texas Instruments Incorporated