

Stereo Audio Volume Control

FEATURES

- **DIGITALLY-CONTROLLED ANALOG VOLUME CONTROL:**
 - Two Independent Audio Channels
 - Serial Control Interface
 - Zero Crossing Detection
 - Mute Function
- **WIDE GAIN AND ATTENUATION RANGE:**
 - +31.5dB to -95.5dB with 0.5dB Steps
- **LOW NOISE AND DISTORTION:**
 - 120dB Dynamic Range
 - 0.0004% THD+N at 1kHz
- **LOW INTERCHANNEL CROSSTALK:**
 - 126dBFS
- **NOISE-FREE LEVEL TRANSITIONS**
- **POWER SUPPLIES: ±15V Analog, +5V Digital**
- **AVAILABLE IN DIP-16 AND SOL-16 PACKAGES**
- **PIN AND SOFTWARE COMPATIBLE WITH THE PGA2311 AND CIRRUS LOGIC CS3310™**

APPLICATIONS

- **AUDIO AMPLIFIERS**
- **MIXING CONSOLES**
- **MULTI-TRACK RECORDERS**
- **BROADCAST STUDIO EQUIPMENT**
- **MUSICAL INSTRUMENTS**
- **EFFECTS PROCESSORS**
- **A/V RECEIVERS**
- **CAR AUDIO SYSTEMS**

DESCRIPTION

The PGA2310 is a high-performance, stereo audio volume control designed for professional and high-end consumer audio systems. The ability to operate from $\pm 15V$ analog power supplies enables the PGA2310 to process input signals with large voltage swings, thereby preserving the dynamic range available in the overall signal path. Using high performance operational amplifier stages internal to the PGA2310 yields low noise and distortion, while providing the capability to drive 600Ω loads directly without buffering. The three-wire serial control interface allows for connection to a wide variety of host controllers, in addition to support for daisy-chaining of multiple PGA2310 devices.



Please be aware that an important notice concerning availability, standard warranty, and use in critical applications of Texas Instruments semiconductor products and disclaimers thereto appears at the end of this data sheet.

All trademarks are the property of their respective owners.

PGA2310

SBOS207B – OCTOBER 2001 – REVISED JUNE 2004



This integrated circuit can be damaged by ESD. Texas Instruments recommends that all integrated circuits be handled with appropriate precautions. Failure to observe proper handling and installation procedures can cause damage.

ESD damage can range from subtle performance degradation to complete device failure. Precision integrated circuits may be more susceptible to damage because very small parametric changes could cause the device not to meet its published specifications.

ABSOLUTE MAXIMUM RATINGS

over operating free-air temperature range unless otherwise noted⁽¹⁾

		PGA2310	UNIT
Supply voltage	V _{A+}	+16.0	V
	V _{A-}	-16.0	V
	V _{D+}	+6.5	V
Analog input voltage		0 to V _{A+} , V _{A-}	V
Digital input voltage		-0.3 to V _{D+}	V
Operating temperature range		-55 to +125	°C
Storage temperature range		-65 to +150	°C
Junction temperature		+150	°C
Lead temperature (soldering, 10s)		+300	°C
Package temperature (IR, reflow, 10s)		+235	°C

⁽¹⁾ Stresses above those listed under *Absolute Maximum Ratings* may cause permanent damage to the device. Exposure to absolute maximum conditions for extended periods may degrade device reliability. These are stress ratings only, and functional operation of the device at these or any other conditions beyond those specified is not implied.

ORDERING INFORMATION⁽¹⁾

PRODUCT	PACKAGE-LEAD	PACKAGE DESIGNATOR	SPECIFIED TEMPERATURE RANGE	PACKAGE MARKING	ORDERING NUMBER	TRANSPORT MEDIA, QUANTITY
PGA2310	DIP-16	N	-40°C to +85°C	PGA2310PA	PGA2310PA	Rails, 25
	SOL-16	DW		PGA2310UA	PGA2310UA	Rails, 48
				PGA2310UA	PGA2310UA/1K	Tape and Reel, 1000

⁽¹⁾ For the most current package and ordering information, see the Package Option Addendum located at the end of this data sheet.

ELECTRICAL CHARACTERISTICS

At $T_A = +25^\circ\text{C}$, $V_{A+} = +15\text{V}$, $V_{A-} = -15\text{V}$, $V_{D+} = +5\text{V}$, $R_L = 100\text{k}\Omega$, $C_L = 20\text{pF}$, BW measure = 10Hz to 20kHz, unless otherwise noted.

PARAMETER	TEST CONDITIONS	PGA2310			UNIT
		MIN	TYP	MAX	
DC CHARACTERISTICS					
Step Size			0.5		dB
Gain Error	Gain Setting = 31.5dB		± 0.05		dB
Gain Matching			± 0.05		dB
Input Resistance			10		$\text{k}\Omega$
Input Capacitance			7		pF
AC CHARACTERISTICS					
THD+N	$V_{IN} = 10\text{V}_{pp}$, $f = 1\text{kHz}$		0.0004	0.001	%
Dynamic Range	$V_{IN} = \text{AGND}$, Gain = 0dB	116	120		dB
Voltage Range, Input and Output		$(V_{A-}) + 1.5$		$(V_{A-}) - 1.5$	V
Output Noise	$V_{IN} = \text{AGND}$, Gain = 0dB		9.5	13.5	μV_{RMS}
Interchannel Crosstalk	$f = 1\text{kHz}$		-126		dBFS
OUTPUT BUFFER					
Offset Voltage	$V_{IN} = \text{AGND}$, Gain = 0dB		0.5	3	mV
Load Capacitance Stability			1000		pF
Short-Circuit Current			35		mA
Unity-Gain Bandwidth, Small Signal			1.5		MHz
DIGITAL CHARACTERISTICS					
High-Level Input Voltage, V_{IH}		+2.0		V_{D+}	V
Low-Level Input Voltage, V_{IL}		-0.3		0.8	V
High-Level Output Voltage, V_{OH}	$I_O = 200\mu\text{A}$	$(V_{D+}) - 1.0$			V
Low-Level Output Voltage, V_{OL}	$I_O = -3.2\text{mA}$			0.4	V
Input Leakage Current			1	10	μA
SWITCHING CHARACTERISTICS					
Serial Clock (SCLK) Frequency	t_{SCLK}	0		6.25	MHz
Serial Clock (SCLK) Pulse Width Low	t_{PH}	80			ns
Serial Clock (SCLK) Pulse Width High	t_{PL}	80			ns
MUTE Pulse Width Low	t_{MI}	2.0			ms
Input Timing					
SDI Setup Time	t_{SDS}	20			ns
SDI Hold Time	t_{SDH}	20			ns
$\overline{\text{CS}}$ Falling to SCLK Rising	t_{CSCR}	90			ns
SCLK Falling to $\overline{\text{CS}}$ Rising	t_{CFCS}	35			ns
Output Timing					
$\overline{\text{CS}}$ Low to SDO Active	t_{CSO}			35	ns
SCLK Falling to SDO Data Valid	t_{CFDO}			60	ns
$\overline{\text{CS}}$ High to SDO High Impedance	t_{CSZ}			100	ns
POWER SUPPLY					
Operating Voltage					
V_{A+}		+4.5	+15	+15.5	V
V_{A-}		-4.5	-15	-15.5	V
V_{D+}		+4.5	+5	+5.5	V
Quiescent Current					
I_{A+}	$V_{A+} = +15\text{V}$		7.5	10	mA
I_{A-}	$V_{A-} = -15\text{V}$		7.7	10	mA
I_{D+}	$V_{D+} = +5\text{V}$		0.8	1.5	mA

PGA2310

SBOS207B – OCTOBER 2001 – REVISED JUNE 2004

ELECTRICAL CHARACTERISTICS (continued)

 At $T_A = +25^\circ\text{C}$, $V_{A+} = +15\text{V}$, $V_{A-} = -15\text{V}$, $V_{D+} = +5\text{V}$, $R_L = 100\text{k}\Omega$, $C_L = 20\text{pF}$, BW measure = 10Hz to 20kHz, unless otherwise noted.

PARAMETER	TEST CONDITIONS	PGA2310			UNIT
		MIN	TYP	MAX	
TEMPERATURE RANGE					
Specified Range		-40		+85	$^\circ\text{C}$
Operating Range		-55		+125	$^\circ\text{C}$
Storage Range		-65		+150	$^\circ\text{C}$
Thermal Resistance, θ_{JC}					
DIP-16			60		$^\circ\text{C/W}$
SOL-16			50		$^\circ\text{C/W}$

PIN CONFIGURATION

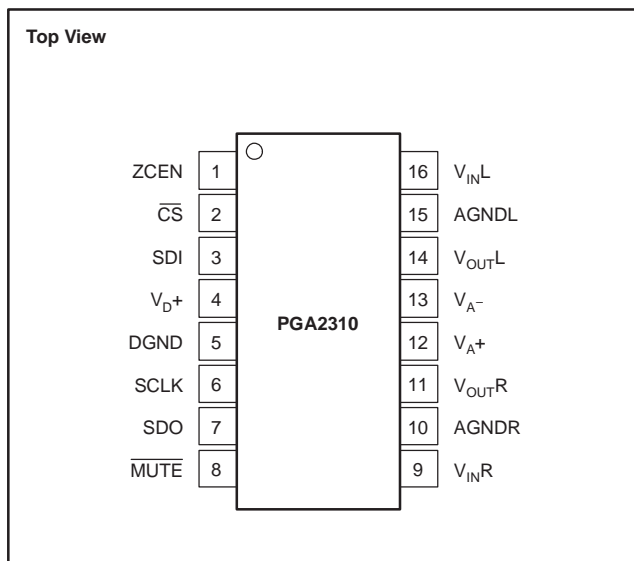

PIN ASSIGNMENTS

PIN	NAME	FUNCTION
1	ZCEN	Zero Crossing Enable Input (Active High)
2	$\overline{\text{CS}}$	Chip Select Input (Active Low)
3	SDI	Serial Data input
4	V_{D+}	Digital Power Supply, +5V
5	DGND	Digital Ground
6	SCLK	Serial Clock Input
7	SDO	Serial Data Output
8	$\overline{\text{MUTE}}$	Mute Control Input (Active Low)
9	V_{INR}	Analog Input, Right Channel
10	AGNDR	Analog Ground, Right Channel
11	V_{OUTR}	Analog Output, Right Channel
12	V_{A+}	Analog Power Supply, +15V
13	V_{A-}	Analog Power Supply, -15V
14	V_{OUTL}	Analog Output, Left Channel
15	AGNDL	Analog Ground, Left Channel
16	V_{INL}	Analog Input, Left Channel

TYPICAL CHARACTERISTICS

At $T_A = +25^\circ\text{C}$, $V_{A+} = +15\text{V}$, $V_{A-} = -15\text{V}$, $V_{D+} = +5\text{V}$, $R_L = 100\text{k}\Omega$, $C_L = 20\text{pF}$, BW measure = 10Hz to 20kHz, unless otherwise noted.

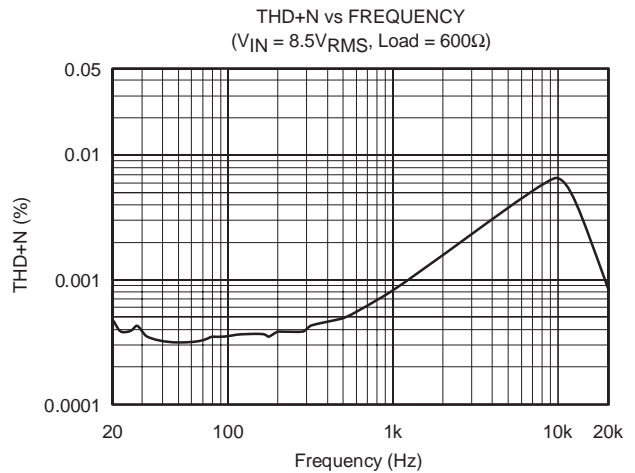
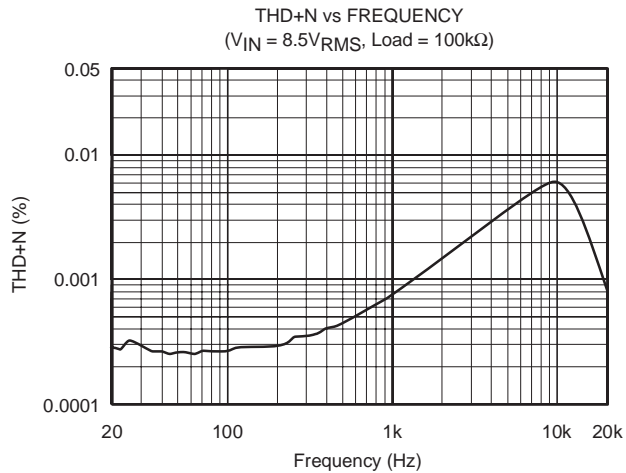
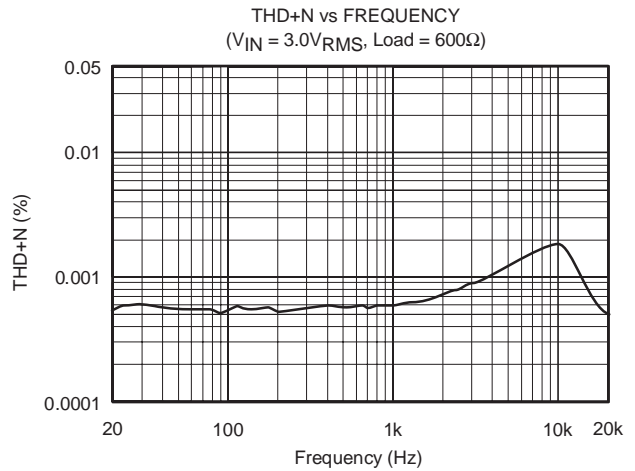
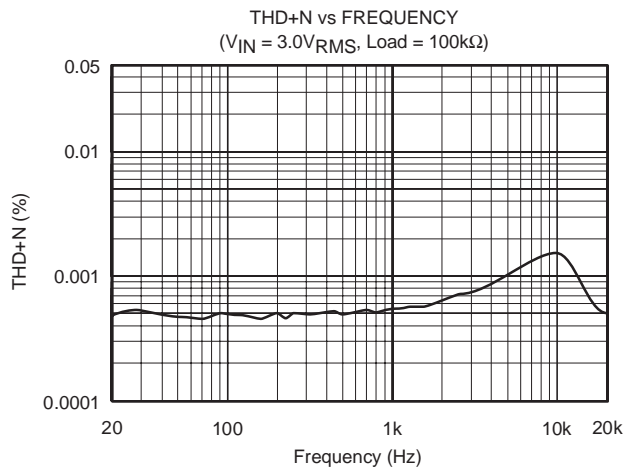
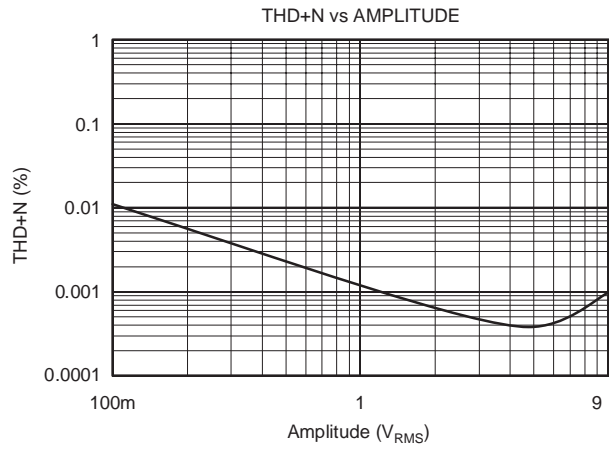
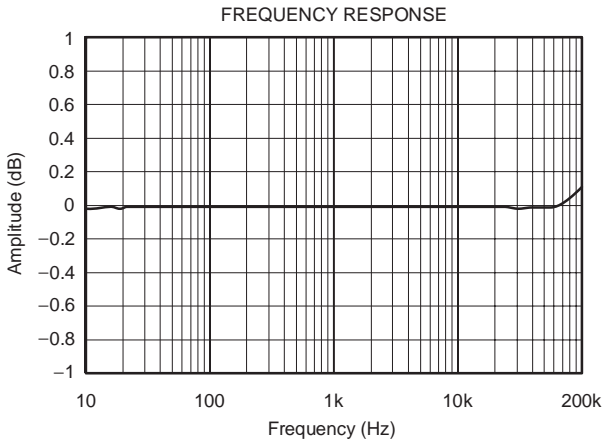

PGA2310

SBOS207B – OCTOBER 2001 – REVISED JUNE 2004

TYPICAL CHARACTERISTICS (continued)

At $T_A = +25^\circ\text{C}$, $V_{A+} = +15\text{V}$, $V_{A-} = -15\text{V}$, $V_{D+} = +5\text{V}$, $R_L = 100\text{k}\Omega$, $C_L = 20\text{pF}$, BW measure = 10Hz to 20kHz, unless otherwise noted.

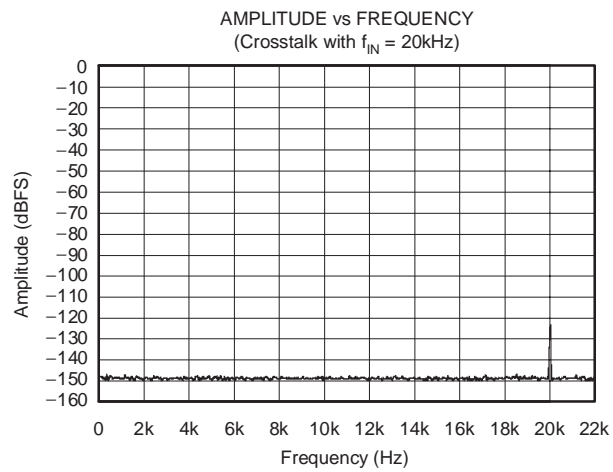
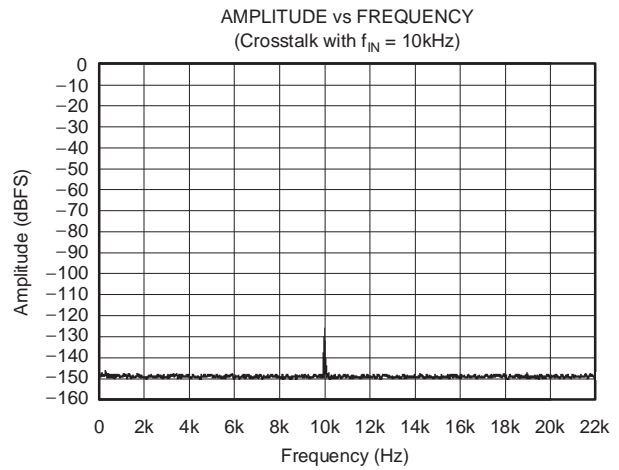
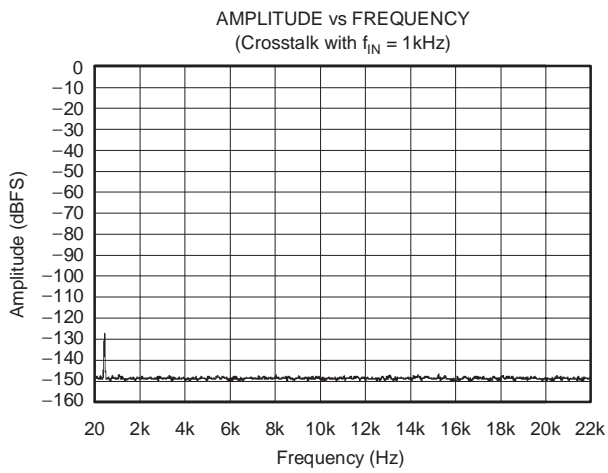

GENERAL DESCRIPTION

The PGA2310 is a stereo audio volume control. It may be used in a wide array of professional and consumer audio equipment. The PGA2310 is fabricated in a mixed-signal BiCMOS process, as to take advantage of the superior analog characteristics for which it offers.

The heart of the PGA2310 is a resistor network, an analog switch array, and a high-performance bipolar op amp stage. The switches are used to select taps in the resistor network that, in turn, determine the gain of the amplifier stage. Switch selections are programmed using a serial control port. The serial port allows connection to a wide variety of host controllers. Figure 1 shows a functional block diagram of the PGA2310.

POWER-UP STATE

On power up, all internal flip-flops are reset. The gain byte value for both the left and right channels are set to 00_{HEX}, or mute condition. The gain will remain at this setting until the host controller programs new settings for each channel via the serial control port.

ANALOG INPUTS AND OUTPUTS

The PGA2310 includes two independent channels, referred to as the left and right channels. Each channel has a corresponding input and output pin. The input and output pins are unbalanced, or referenced to analog ground (either AGNDR or AGNDL). The inputs are named V_{INR} (pin 9) and V_{INL} (pin 16), while the outputs are named V_{OUTR} (pin 11) and V_{OUTL} (pin 14).

The input and output pins may swing within 1.5V of the analog power supplies, V_{A+} (pin 12) and V_{A-} (pin 13). Given $V_{A+} = +15V$ and $V_{A-} = -15V$, the maximum input or output voltage range is 27V_{PP}.

It is important to drive the PGA2310 with a low source impedance. If a source impedance of greater than 600Ω is used, the distortion performance of the PGA2310 will begin to degrade.

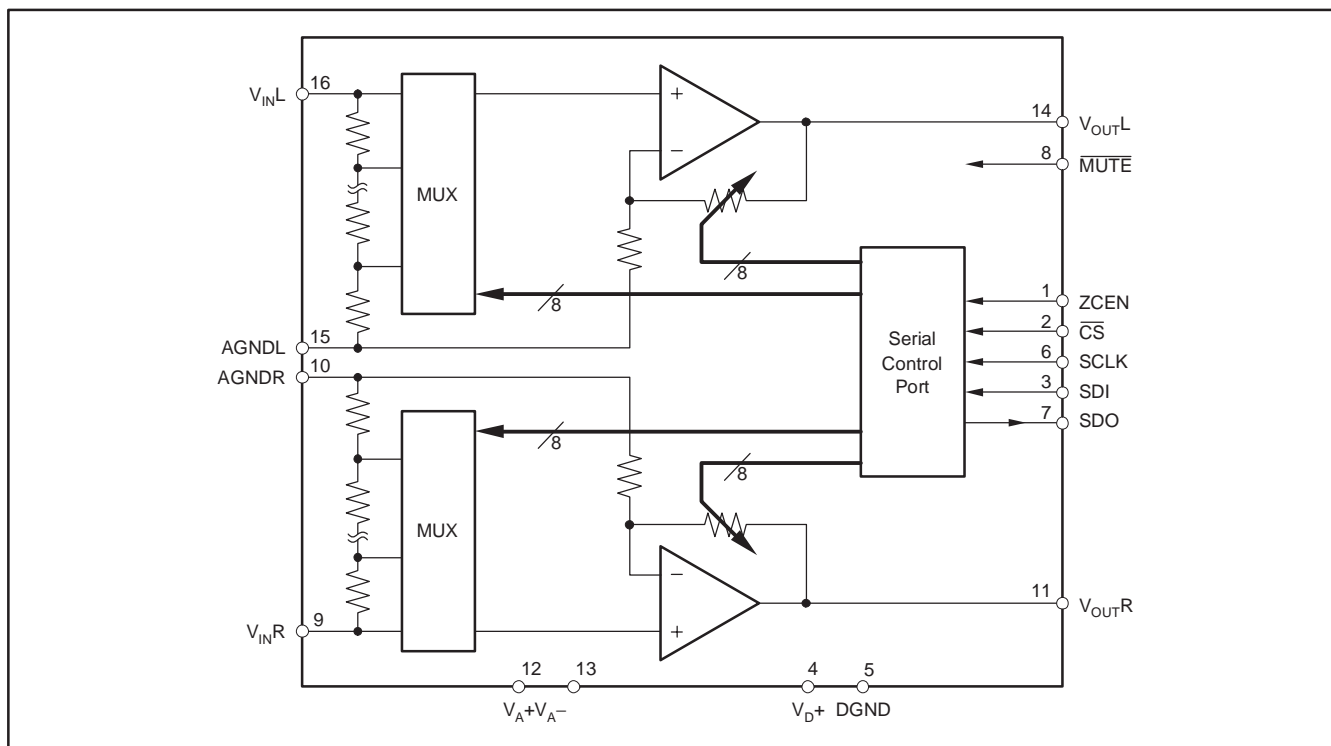

Figure 1. PGA2310 Block Diagram

PGA2310

SBOS207B – OCTOBER 2001 – REVISED JUNE 2004

SERIAL CONTROL PORT

The serial control port is utilized to program the gain settings for the PGA2310. The serial control port includes three input pins and one output pin. The inputs include \overline{CS} (pin 2), SDI (pin 3), and SCLK (pin 6). The sole output pin is SDO (pin 7).

The \overline{CS} pin functions as the chip select input. Data may be written to the PGA2310 only when \overline{CS} is low. SDI is the serial data input pin. Control data is provided as a 16-bit word at the SDI pin, 8 bits each for the left and right channel

gain settings. Data is formatted as MSB first, straight binary code. SCLK is the serial clock input. Data is clocked into SDI on the rising edge of SCLK.

SDO is the serial data output pin, and is used when daisy-chaining multiple PGA2310 devices. Daisy-chain operation is described in detail later in this section. SDO is a tristate output, and assumes a high impedance state when \overline{CS} is high.

The protocol for the serial control port is shown in Figure 2. See Figure 3 for detailed timing specifications of the serial control port.

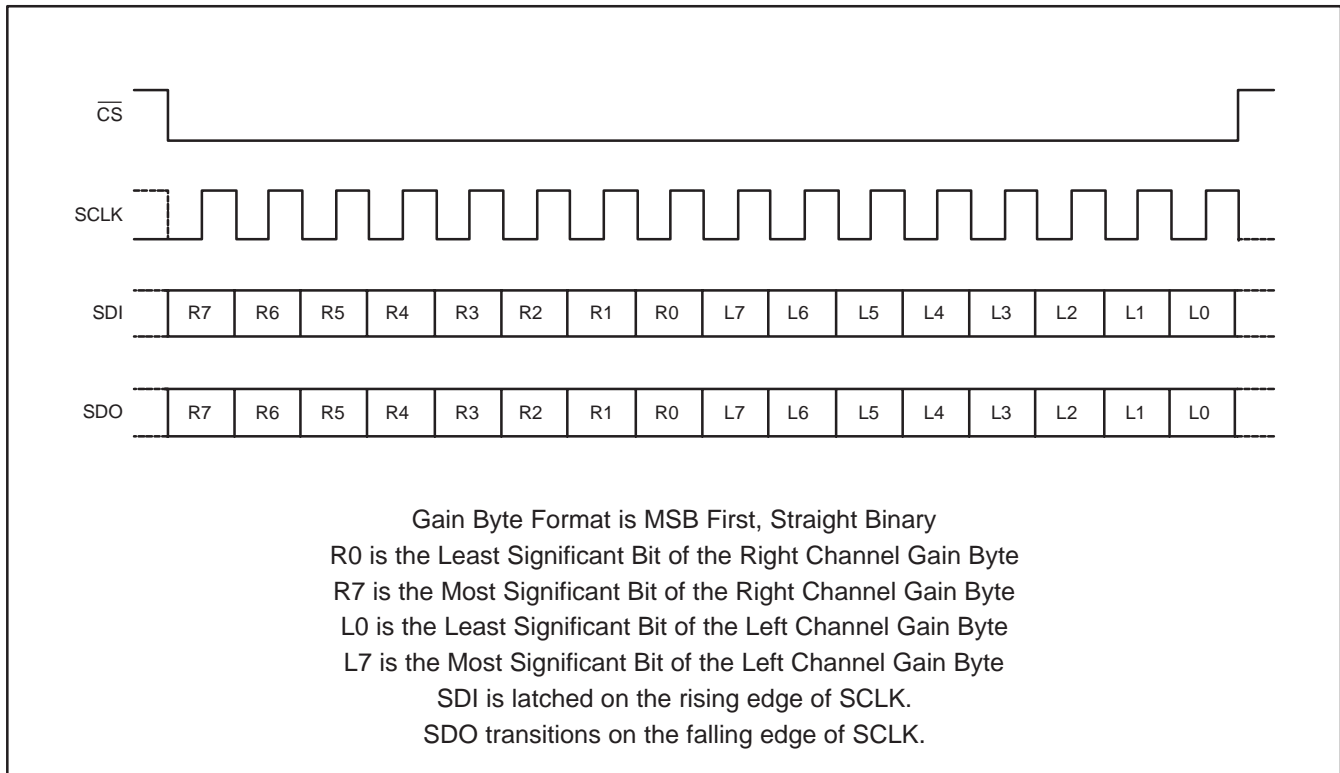

Figure 2. Serial Interface Protocol

GAIN SETTINGS

The gain for each channel is set by its corresponding 8-bit code, either R[7:0] or L[7:0], see Figure 2. The gain code data is straight binary format. If we let N equal the decimal equivalent of R[7:0] or L[7:0], then the following relationships exist for the gain settings:

For N = 0:

Mute Condition. The input multiplexer is connected to analog ground (AGNDR or AGNDL).

For N = 1 to 255:

$$\text{Gain (dB)} = 31.5 - [0.5 \cdot (255 - N)]$$

This results in a gain range of +31.5dB (with N = 255) to -95.5dB (with N = 1).

Changes in gain setting may be made with or without zero crossing detection. The operation of the zero crossing detector and timeout circuitry is discussed later in this data sheet.

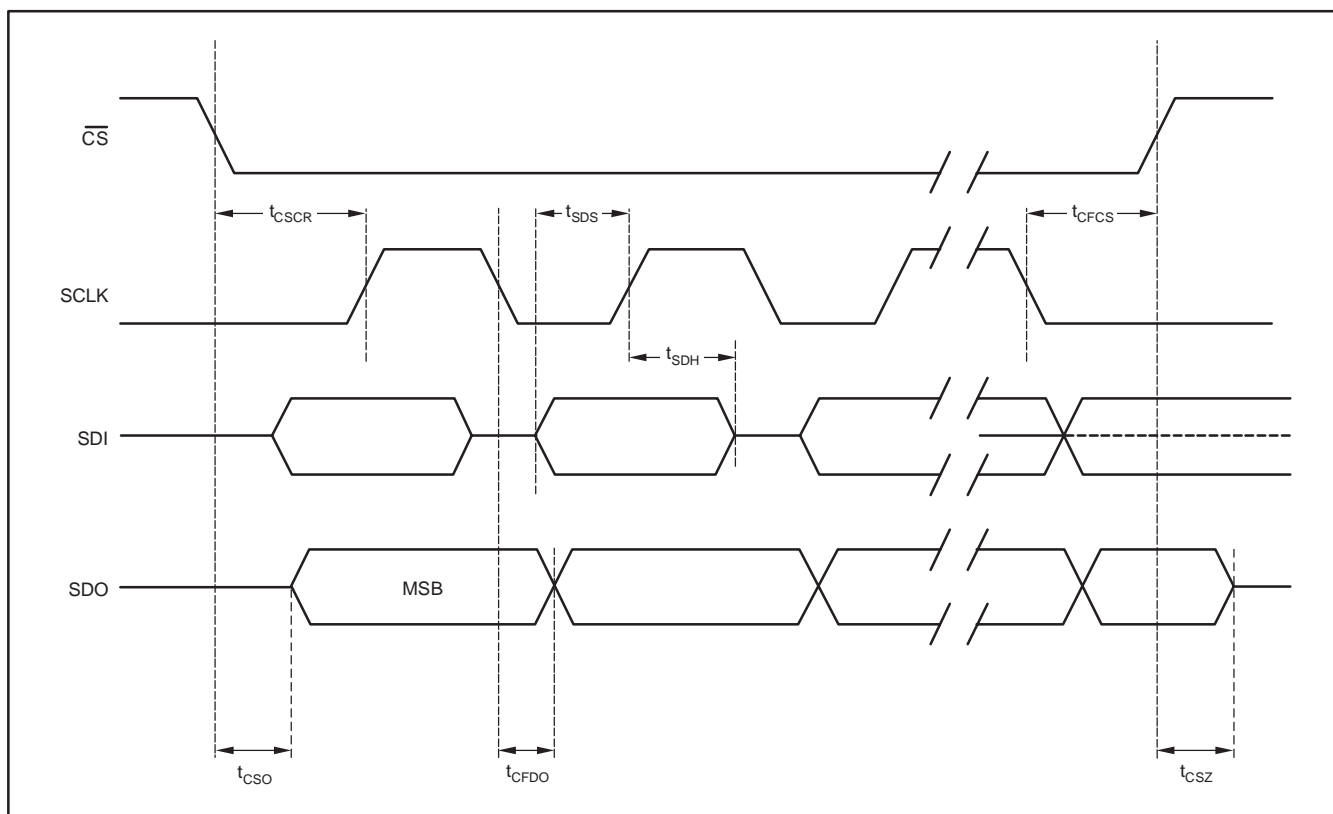

Figure 3. Serial Interface Timing Requirements

DAISY-CHAINING MULTIPLE PGA2310 DEVICES

In order to reduce the number of control signals required to support multiple PGA2310 devices on a printed circuit board, the serial control port supports daisy-chaining of multiple PGA2310 devices. Figure 4 shows the connection requirements for daisy-chain operation. This arrangement allows a three-wire serial interface to control many PGA2310 devices.

As shown in Figure 4, the SDO pin from device #1 is connected to the SDI input of device #2, and is repeated for additional devices. This in turn forms a large shift register, in which gain data may be written for all PGA2310s connected to the serial bus. The length of the shift register is $16 \times N$ bits, where N is equal to the number of PGA2310s connected to the serial bus. The length of the shift register is $16 \times N$ bits, where N is equal to the number of PGA2310 devices included in the chain. The \overline{CS} input must remain low for $16 \times N$ SCLK periods, where N is the number of devices connected in the chain, in order to allow enough SCLK cycles to load all devices.

ZERO CROSSING DETECTION

The PGA2310 includes a zero crossing detection function that can provide for noise-free level transitions. The concept is to change gain settings on a zero crossing of the input signal, thus minimizing audible glitches. This function is enabled or disabled using the ZCEN input (pin 1). When ZCEN is low, zero crossing detection is disabled. When ZCEN is high, zero crossing detection will be enabled.

The zero crossing detection takes effect with a change in gain setting for a corresponding channel. The new gain setting will not be latched until either two zero crossings are detected, or a timeout period of 16ms has elapsed without detecting two zero crossings. In the case of a timeout, the new gain setting takes effect with no attempt to minimize audible artifacts.

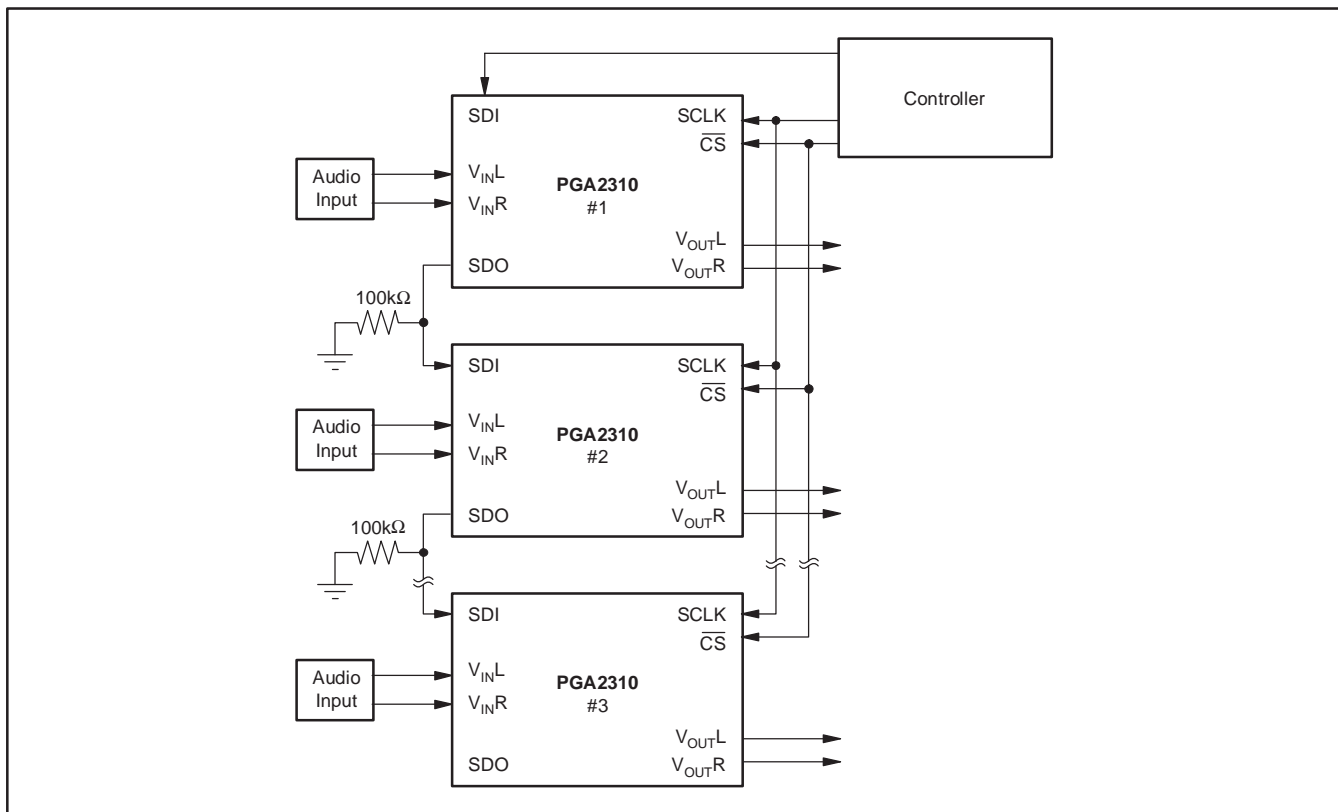

Figure 4. Daisy-Chaining Multiple PGA2310 Devices

PGA2310

SBOS207B – OCTOBER 2001 – REVISED JUNE 2004

PRINTED CIRCUIT BOARD LAYOUT GUIDELINES

It is recommended that the ground planes for the digital and analog sections of the printed circuit board (PCB) be separate from one another. The planes should be connected at a single point. Figure 6 shows the recommended PCB floor plan for the PGA2310.

The PGA2310 is mounted so that it straddles the split between the digital and analog ground planes. Pins 1 through 8 are oriented to the digital side of the board, while pins 9 through 16 are on the analog side of the board.

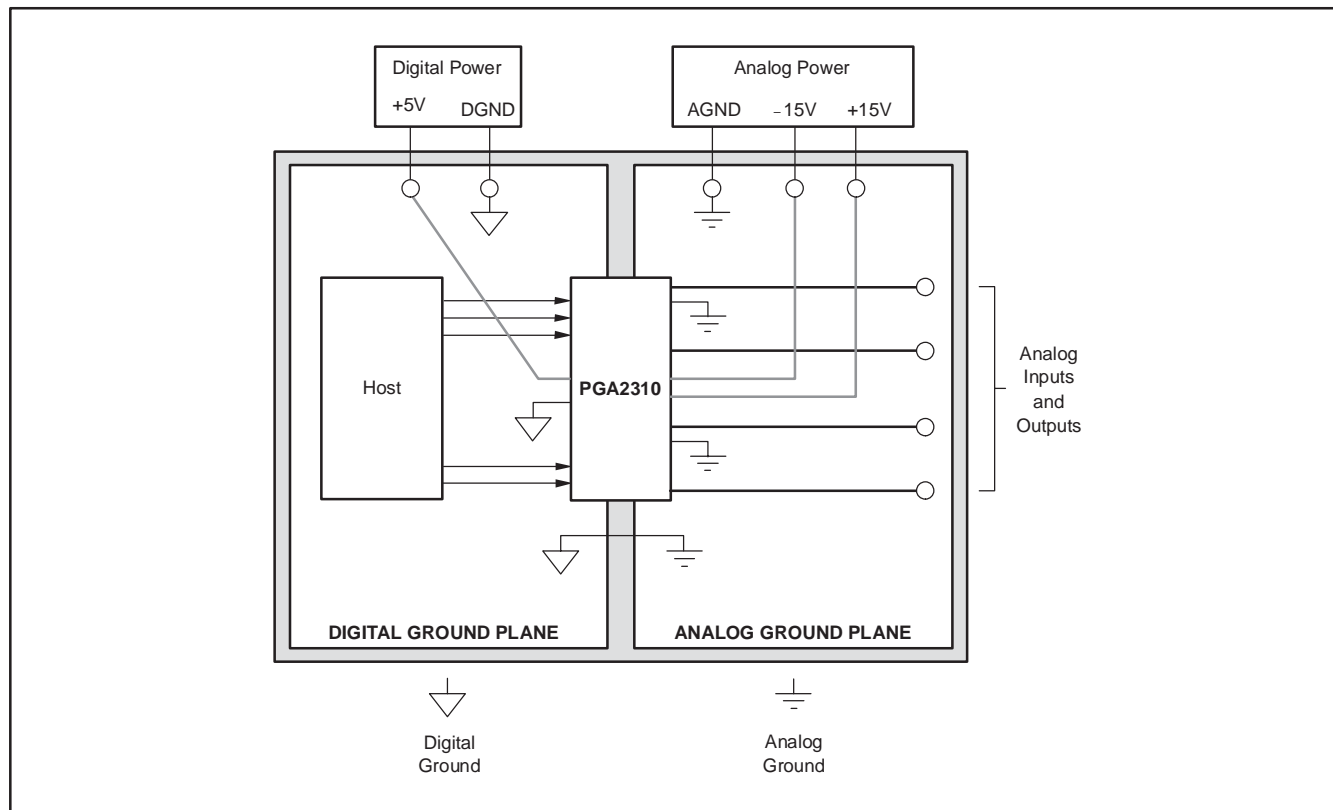

Figure 6. Typical PCB Layout Floor Plan

PACKAGING INFORMATION

Orderable Device	Status ⁽¹⁾	Package Type	Package Drawing	Pins	Package Qty	Eco Plan ⁽²⁾	Lead/Ball Finish	MSL Peak Temp ⁽³⁾
PGA2310PA	ACTIVE	PDIP	N	16	25	Green (RoHS & no Sb/Br)	CU NIPDAU	N / A for Pkg Type
PGA2310PAG4	ACTIVE	PDIP	N	16	25	Green (RoHS & no Sb/Br)	CU NIPDAU	N / A for Pkg Type
PGA2310UA	ACTIVE	SOIC	DW	16	40	Green (RoHS & no Sb/Br)	CU NIPDAU	Level-2-260C-1 YEAR
PGA2310UA/1K	ACTIVE	SOIC	DW	16	1000	Green (RoHS & no Sb/Br)	CU NIPDAU	Level-2-260C-1 YEAR
PGA2310UA/1KG4	ACTIVE	SOIC	DW	16	1000	Green (RoHS & no Sb/Br)	CU NIPDAU	Level-2-260C-1 YEAR
PGA2310UAG4	ACTIVE	SOIC	DW	16	40	Green (RoHS & no Sb/Br)	CU NIPDAU	Level-2-260C-1 YEAR

⁽¹⁾ The marketing status values are defined as follows:

ACTIVE: Product device recommended for new designs.

LIFEBUY: TI has announced that the device will be discontinued, and a lifetime-buy period is in effect.

NRND: Not recommended for new designs. Device is in production to support existing customers, but TI does not recommend using this part in a new design.

PREVIEW: Device has been announced but is not in production. Samples may or may not be available.

OBSOLETE: TI has discontinued the production of the device.

⁽²⁾ Eco Plan - The planned eco-friendly classification: Pb-Free (RoHS), Pb-Free (RoHS Exempt), or Green (RoHS & no Sb/Br) - please check <http://www.ti.com/productcontent> for the latest availability information and additional product content details.

TBD: The Pb-Free/Green conversion plan has not been defined.

Pb-Free (RoHS): TI's terms "Lead-Free" or "Pb-Free" mean semiconductor products that are compatible with the current RoHS requirements for all 6 substances, including the requirement that lead not exceed 0.1% by weight in homogeneous materials. Where designed to be soldered at high temperatures, TI Pb-Free products are suitable for use in specified lead-free processes.

Pb-Free (RoHS Exempt): This component has a RoHS exemption for either 1) lead-based flip-chip solder bumps used between the die and package, or 2) lead-based die adhesive used between the die and leadframe. The component is otherwise considered Pb-Free (RoHS compatible) as defined above.

Green (RoHS & no Sb/Br): TI defines "Green" to mean Pb-Free (RoHS compatible), and free of Bromine (Br) and Antimony (Sb) based flame retardants (Br or Sb do not exceed 0.1% by weight in homogeneous material)

⁽³⁾ MSL, Peak Temp. -- The Moisture Sensitivity Level rating according to the JEDEC industry standard classifications, and peak solder temperature.

Important Information and Disclaimer: The information provided on this page represents TI's knowledge and belief as of the date that it is provided. TI bases its knowledge and belief on information provided by third parties, and makes no representation or warranty as to the accuracy of such information. Efforts are underway to better integrate information from third parties. TI has taken and continues to take reasonable steps to provide representative and accurate information but may not have conducted destructive testing or chemical analysis on incoming materials and chemicals. TI and TI suppliers consider certain information to be proprietary, and thus CAS numbers and other limited information may not be available for release.

In no event shall TI's liability arising out of such information exceed the total purchase price of the TI part(s) at issue in this document sold by TI to Customer on an annual basis.

TAPE AND REEL INFORMATION

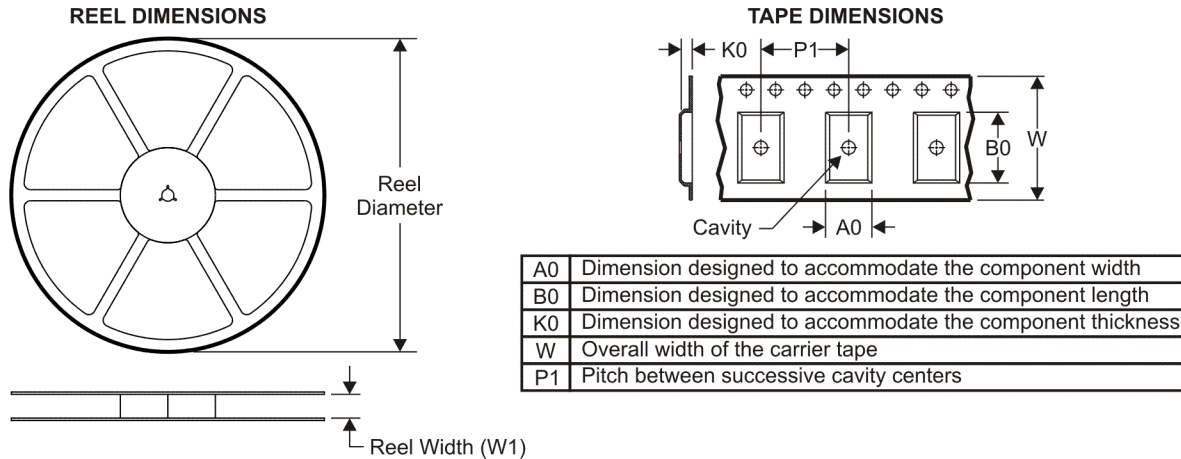

QUADRANT ASSIGNMENTS FOR PIN 1 ORIENTATION IN TAPE



*All dimensions are nominal

Device	Package Type	Package Drawing	Pins	SPQ	Reel Diameter (mm)	Reel Width W1 (mm)	A0 (mm)	B0 (mm)	K0 (mm)	P1 (mm)	W (mm)	Pin1 Quadrant
PGA2310UA/1K	SOIC	DW	16	1000	330.0	16.4	10.85	10.8	2.7	12.0	16.0	Q1

TAPE AND REEL BOX DIMENSIONS



*All dimensions are nominal

Device	Package Type	Package Drawing	Pins	SPQ	Length (mm)	Width (mm)	Height (mm)
PGA2310UA/1K	SOIC	DW	16	1000	346.0	346.0	33.0

DW (R-PDSO-G16)

PLASTIC SMALL-OUTLINE PACKAGE

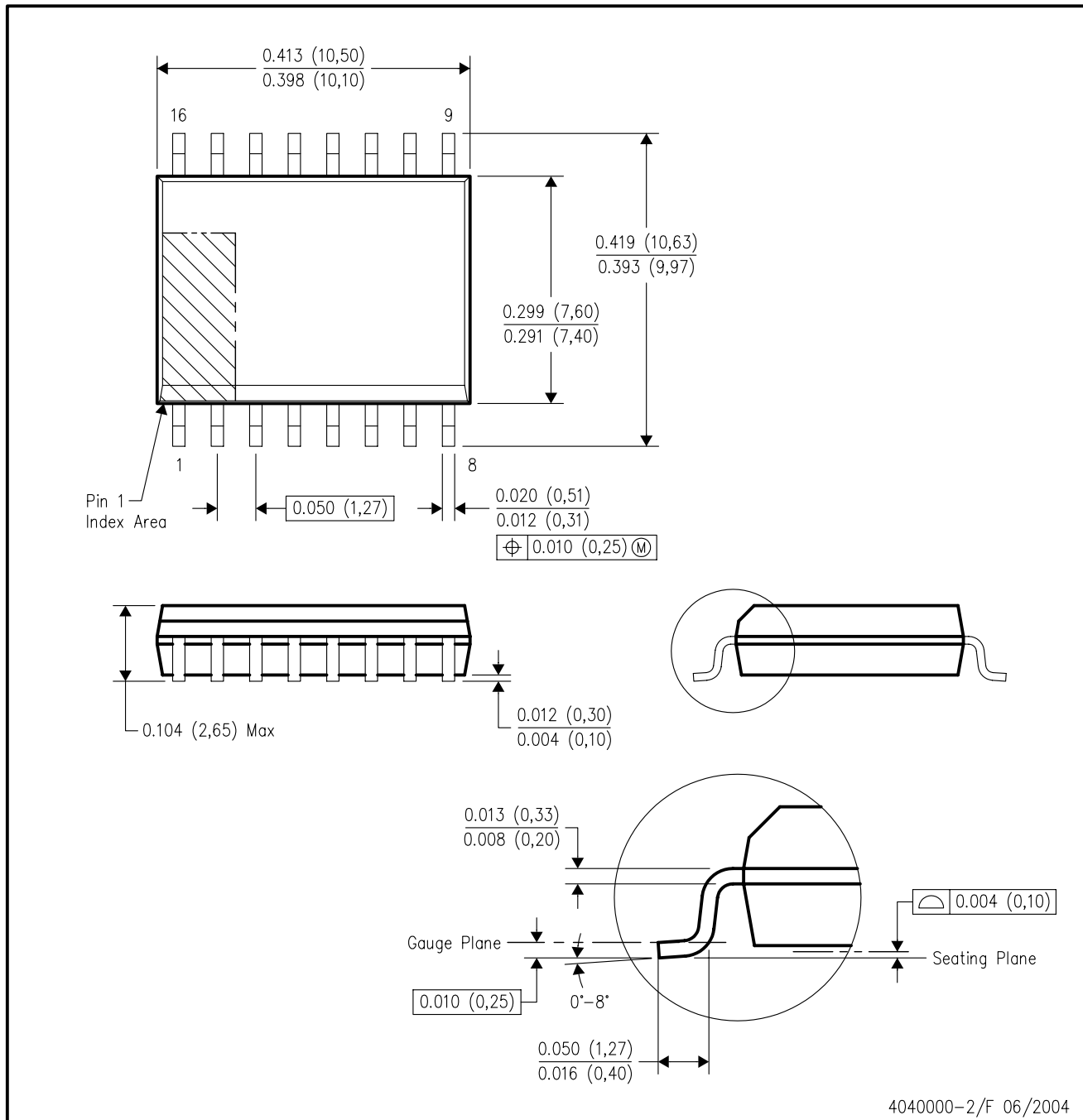

4040000-2/F 06/2004

- NOTES:
- A. All linear dimensions are in inches (millimeters).
 - B. This drawing is subject to change without notice.
 - C. Body dimensions do not include mold flash or protrusion not to exceed 0.006 (0,15).
 - D. Falls within JEDEC MS-013 variation AA.

IMPORTANT NOTICE

Texas Instruments Incorporated and its subsidiaries (TI) reserve the right to make corrections, modifications, enhancements, improvements, and other changes to its products and services at any time and to discontinue any product or service without notice. Customers should obtain the latest relevant information before placing orders and should verify that such information is current and complete. All products are sold subject to TI's terms and conditions of sale supplied at the time of order acknowledgment.

TI warrants performance of its hardware products to the specifications applicable at the time of sale in accordance with TI's standard warranty. Testing and other quality control techniques are used to the extent TI deems necessary to support this warranty. Except where mandated by government requirements, testing of all parameters of each product is not necessarily performed.

TI assumes no liability for applications assistance or customer product design. Customers are responsible for their products and applications using TI components. To minimize the risks associated with customer products and applications, customers should provide adequate design and operating safeguards.

TI does not warrant or represent that any license, either express or implied, is granted under any TI patent right, copyright, mask work right, or other TI intellectual property right relating to any combination, machine, or process in which TI products or services are used. Information published by TI regarding third-party products or services does not constitute a license from TI to use such products or services or a warranty or endorsement thereof. Use of such information may require a license from a third party under the patents or other intellectual property of the third party, or a license from TI under the patents or other intellectual property of TI.

Reproduction of TI information in TI data books or data sheets is permissible only if reproduction is without alteration and is accompanied by all associated warranties, conditions, limitations, and notices. Reproduction of this information with alteration is an unfair and deceptive business practice. TI is not responsible or liable for such altered documentation. Information of third parties may be subject to additional restrictions.

Resale of TI products or services with statements different from or beyond the parameters stated by TI for that product or service voids all express and any implied warranties for the associated TI product or service and is an unfair and deceptive business practice. TI is not responsible or liable for any such statements.

TI products are not authorized for use in safety-critical applications (such as life support) where a failure of the TI product would reasonably be expected to cause severe personal injury or death, unless officers of the parties have executed an agreement specifically governing such use. Buyers represent that they have all necessary expertise in the safety and regulatory ramifications of their applications, and acknowledge and agree that they are solely responsible for all legal, regulatory and safety-related requirements concerning their products and any use of TI products in such safety-critical applications, notwithstanding any applications-related information or support that may be provided by TI. Further, Buyers must fully indemnify TI and its representatives against any damages arising out of the use of TI products in such safety-critical applications.

TI products are neither designed nor intended for use in military/aerospace applications or environments unless the TI products are specifically designated by TI as military-grade or "enhanced plastic." Only products designated by TI as military-grade meet military specifications. Buyers acknowledge and agree that any such use of TI products which TI has not designated as military-grade is solely at the Buyer's risk, and that they are solely responsible for compliance with all legal and regulatory requirements in connection with such use.

TI products are neither designed nor intended for use in automotive applications or environments unless the specific TI products are designated by TI as compliant with ISO/TS 16949 requirements. Buyers acknowledge and agree that, if they use any non-designated products in automotive applications, TI will not be responsible for any failure to meet such requirements.

Following are URLs where you can obtain information on other Texas Instruments products and application solutions:

Products

Amplifiers	amplifier.ti.com
Data Converters	dataconverter.ti.com
DLP® Products	www.dlp.com
DSP	dsp.ti.com
Clocks and Timers	www.ti.com/clocks
Interface	interface.ti.com
Logic	logic.ti.com
Power Mgmt	power.ti.com
Microcontrollers	microcontroller.ti.com
RFID	www.ti-rfid.com
RF/IF and ZigBee® Solutions	www.ti.com/lprf

Applications

Audio	www.ti.com/audio
Automotive	www.ti.com/automotive
Broadband	www.ti.com/broadband
Digital Control	www.ti.com/digitalcontrol
Medical	www.ti.com/medical
Military	www.ti.com/military
Optical Networking	www.ti.com/opticalnetwork
Security	www.ti.com/security
Telephony	www.ti.com/telephony
Video & Imaging	www.ti.com/video
Wireless	www.ti.com/wireless

Mailing Address: Texas Instruments, Post Office Box 655303, Dallas, Texas 75265
Copyright © 2009, Texas Instruments Incorporated