

- Single Device 9A Output
- Input Voltage Range: 3.1V to 6.0V
- Adjustable Output Voltage
- 90% Efficiency
- Remote Sense Capability
- Standby Function
- Over-Temperature Protection

In-line Package) Integrated Switching Regulators (ISRs), designed for stand-alone operation in applications requiring as much as 9A of output current.

The PT6600 series will operate off either a 3.3V or 5V input bus and requires only two external capacitors for proper operation. Please note that this product does not include short circuit protection.

The PT6600 series is a high performance family of 14-Pin SIP (Single

Standard Application

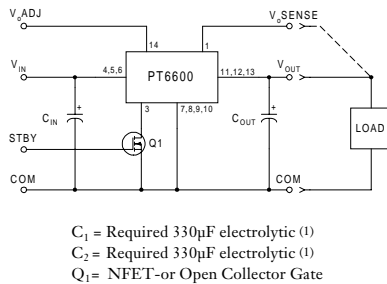

Pin-Out Information

Pin	Function
1	Remote Sense
2	Do not connect
3	STBY*-Standby
4	V _{in}
5	V _{in}
6	V _{in}
7	GND
8	GND
9	GND
10	GND
11	V _{out}
12	V _{out}
13	V _{out}
14	V _{out} Adjust

Ordering Information

PT6601!	= +3.3 Volts
†PT6602!	= +1.5 Volts
PT6603!	= +2.5 Volts
PT6604!	= +3.6 Volts
†PT6605!	= +1.2 Volts
†PT6606!	= +1.8 Volts

†3.3V Input Bus Capable

PT Series Suffix (PT1234X)

Case/Pin Configuration	Heat Spreader	Heat Spreader with Side Tabs
Vertical Through-Hole	P	R
Horizontal Through-Hole	D	G
Horizontal Surface Mount	E	B

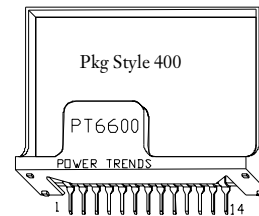

Note: Back surface of product is conducting metal.

Specifications

Characteristics (T _a = 25°C unless noted)	Symbols	Conditions	PT6600 SERIES			Units
			Min	Typ	Max	
Output Current	I _o	T _a = 60°C, 200 LFM, pkg P T _a = 25°C, natural convection	0.1 (2) 0.1 (2)	—	9.0 (4) 7.0 (4)	A
Input Voltage Range	V _{in}	0.1A ≤ I _o ≤ 8.0A	V _o = +2.5/3.3V 4.5 3.1 4.8	—	6.0 6.0 6.0	V
Output Voltage Tolerance	ΔV _o	V _{in} = +5V, I _o = 8.0A T _a = 0°C to 65°C	V _o -0.1	—	V _o +0.1	V
Output Voltage Adjust Range	V _{oadj}	Pin 14 to V _o or ground V _{in} min = +3.1V or V _o +1.2V (whichever is greater)	V _o = +3.3V 2.25 V _o = +1.5V 1.27 V _o = +2.5V 1.80 V _o = +3.6V 2.50	—	4.20 2.65 3.50 4.30	V
Line Regulation	Reg _{line}	4.5V ≤ V _{in} ≤ 6.0V, I _o = 8.0A 3.1V ≤ V _{in} ≤ 6.0V, I _o = 8.0A 4.5V ≤ V _{in} ≤ 6.0V, I _o = 8.0A	V _o = +3.3V — V _o = +1.5V — V _o = +2.5V —	±7 ±3 ±7	±17 ±8 ±13	mV
Load Regulation	Reg _{load}	V _{in} = +5V, 0.1 ≤ I _o ≤ 8.0A	V _o = +3.3V — V _o = +1.5V — V _o = +2.5V —	±17 ±12 ±13	±33 ±23 ±25	mV
V _o Ripple/Noise	V _n	V _{in} = 5V, I _o = 8.0A	—	50	—	mV _{pp}
Transient Response with C ₂ = 330µF	t _{tr} V _{os}	I _o step between 4.0A and 8.0A V _o over/undershoot	—	100 150	—	µSec mV
Efficiency	η	V _{in} = +5V, I _o = 3.0A V _{in} = +5V, I _o = 8.0A	V _o = +3.3/3.6V — V _o = +1.5V — V _o = +2.5V —	90 76 85	—	%
Switching Frequency	f _o	3.1V ≤ V _{in} ≤ 6.0V 0.1A ≤ I _o ≤ 8.0A	—	475 600 725	—	kHz
Absolute Maximum Operating Temperature Range	T _a	Over V _{in} range	-40 (3)	—	+85 (4)	°C
Thermal Resistance	θ _{ja}	Free Air Convection (40-60 LFM)	—	25	—	°C/W

Continued

PT6600 Series

9 Amp 5V/3.3V Input Adjustable Integrated Switching Regulator

Specifications (continued)

Characteristics (T _a = 25°C unless noted)	Symbols	Conditions	PT6600 SERIES			Units
			Min	Typ	Max	
Storage Temperature	T _s	—	-40	—	+125	°C
Mechanical Shock	—	Per Mil-STD-883D, Method 2002.3	—	500	—	G's
Mechanical Vibration	—	Per Mil-STD-883D, Method 2007.2, 20-2000 Hz, soldered in a PC board	—	7.5	—	G's
Weight	—	—	—	14	—	grams

- Notes: (1) The PT6600 series requires two 330µF electrolytic capacitors (input and output) for proper operation in all applications. The input capacitance must be rated for a minimum of 1.1Arms of ripple current. See the application note, PT6500/6600 Series Capacitor Recommendations.
 (2) ISR will operate down to no load with reduced specifications.
 (3) For operation below 0°C, use tantalum capacitors for C_{IN} and C_{OUT}. For more information, contact an Application Specialist.
 (4) See Safe Operating Curves, or contact the factory for the appropriate derating.

TYPICAL CHARACTERISTICS

Safe Operating Area Curves (@ V_{in}=+5.0V) (See Note B)

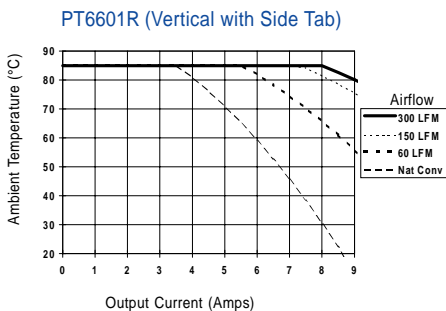
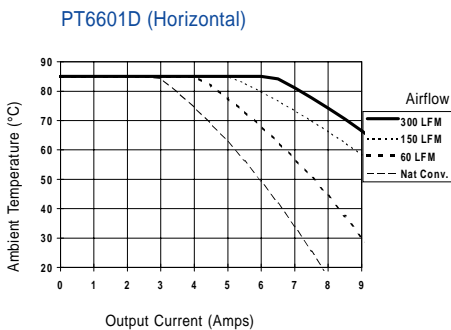
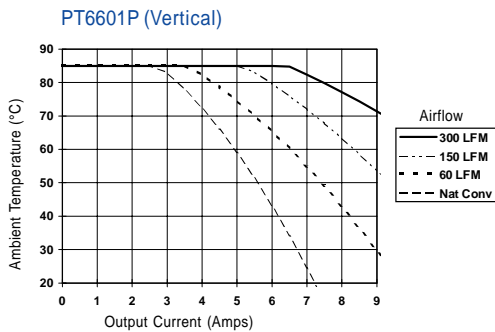

PT6601, 3.3 VDC (See Note A)

Efficiency vs Output Current

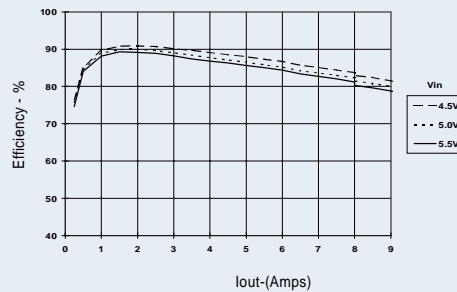

Ripple vs Output Current

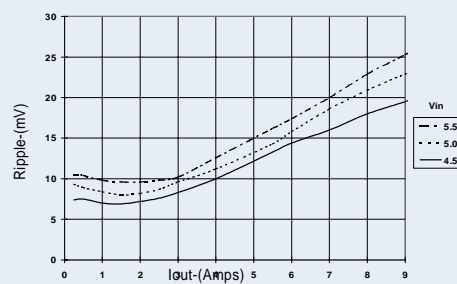

Power Dissipation vs Output Current

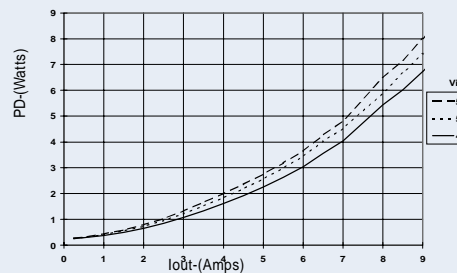

Note A: All data listed in the above graphs has been developed from actual products tested at 25°C. This data is considered typical data for the ISR.

Note B: SOA curves represent operating conditions at which internal components are at or below manufacturer's maximum rated operating temperatures.

PT6600 Series

Table 2

PT6600 ADJUSTMENT RESISTOR VALUES								
Series Pt #	PT6605	PT6607	PT6602	PT6608	PT6606	PT6603	PT6601	PT6604
V_O (nom)	1.2	1.3	1.5	1.7	1.8	2.5	3.3	3.6
V_a (req'd)								
1.15	(5.5)k Ω							
1.2		(3.0)k Ω						
1.25	47.8k Ω	(10.5)k Ω						
1.3	22.9k Ω		(1.7)k Ω					
1.35	14.6k Ω	47.8k Ω	(3.8)k Ω					
1.4	10.5k Ω	22.9k Ω	(8.0)k Ω	(1.3)k Ω	(0.5)k Ω			
1.45	8.0k Ω	14.6k Ω	(20.4)k Ω	(2.5)k Ω	(1.2)k Ω			
1.5	6.3k Ω	10.5k Ω		(4.2)k Ω	(2.2)k Ω			
1.55	5.1k Ω	8.0k Ω	47.8k Ω	(7.1)k Ω	(3.5)k Ω			
1.6	4.2k Ω	6.3k Ω	22.9k Ω	(12.9)k Ω	(5.5)k Ω			
1.65	3.5k Ω	4.1k Ω	14.6k Ω	(30.4)k Ω	(8.8)k Ω			
1.7	3.0k Ω	4.2k Ω	10.5k Ω		(15.4)k Ω			
1.75	2.5k Ω	3.5k Ω	8.0k Ω	47.8k Ω	(35.4)k Ω			
1.8	2.2k Ω	3.0k Ω	6.3k Ω	22.9k Ω		(1.5)k Ω		
1.85	1.8k Ω	2.5k Ω	5.1k Ω	14.6k Ω	47.8k Ω	(2.3)k Ω		
1.9	1.6k Ω	2.2k Ω	4.2k Ω	10.5k Ω	22.9k Ω	(3.3)k Ω		
1.95	1.3k Ω	1.8k Ω	3.5k Ω	8.0k Ω	14.6k Ω	(4.4)k Ω		
2.0	1.1k Ω	1.6k Ω	3.0k Ω	6.3k Ω	10.5k Ω	(5.8)k Ω		
2.05	0.9k Ω	1.3k Ω	2.5k Ω	5.1k Ω	8.0k Ω	(7.4)k Ω		
2.1	0.8k Ω	1.1k Ω	2.2k Ω	4.2k Ω	6.3k Ω	(9.5)k Ω		
2.15	0.6k Ω	0.9k Ω	1.8k Ω	3.5k Ω	5.1k Ω	(12.2)k Ω		
2.2	0.5k Ω	0.8k Ω	1.6k Ω	3.0k Ω	4.2k Ω	(15.7)k Ω		
2.25	0.4k Ω	0.6k Ω	1.3k Ω	2.5k Ω	3.5k Ω	(20.7)k Ω	(2.3)k Ω	
2.3	0.3k Ω	0.5k Ω	1.1k Ω	2.2k Ω	3.0k Ω	(28.2)k Ω	(3.6)k Ω	
2.35	0.2k Ω	0.4k Ω	0.9k Ω	1.8k Ω	2.5k Ω	(40.7)k Ω	(5.1)k Ω	
2.4		0.3k Ω	0.8k Ω	1.6k Ω	2.2k Ω	(65.6)k Ω	(6.7)k Ω	
2.45		0.2k Ω	0.6k Ω	1.3k Ω	1.8k Ω	(140.0)k Ω	(8.5)k Ω	
2.5			0.5k Ω	1.1k Ω	1.6k Ω		(10.6)k Ω	(1.5)k Ω
2.55			0.4k Ω	0.9k Ω	1.3k Ω	95.6k Ω	(12.9)k Ω	(2.7)k Ω
2.6			0.3k Ω	0.8k Ω	1.1k Ω	45.7k Ω	(15.6)k Ω	(3.9)k Ω
2.65			0.2k Ω	0.6k Ω	6.9k Ω	29.0k Ω	(18.6)k Ω	(5.3)k Ω
2.7				0.5k Ω	0.8k Ω	20.7k Ω	(22.2)k Ω	(6.8)k Ω
2.75				0.4k Ω	0.6k Ω	15.7k Ω	(26.4)k Ω	(8.5)k Ω
2.8				0.3k Ω	0.5k Ω	12.4k Ω	(31.5)k Ω	(10.4)k Ω
2.85				0.2k Ω	0.4k Ω	10.0k Ω	(37.6)k Ω	(12.6)k Ω
2.9					0.3k Ω	8.3k Ω	(45.4)k Ω	(15.0)k Ω
2.95					0.2k Ω	0.9k Ω	(55.3)k Ω	(17.9)k Ω
3.0						5.8k Ω	(68.6)k Ω	(21.2)k Ω
3.1						4.1k Ω	(115.0)k Ω	(29.9)k Ω
3.2						2.9k Ω	(254.0)k Ω	(42.9)k Ω
3.3						2.0k Ω		(64.6)k Ω
3.4						1.3k Ω	109.0k Ω	(108.0)k Ω
3.5						0.8k Ω	48.4k Ω	(238.0)k Ω
3.6							28.2k Ω	
3.7							18.2k Ω	87.9k Ω
3.8							12.1k Ω	37.9k Ω
3.9	4/. $V_{OUT} > 3.8Vdc$ requires $V_{IN} > 5.0Vdc$!						8.1k Ω	21.2k Ω
4.0							5.2k Ω	12.9k Ω
4.1							3.0k Ω	7.9k Ω
4.2							1.3k Ω	4.6k Ω
4.3								2.2k Ω

R1 = (Blue) R2 = Black

PT6600 Series

Using the Standby Function on the PT6600 5V Bus Converters

For applications requiring output voltage On/Off control, the 14-pin PT6600 ISR series incorporates a standby function. This function may be used in applications that require power-up/shutdown sequencing, and wherever there is a requirement for the output status of the module to be controlled by external circuitry.

The standby function is provided by the *STBY** control, pin 3. If pin 3 is left open-circuit the regulator operates normally, and provides a regulated output when a valid supply voltage is applied to V_{in} (pins 4, 5, & 6) with respect to GND (pins 7-10). If a low voltage² is then applied to pin-3 the regulator output will be disabled and the input current drawn by the ISR will drop to less than 50mA⁴. The standby control may also be used to hold-off the regulator output during the period that input power is applied.

The standby control pin is ideally controlled using an open-collector (or open-drain) discrete transistor (See Figure 1). It may also be driven directly from a dedicated TTL³ compatible gate. Table 1 provides details of the threshold requirements.

Table 1 Inhibit Control Thresholds ^(2,3)

Parameter	Min	Max
Enable (V_{IH})	1V	5V
Disable (V_{IL})	-0.1V	0.35V

Notes:

- The Standby/Inhibit control logic is similar for all Power Trends' modules, but the flexibility and threshold tolerances will be different. For specific information on this function for other regulator models, consult the applicable application note.
- The Standby control pin is ideally controlled using an open-collector (or open-drain) discrete transistor and requires no external pull-up resistor. The control input has an open-circuit voltage of about 1Vdc. To disable the regulator output, the control pin must be pulled to less than 0.35Vdc with a low-level 0.5mA sink to ground.
- The Standby input on the PT6600 series may be driven by a differential output device, making it compatible with TTL logic. A standard TTL logic gate will meet the 0.35V $V_{IL(max)}$ requirement (Table 1) at 0.5mA I_{OL} . *Do not* use devices that can drive the Standby control input above 5Vdc.
- When the regulator output is disabled the current drawn from the input source is reduced to approximately 30–40mA (50mA maximum).

Figure 1

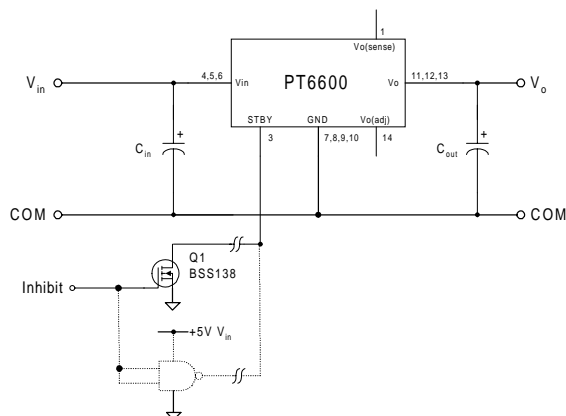

Turn-On Time: In the circuit of Figure 1, turning Q_1 on applies a low voltage to the Standby control (pin 3) and disables the regulator output. Correspondingly, turning Q_1 off releases the low-voltage signal and enables the output. The PT6600 ISR series regulators have a fast response and will provide a fully regulated output voltage within 250 μ sec. The actual turn-on time will vary with load and the total amount of output capacitance. The waveform of Figure 2 shows the typical output voltage response of a PT6601 (3.3V) following the turn-off of Q_1 at time $t = 0.0$ secs. The waveform was measured with a 5Vdc input voltage, and 0.6 Ω load.

Figure 2

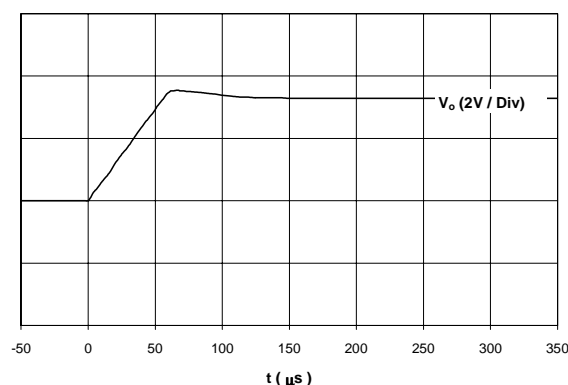

PACKAGING INFORMATION

Orderable Device	Status ⁽¹⁾	Package Type	Package Drawing	Pins	Package Qty	Eco Plan ⁽²⁾	Lead/Ball Finish	MSL Peak Temp ⁽³⁾
PT6601B	NRND	SIP MOD ULE	EEK	14	12	Pb-Free (RoHS)	Call TI	Level-1-215C-UNLIM
PT6601D	NRND	SIP MOD ULE	EEA	14	12	Pb-Free (RoHS)	Call TI	N / A for Pkg Type
PT6601E	NRND	SIP MOD ULE	EEC	14	12	Pb-Free (RoHS)	Call TI	Level-1-215C-UNLIM
PT6601ET	NRND	SIP MOD ULE	EEC	14		TBD	Call TI	Call TI
PT6601F	NRND	SIP MOD ULE	EEF	14		TBD	Call TI	Call TI
PT6601G	NRND	SIP MOD ULE	EEG	14	12	Pb-Free (RoHS)	Call TI	N / A for Pkg Type
PT6601L	NRND	SIP MOD ULE	EEL	14		TBD	Call TI	Call TI
PT6601M	NRND	SIP MOD ULE	EEM	14		TBD	Call TI	Call TI
PT6601P	NRND	SIP MOD ULE	EED	14	12	Pb-Free (RoHS)	Call TI	N / A for Pkg Type
PT6601Q	NRND	SIP MOD ULE	EEQ	14		TBD	Call TI	Call TI
PT6601S	NRND	SIP MOD ULE	EES	14		TBD	Call TI	Call TI
PT6602B	NRND	SIP MOD ULE	EEK	14	12	Pb-Free (RoHS)	Call TI	Level-1-215C-UNLIM
PT6602D	NRND	SIP MOD ULE	EEA	14	12	Pb-Free (RoHS)	Call TI	N / A for Pkg Type
PT6602E	NRND	SIP MOD ULE	EEC	14	12	Pb-Free (RoHS)	Call TI	Level-1-215C-UNLIM
PT6602F	NRND	SIP MOD ULE	EEF	14		TBD	Call TI	Call TI
PT6602G	NRND	SIP MOD ULE	EEG	14		TBD	Call TI	Call TI
PT6602L	NRND	SIP MOD ULE	EEL	14		TBD	Call TI	Call TI
PT6602M	NRND	SIP MOD ULE	EEM	14		TBD	Call TI	Call TI
PT6602P	NRND	SIP MOD ULE	EED	14	12	Pb-Free (RoHS)	Call TI	N / A for Pkg Type
PT6602Q	NRND	SIP MOD ULE	EEQ	14		TBD	Call TI	Call TI
PT6602R	NRND	SIP MOD ULE	EEE	14		TBD	Call TI	Call TI
PT6603B	NRND	SIP MOD ULE	EEK	14	12	Pb-Free (RoHS)	Call TI	Level-1-215C-UNLIM
PT6603D	NRND	SIP MOD ULE	EEA	14	12	Pb-Free (RoHS)	Call TI	N / A for Pkg Type
PT6603E	NRND	SIP MOD ULE	EEC	14	12	Pb-Free (RoHS)	Call TI	Level-1-215C-UNLIM
PT6603F	NRND	SIP MOD ULE	EEF	14		TBD	Call TI	Call TI

Orderable Device	Status ⁽¹⁾	Package Type	Package Drawing	Pins	Package Qty	Eco Plan ⁽²⁾	Lead/Ball Finish	MSL Peak Temp ⁽³⁾
PT6603L	NRND	SIP MOD ULE	EEL	14	12	Pb-Free (RoHS)	Call TI	Level-1-215C-UNLIM
PT6603M	NRND	SIP MOD ULE	EEM	14	12	Pb-Free (RoHS)	Call TI	N / A for Pkg Type
PT6603P	NRND	SIP MOD ULE	EED	14	12	Pb-Free (RoHS)	Call TI	N / A for Pkg Type
PT6603Q	NRND	SIP MOD ULE	EEQ	14		TBD	Call TI	Call TI
PT6603R	NRND	SIP MOD ULE	EEE	14	12	Pb-Free (RoHS)	Call TI	N / A for Pkg Type
PT6603S	NRND	SIP MOD ULE	EES	14		TBD	Call TI	Call TI
PT6604B	NRND	SIP MOD ULE	EEK	14		TBD	Call TI	Call TI
PT6604D	NRND	SIP MOD ULE	EEA	14		TBD	Call TI	Call TI
PT6604E	NRND	SIP MOD ULE	EEC	14		TBD	Call TI	Call TI
PT6604F	NRND	SIP MOD ULE	EEF	14		TBD	Call TI	Call TI
PT6604G	NRND	SIP MOD ULE	EEG	14		TBD	Call TI	Call TI
PT6604L	NRND	SIP MOD ULE	EEL	14		TBD	Call TI	Call TI
PT6604M	NRND	SIP MOD ULE	EEM	14		TBD	Call TI	Call TI
PT6604P	NRND	SIP MOD ULE	EED	14		TBD	Call TI	Call TI
PT6604Q	NRND	SIP MOD ULE	EEQ	14		TBD	Call TI	Call TI
PT6604R	NRND	SIP MOD ULE	EEE	14		TBD	Call TI	Call TI
PT6605B	NRND	SIP MOD ULE	EEK	14	12	Pb-Free (RoHS)	Call TI	Level-1-215C-UNLIM
PT6605E	NRND	SIP MOD ULE	EEC	14		TBD	Call TI	Call TI
PT6605ET	OBSOLETE	SIP MOD ULE	EEC	14		TBD	Call TI	Call TI
PT6605F	NRND	SIP MOD ULE	EEF	14		TBD	Call TI	Call TI
PT6605G	NRND	SIP MOD ULE	EEG	14		TBD	Call TI	Call TI
PT6605L	NRND	SIP MOD ULE	EEL	14		TBD	Call TI	Call TI
PT6605M	NRND	SIP MOD ULE	EEM	14		TBD	Call TI	Call TI
PT6605Q	NRND	SIP MOD ULE	EEQ	14		TBD	Call TI	Call TI
PT6605R	NRND	SIP MOD ULE	EEE	14		TBD	Call TI	Call TI
PT6606B	NRND	SIP MOD ULE	EEK	14	12	Pb-Free (RoHS)	Call TI	Level-1-215C-UNLIM

Orderable Device	Status ⁽¹⁾	Package Type	Package Drawing	Pins	Package Qty	Eco Plan ⁽²⁾	Lead/Ball Finish	MSL Peak Temp ⁽³⁾
PT6606E	NRND	SIP MOD ULE	EEC	14	12	Pb-Free (RoHS)	Call TI	Level-1-215C-UNLIM
PT6606F	NRND	SIP MOD ULE	EEF	14		TBD	Call TI	Call TI
PT6606G	NRND	SIP MOD ULE	EEG	14	12	Pb-Free (RoHS)	Call TI	N / A for Pkg Type
PT6606L	NRND	SIP MOD ULE	EEL	14		TBD	Call TI	Call TI
PT6606M	NRND	SIP MOD ULE	EEM	14		TBD	Call TI	Call TI
PT6606P	NRND	SIP MOD ULE	EED	14	12	Pb-Free (RoHS)	Call TI	N / A for Pkg Type
PT6606Q	NRND	SIP MOD ULE	EEQ	14		TBD	Call TI	Call TI
PT6606R	NRND	SIP MOD ULE	EEE	14	12	Pb-Free (RoHS)	Call TI	N / A for Pkg Type

⁽¹⁾ The marketing status values are defined as follows:

ACTIVE: Product device recommended for new designs.

LIFEBUY: TI has announced that the device will be discontinued, and a lifetime-buy period is in effect.

NRND: Not recommended for new designs. Device is in production to support existing customers, but TI does not recommend using this part in a new design.

PREVIEW: Device has been announced but is not in production. Samples may or may not be available.

OBSOLETE: TI has discontinued the production of the device.

⁽²⁾ Eco Plan - The planned eco-friendly classification: Pb-Free (RoHS), Pb-Free (RoHS Exempt), or Green (RoHS & no Sb/Br) - please check <http://www.ti.com/productcontent> for the latest availability information and additional product content details.

TBD: The Pb-Free/Green conversion plan has not been defined.

Pb-Free (RoHS): TI's terms "Lead-Free" or "Pb-Free" mean semiconductor products that are compatible with the current RoHS requirements for all 6 substances, including the requirement that lead not exceed 0.1% by weight in homogeneous materials. Where designed to be soldered at high temperatures, TI Pb-Free products are suitable for use in specified lead-free processes.

Pb-Free (RoHS Exempt): This component has a RoHS exemption for either 1) lead-based flip-chip solder bumps used between the die and package, or 2) lead-based die adhesive used between the die and leadframe. The component is otherwise considered Pb-Free (RoHS compatible) as defined above.

Green (RoHS & no Sb/Br): TI defines "Green" to mean Pb-Free (RoHS compatible), and free of Bromine (Br) and Antimony (Sb) based flame retardants (Br or Sb do not exceed 0.1% by weight in homogeneous material)

⁽³⁾ MSL, Peak Temp. -- The Moisture Sensitivity Level rating according to the JEDEC industry standard classifications, and peak solder temperature.

Important Information and Disclaimer: The information provided on this page represents TI's knowledge and belief as of the date that it is provided. TI bases its knowledge and belief on information provided by third parties, and makes no representation or warranty as to the accuracy of such information. Efforts are underway to better integrate information from third parties. TI has taken and continues to take reasonable steps to provide representative and accurate information but may not have conducted destructive testing or chemical analysis on incoming materials and chemicals. TI and TI suppliers consider certain information to be proprietary, and thus CAS numbers and other limited information may not be available for release.

In no event shall TI's liability arising out of such information exceed the total purchase price of the TI part(s) at issue in this document sold by TI to Customer on an annual basis.

IMPORTANT NOTICE

Texas Instruments Incorporated and its subsidiaries (TI) reserve the right to make corrections, modifications, enhancements, improvements, and other changes to its products and services at any time and to discontinue any product or service without notice. Customers should obtain the latest relevant information before placing orders and should verify that such information is current and complete. All products are sold subject to TI's terms and conditions of sale supplied at the time of order acknowledgment.

TI warrants performance of its hardware products to the specifications applicable at the time of sale in accordance with TI's standard warranty. Testing and other quality control techniques are used to the extent TI deems necessary to support this warranty. Except where mandated by government requirements, testing of all parameters of each product is not necessarily performed.

TI assumes no liability for applications assistance or customer product design. Customers are responsible for their products and applications using TI components. To minimize the risks associated with customer products and applications, customers should provide adequate design and operating safeguards.

TI does not warrant or represent that any license, either express or implied, is granted under any TI patent right, copyright, mask work right, or other TI intellectual property right relating to any combination, machine, or process in which TI products or services are used. Information published by TI regarding third-party products or services does not constitute a license from TI to use such products or services or a warranty or endorsement thereof. Use of such information may require a license from a third party under the patents or other intellectual property of the third party, or a license from TI under the patents or other intellectual property of TI.

Reproduction of TI information in TI data books or data sheets is permissible only if reproduction is without alteration and is accompanied by all associated warranties, conditions, limitations, and notices. Reproduction of this information with alteration is an unfair and deceptive business practice. TI is not responsible or liable for such altered documentation. Information of third parties may be subject to additional restrictions.

Resale of TI products or services with statements different from or beyond the parameters stated by TI for that product or service voids all express and any implied warranties for the associated TI product or service and is an unfair and deceptive business practice. TI is not responsible or liable for any such statements.

TI products are not authorized for use in safety-critical applications (such as life support) where a failure of the TI product would reasonably be expected to cause severe personal injury or death, unless officers of the parties have executed an agreement specifically governing such use. Buyers represent that they have all necessary expertise in the safety and regulatory ramifications of their applications, and acknowledge and agree that they are solely responsible for all legal, regulatory and safety-related requirements concerning their products and any use of TI products in such safety-critical applications, notwithstanding any applications-related information or support that may be provided by TI. Further, Buyers must fully indemnify TI and its representatives against any damages arising out of the use of TI products in such safety-critical applications.

TI products are neither designed nor intended for use in military/aerospace applications or environments unless the TI products are specifically designated by TI as military-grade or "enhanced plastic." Only products designated by TI as military-grade meet military specifications. Buyers acknowledge and agree that any such use of TI products which TI has not designated as military-grade is solely at the Buyer's risk, and that they are solely responsible for compliance with all legal and regulatory requirements in connection with such use.

TI products are neither designed nor intended for use in automotive applications or environments unless the specific TI products are designated by TI as compliant with ISO/TS 16949 requirements. Buyers acknowledge and agree that, if they use any non-designated products in automotive applications, TI will not be responsible for any failure to meet such requirements.

Following are URLs where you can obtain information on other Texas Instruments products and application solutions:

Products

Amplifiers	amplifier.ti.com
Data Converters	dataconverter.ti.com
DLP® Products	www.dlp.com
DSP	dsp.ti.com
Clocks and Timers	www.ti.com/clocks
Interface	interface.ti.com
Logic	logic.ti.com
Power Mgmt	power.ti.com
Microcontrollers	microcontroller.ti.com
RFID	www.ti-rfid.com
RF/IF and ZigBee® Solutions	www.ti.com/lprf

Applications

Audio	www.ti.com/audio
Automotive	www.ti.com/automotive
Broadband	www.ti.com/broadband
Digital Control	www.ti.com/digitalcontrol
Medical	www.ti.com/medical
Military	www.ti.com/military
Optical Networking	www.ti.com/opticalnetwork
Security	www.ti.com/security
Telephony	www.ti.com/telephony
Video & Imaging	www.ti.com/video
Wireless	www.ti.com/wireless

Mailing Address: Texas Instruments, Post Office Box 655303, Dallas, Texas 75265
Copyright © 2009, Texas Instruments Incorporated