

- Single Chip With Easy Interface Between UART and Two Serial-Port Connectors of IBM™ PC/AT™ and Compatibles
- Meets or Exceeds the Requirements of TIA/EIA-232-F and ITU Recommendation V.28
- Supports Data Rates up to 120 kbit/s
- Package Options Include Plastic Thin Shrink Small-Outline (DGG) and Shrink Small-Outline (DL) Packages

**description**

The SN752232 consists of dual ports, each containing three drivers and five receivers, which reduce board space and allow easy interconnection of the UART and two serial-port connectors of an IBM™ PC/AT™ and compatibles. The bipolar circuits and processing of this “dual GD75232” provide, a rugged, low-cost solution for this function.

The SN752232 complies with the requirements of the TIA/EIA-232-F and ITU V.28 standards. These standards are for data interchange between a host computer and a peripheral at signaling rates up to 20 kbit/s. The device supports data rates up to 120 kbit/s with lower capacitive loads (shorter cables). Interoperability at the higher signaling rates cannot be expected unless the designer has design control of the cable and the interface circuits at both ends. For interoperability at signaling rates up to 120 kbit/s, use of TIA/EIA-423-B (ITU V.10) and TIA/EIA-422-B (ITU V.11) standards is recommended.

The SN752232 is characterized for operation over the temperature range of 0°C to 70°C.

DGG OR DL PACKAGE  
(TOP VIEW)

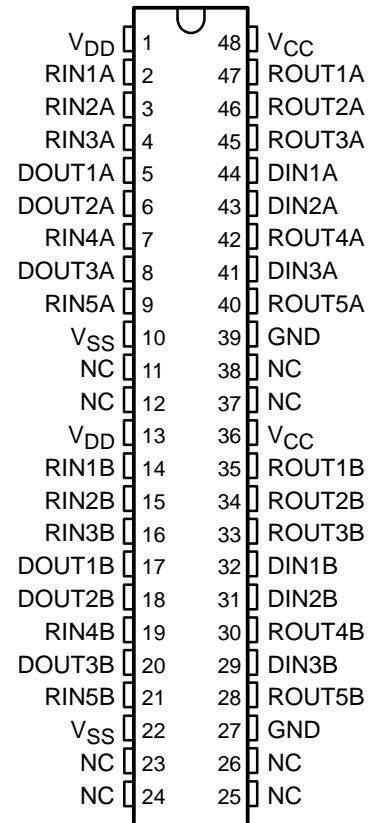

AVAILABLE OPTIONS

T <sub>A</sub>	PACKAGED DEVICES	
	PLASTIC SHRINK SMALL OUTLINE (DL)	PLASTIC THIN SHRINK SMALL OUTLINE (DGG)
0°C to 70°C	SN752232DL	SN752232DGG

The DL package also is available taped and reeled. Add the suffix R to the device type (e.g., SN752232DLR). The DGG package is only available taped and reeled.



Please be aware that an important notice concerning availability, standard warranty, and use in critical applications of Texas Instruments semiconductor products and disclaimers thereto appears at the end of this data sheet.

IBM and PC/AT are trademarks of International Business Machines Corporation.

PRODUCTION DATA information is current as of publication date. Products conform to specifications per the terms of Texas Instruments standard warranty. Production processing does not necessarily include testing of all parameters.



POST OFFICE BOX 655303 • DALLAS, TEXAS 75265

Copyright © 2001, Texas Instruments Incorporated

# SN752232 DUAL RS-232 PORT

SLLS507 – JUNE 2001

## logic diagram (positive logic)

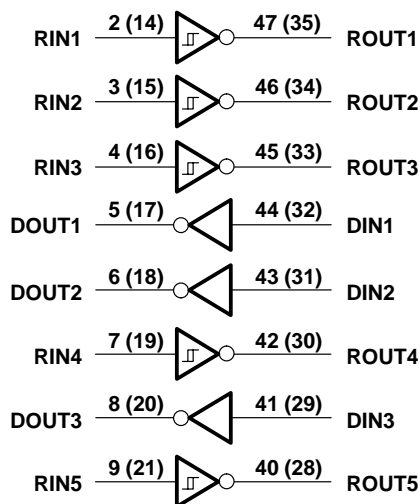

NOTE A: Numbers in parentheses are for B section.

## schematic (each driver)

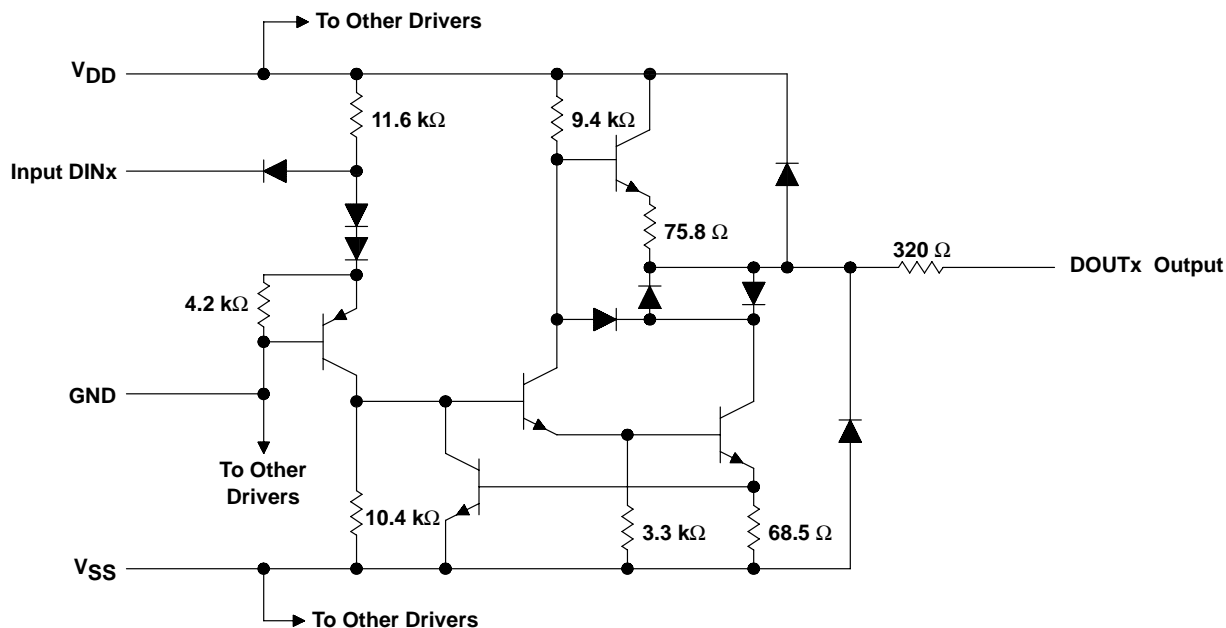

NOTE A: Resistor values shown are nominal.

schematic (each receiver)

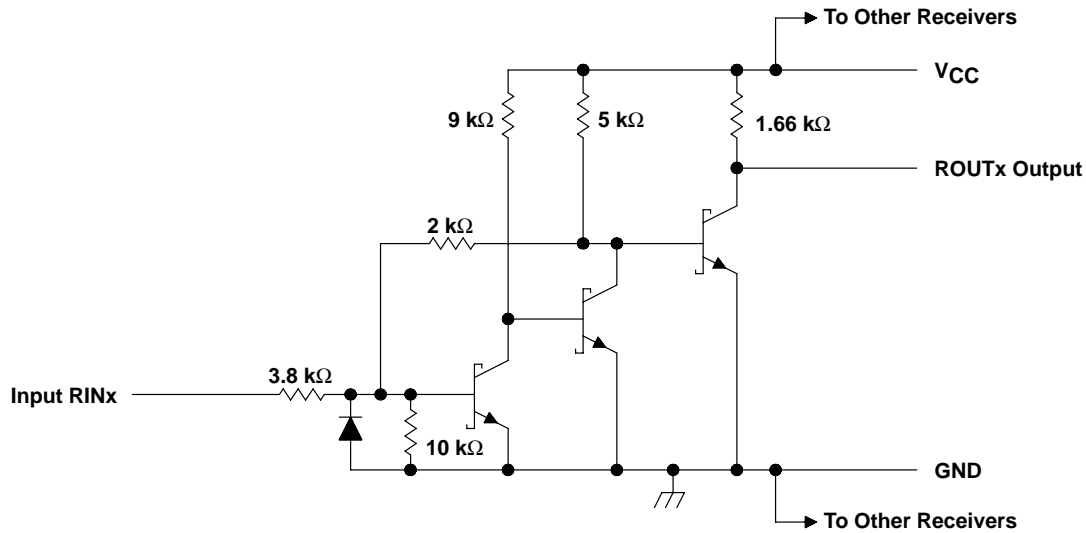

NOTE A: Resistor values shown are nominal.

absolute maximum ratings over operating free-air temperature range (unless otherwise noted)†

Supply voltage (see Note 1): $V_{CC}$ .....	10 V
$V_{DD}$ .....	15 V
$V_{SS}$ .....	-15 V
Input voltage range, $V_I$ : Driver .....	-15 V to 7 V
Receiver .....	-30 V to 30 V
Driver output voltage range, $V_O$ .....	-15 V to 15 V
Receiver low-level output current, $I_{OL}$ .....	20 mA
Package thermal impedance, $\theta_{JA}$ (see Note 2): DGG package .....	70°C/W
DL package .....	63°C/W
Lead temperature 1,6 mm (1/16 inch) from case for 10 seconds .....	260°C
Storage temperature range, $T_{stg}$ .....	-65°C to 150°C

† Stresses beyond those listed under “absolute maximum ratings” may cause permanent damage to the device. These are stress ratings only, and functional operation of the device at these or any other conditions beyond those indicated under “recommended operating conditions” is not implied. Exposure to absolute-maximum-rated conditions for extended periods may affect device reliability.

- NOTES: 1. All voltages are with respect to network GND.  
2. The package thermal impedance is calculated in accordance with JESD 51-7.

# SN752232 DUAL RS-232 PORT

SLLS507 – JUNE 2001

## recommended operating conditions

		MIN	NOM	MAX	UNIT
V <sub>DD</sub>	Supply voltage	7.5	9	15	V
V <sub>SS</sub>	Supply voltage	-7.5	-9	-15	V
V <sub>CC</sub>	Supply voltage	4.5	5	5.5	V
V <sub>IH</sub>	High-level input voltage (driver only)	1.9			V
V <sub>IL</sub>	Low-level input voltage (driver only)			0.8	V
I <sub>OH</sub>	High-level output current	Driver		-6	mA
		Receiver		-0.5	
I <sub>OL</sub>	Low-level output current	Driver		6	mA
		Receiver		16	
T <sub>A</sub>	Operating free-air temperature	0		70	°C

## supply currents over recommended operating free-air temperature range

PARAMETER	TEST CONDITIONS		MIN	MAX	UNIT
I <sub>DD</sub>	Supply current from V <sub>DD</sub>	All inputs at 1.9 V, No load	V <sub>DD</sub> = 9 V, V <sub>SS</sub> = -9 V	30	mA
			V <sub>DD</sub> = 12 V, V <sub>SS</sub> = -12 V	38	
			V <sub>DD</sub> = 15 V, V <sub>SS</sub> = -15 V	50	
	All inputs at 0.8 V, No load	V <sub>DD</sub> = 9 V, V <sub>SS</sub> = -9 V	9		
		V <sub>DD</sub> = 12 V, V <sub>SS</sub> = -12 V	11		
		V <sub>DD</sub> = 15 V, V <sub>SS</sub> = -15 V	18		
I <sub>SS</sub>	Supply current from V <sub>SS</sub>	All inputs at 1.9 V, No load	V <sub>DD</sub> = 9 V, V <sub>SS</sub> = -9 V	-30	mA
			V <sub>DD</sub> = 12 V, V <sub>SS</sub> = -12 V	-38	
			V <sub>DD</sub> = 15 V, V <sub>SS</sub> = -15 V	-50	
	All inputs at 0.8 V, No load	V <sub>DD</sub> = 9 V, V <sub>SS</sub> = -9 V	-6.4		
		V <sub>DD</sub> = 12 V, V <sub>SS</sub> = -12 V	-6.4		
		V <sub>DD</sub> = 15 V, V <sub>SS</sub> = -15 V	-6.4		
I <sub>CC</sub>	Supply current from V <sub>CC</sub>	V <sub>CC</sub> = 5 V, All inputs at 5 V, No load		60	mA

## DRIVER SECTION

### electrical characteristics over recommended operating free-air temperature range, V<sub>DD</sub> = 9 V, V<sub>SS</sub> = -9 V, V<sub>CC</sub> = 5 V (unless otherwise noted)

PARAMETER	TEST CONDITIONS		MIN	TYP	MAX	UNIT
V <sub>OH</sub>	High-level output voltage	V <sub>IL</sub> = 0.8 V, R <sub>L</sub> = 3 kΩ, See Figure 1	6	7.5		V
V <sub>OL</sub>	Low-level output voltage (see Note 3)	V <sub>IH</sub> = 1.9 V, R <sub>L</sub> = 3 kΩ, See Figure 1		-7.5	-6	V
I <sub>IH</sub>	High-level input current	V <sub>I</sub> = 5 V, See Figure 2			10	μA
I <sub>IL</sub>	Low-level input current	V <sub>I</sub> = 0, See Figure 2			-1.6	mA
I <sub>OS(H)</sub>	High-level short-circuit output current (see Note 4)	V <sub>IL</sub> = 0.8 V, V <sub>O</sub> = 0, See Figure 1	-4.5	-12	-19.5	mA
I <sub>OS(L)</sub>	Low-level short-circuit output current	V <sub>IH</sub> = 2 V, V <sub>O</sub> = 0, See Figure 1	4.5	12	19.5	mA
r <sub>O</sub>	Output resistance (see Note 5)	V <sub>CC</sub> = V <sub>DD</sub> = V <sub>SS</sub> = 0, V <sub>O</sub> = -2 V to 2 V	300			Ω

NOTES: 3. The algebraic convention, where the more positive (less negative) limit is designated as maximum, is used in this data sheet for logic levels only (e.g., if -10 V is maximum, the typical value is a more negative voltage).

4. Output short-circuit conditions must maintain the total power dissipation below absolute maximum ratings.

5. Test conditions are those specified by TIA/EIA-232-F and as listed above.



**switching characteristics,  $V_{CC} = 5\text{ V}$ ,  $V_{DD} = 12\text{ V}$ ,  $V_{SS} = -12\text{ V}$ ,  $T_A = 25^\circ\text{C}$  (see Figure 3)**

PARAMETER		TEST CONDITIONS		MIN	TYP	MAX	UNIT
$t_{PLH}$	Propagation delay time, low- to high-level output	$R_L = 3\text{ k}\Omega$ to $7\text{ k}\Omega$ ,	$C_L = 15\text{ pF}$		315	500	ns
$t_{PHL}$	Propagation delay time, high- to low-level output	$R_L = 3\text{ k}\Omega$ to $7\text{ k}\Omega$ ,	$C_L = 15\text{ pF}$		75	175	ns
$t_{TLH}$	Transition time, low- to high-level output	$R_L = 3\text{ k}\Omega$ to $7\text{ k}\Omega$	$C_L = 15\text{ pF}$		60	100	ns
			$C_L = 2500\text{ pF}$ , See Note 6		1.7	2.5	$\mu\text{s}$
$t_{THL}$	Transition time, high- to low-level output	$R_L = 3\text{ k}\Omega$ to $7\text{ k}\Omega$	$C_L = 15\text{ pF}$		40	75	ns
			$C_L = 2500\text{ pF}$ , See Note 6		1.5	2.5	$\mu\text{s}$

NOTE 6: Measured between  $\pm 3\text{-V}$  and  $\pm 3\text{-V}$  points of the output waveform (TIA/EIA-232-F conditions), all unused inputs are tied either high or low.

**RECEIVER SECTION**

**electrical characteristics over recommended operating conditions (unless otherwise noted)**

PARAMETER		TEST CONDITIONS		MIN	TYP†	MAX	UNIT
$V_{IT+}$	Positive-going input threshold voltage	$T_A = 25^\circ\text{C}$	See Figure 5	1.75	1.9	2.3	V
		$T_A = 0^\circ\text{C}$ to $70^\circ\text{C}$		1.55		2.3	
$V_{IT-}$	Negative-going input threshold voltage			0.75	0.97	1.25	V
$V_{hys}$	Input hysteresis voltage ( $V_{IT+} - V_{IT-}$ )			0.5			V
$V_{OH}$	High-level output voltage	$I_{OH} = -0.5\text{ mA}$	$V_{IH} = 0.75\text{ V}$	2.6	4	5	V
			Inputs open	2.6			
$V_{OL}$	Low-level input voltage	$I_{OL} = 10\text{ mA}$ ,	$V_I = 3\text{ V}$		0.2	0.45	V
$I_{IH}$	High-level input current	$V_I = 25\text{ V}$ ,	See Figure 5	3.6		8.8	mA
		$V_I = 3\text{ V}$ ,	See Figure 5	0.43			
$I_{IL}$	Low-level output current	$V_I = -25\text{ V}$ ,	See Figure 5	-3.6		-8.8	mA
		$V_I = -3\text{ V}$ ,	See Figure 5	-0.43			
$I_{OS}$	Short-circuit output current	See Figure 4		-3.4		-12	mA

† All typical values are at  $T_A = 25^\circ\text{C}$ ,  $V_{CC} = 5\text{ V}$ ,  $V_{DD} = 9\text{ V}$ , and  $V_{SS} = -9\text{ V}$ .

**switching characteristics,  $V_{CC} = 5\text{ V}$ ,  $V_{DD} = 12\text{ V}$ ,  $V_{SS} = -12\text{ V}$ ,  $T_A = 25^\circ\text{C}$  (see Figure 6)**

PARAMETER		TEST CONDITIONS		MIN	TYP	MAX	UNIT
$t_{PLH}$	Propagation delay time, low- to high-level output	$C_L = 50\text{ pF}$ ,	$R_L = 5\text{ k}\Omega$		107	250	ns
$t_{PHL}$	Propagation delay time, high- to low-level output				42	150	ns
$t_{TLH}$	Transition time, low- to high-level output				175	350	ns
$t_{THL}$	Transition time, high- to low-level output				16	60	ns
$t_{PLH}$	Propagation delay time, low- to high-level output	$C_L = 15\text{ pF}$ ,	$R_L = 1.5\text{ k}\Omega$		100	160	ns
$t_{PHL}$	Propagation delay time, high- to low-level output				60	100	ns
$t_{TLH}$	Transition time, low- to high-level output				90	175	ns
$t_{THL}$	Transition time, high- to low-level output				15	50	ns

PARAMETER MEASUREMENT INFORMATION

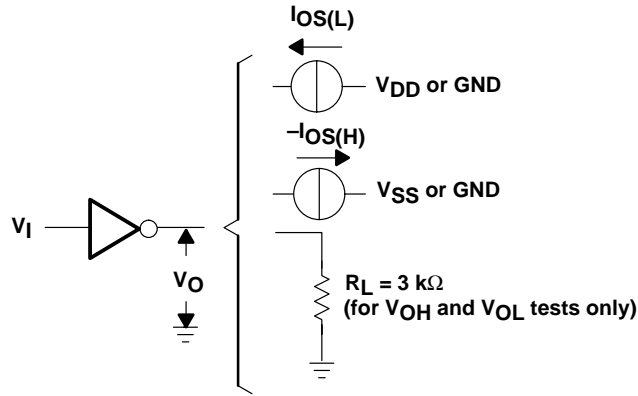

Figure 1. Driver Test Circuit for  $V_{OH}$ ,  $V_{OL}$ ,  $I_{OS(H)}$ , and  $I_{OS(L)}$

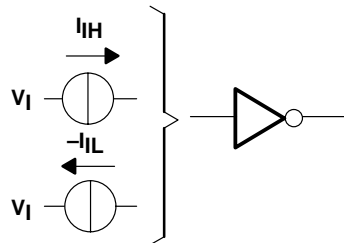
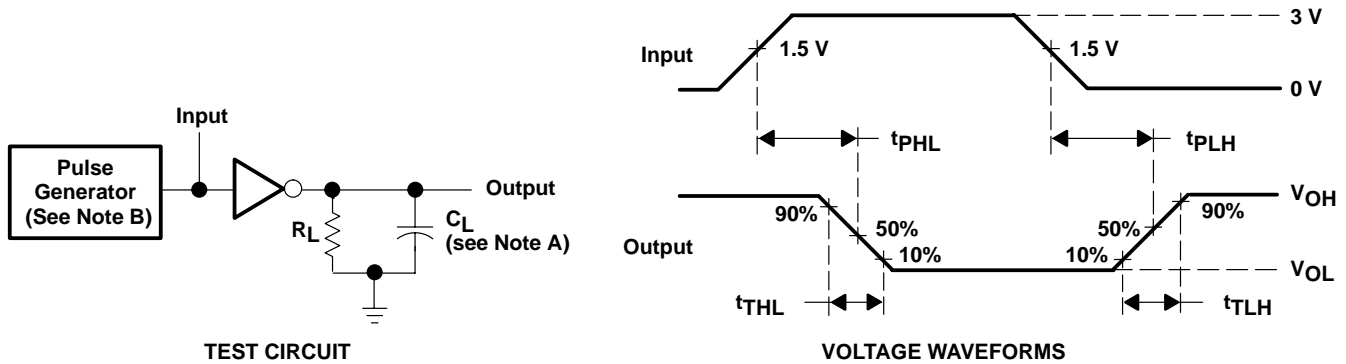

Figure 2. Driver Test Circuit for  $I_{IH}$  and  $I_{IL}$



NOTES: A.  $C_L$  includes probe and jig capacitance.  
 B. The pulse generator has the following characteristics:  $t_W = 25\ \mu\text{s}$ ,  $\text{PRR} = 20\ \text{kHz}$ ,  $Z_O = 50\ \Omega$ ,  $t_r = t_f < 50\ \text{ns}$ .

Figure 3. Driver Test Circuit and Voltage Waveforms

PARAMETER MEASUREMENT INFORMATION

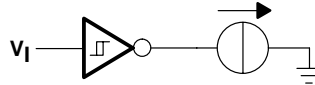

Figure 4. Receiver Test Circuit for  $I_{0S}$

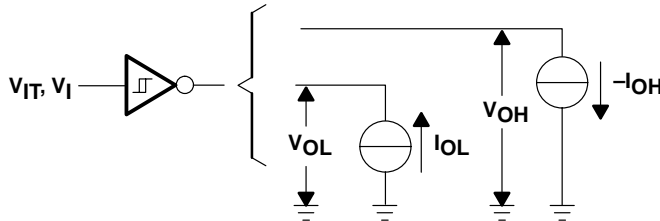
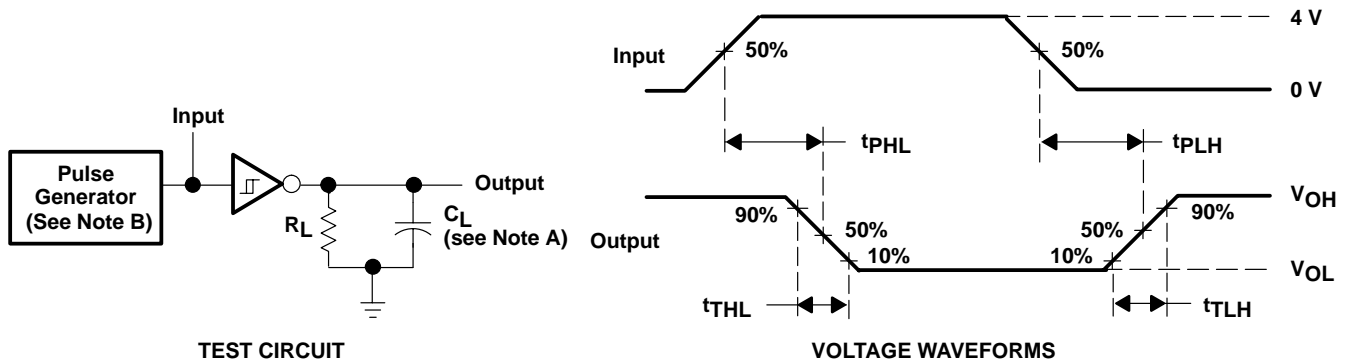

Figure 5. Receiver Test Circuit for  $V_{IT}$ ,  $V_{OH}$ , and  $V_{OL}$



NOTES: A.  $C_L$  includes probe and jig capacitance.  
B. The pulse generator has the following characteristics:  $t_w = 25 \mu s$ ,  $PRR = 20 \text{ kHz}$ ,  $Z_O = 50 \Omega$ ,  $t_r = t_f < 50 \text{ ns}$ .

Figure 6. Receiver Propagation and Transition Times

TYPICAL CHARACTERISTICS  
DRIVER SECTION

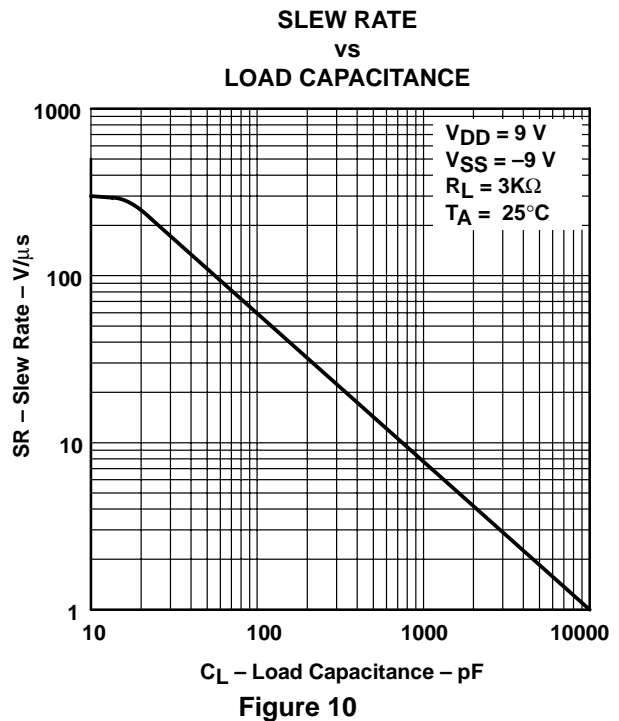
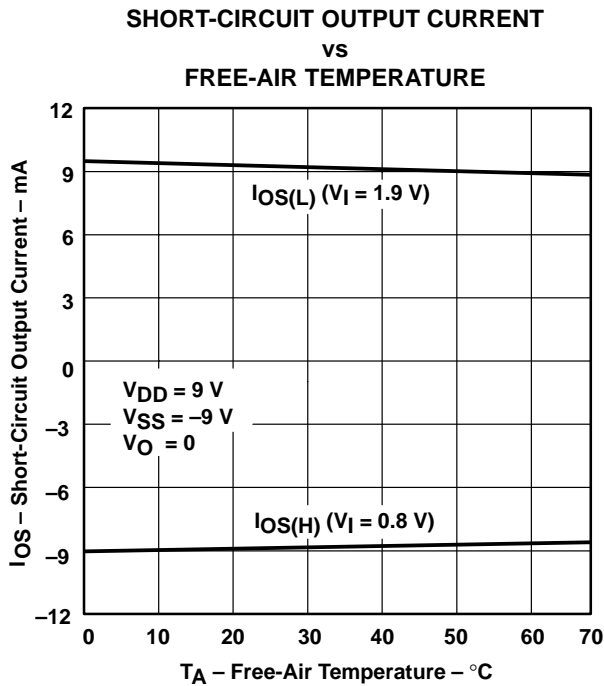
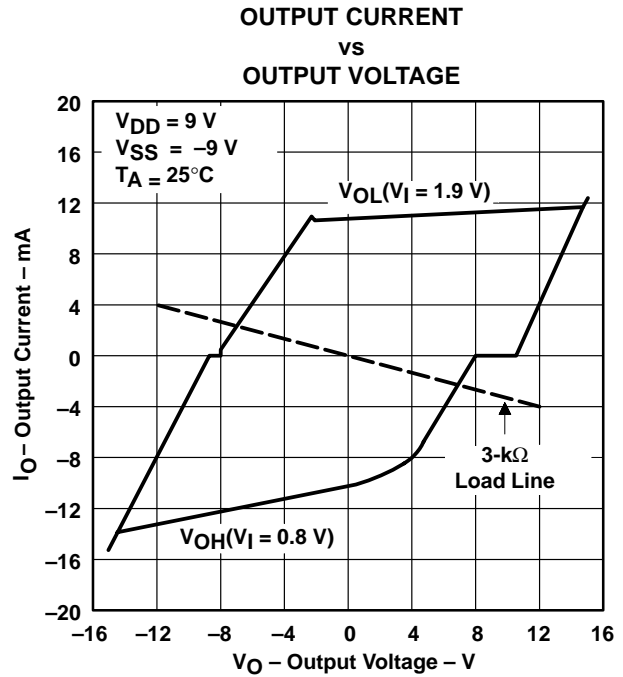
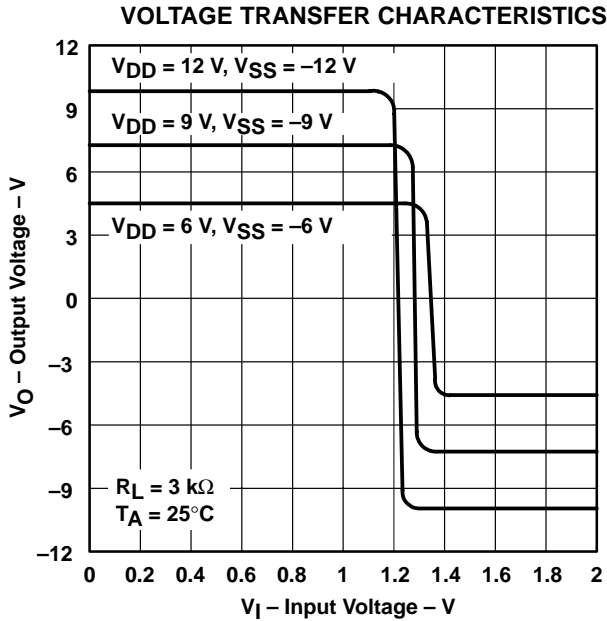

TYPICAL CHARACTERISTICS

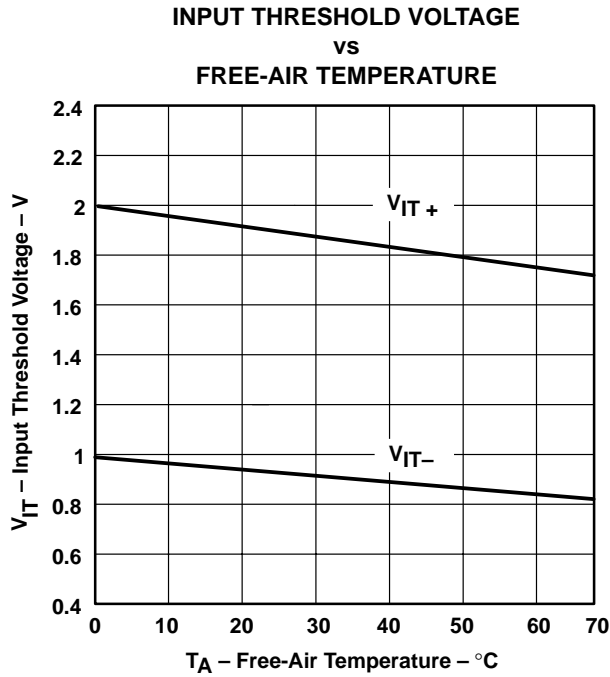

Figure 11

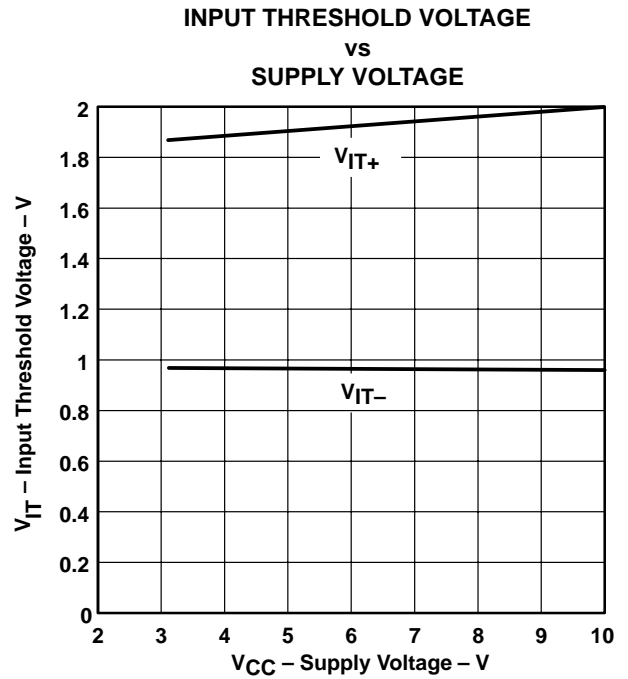
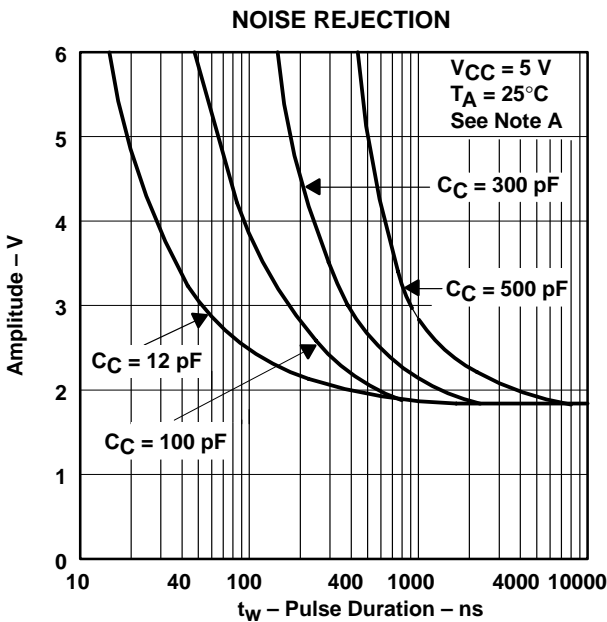

Figure 12



NOTE A: This figure shows the maximum amplitude of a positive-going pulse that, starting from 0 V, does not cause a change of the output level.

Figure 13

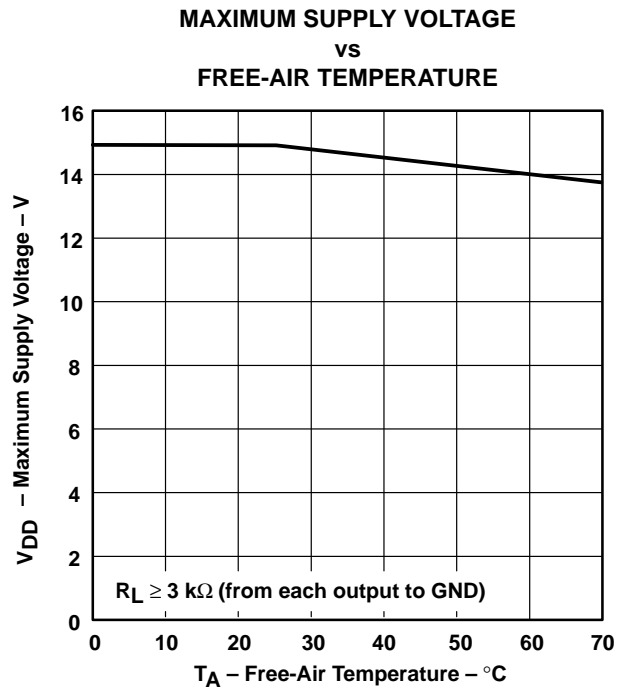

Figure 14

# SN752232 DUAL RS-232 PORT

SLLS507 – JUNE 2001

## APPLICATION INFORMATION

Diodes placed in series with the  $V_{DD}$  and  $V_{SS}$  leads protect the SN752232 in the fault condition in which the device outputs are shorted to  $\pm 15$  V, and the power supplies are at low and provide low-impedance paths to ground (see Figure 15).

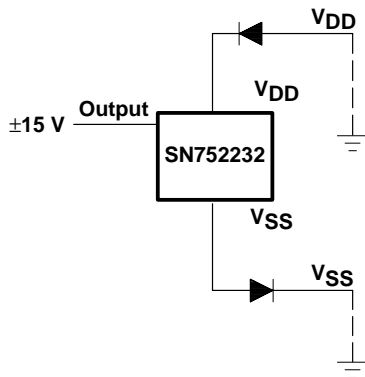
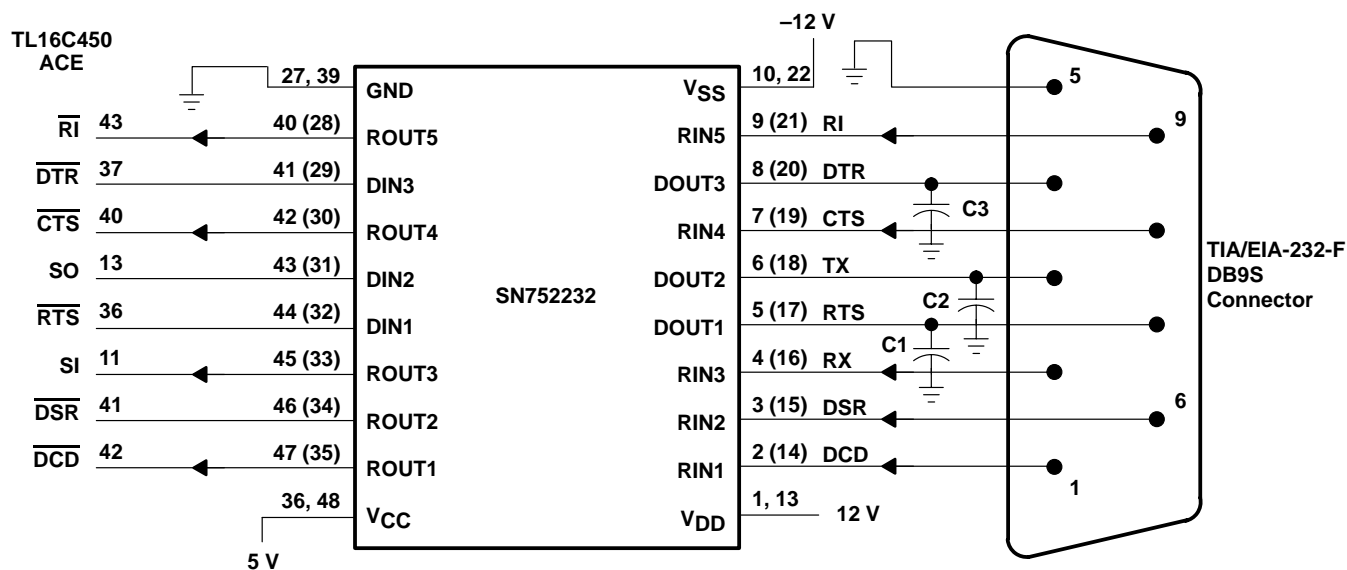

Figure 15. Power-Supply Protection to Meet Power-Off Fault Conditions of TIA/EIA-232-F



NOTE A: Numbers in parentheses are for B section.

Figure 16. Typical Connection Per Port

**PACKAGING INFORMATION**

Orderable Device	Status <sup>(1)</sup>	Package Type	Package Drawing	Pins	Package Qty	Eco Plan <sup>(2)</sup>	Lead/Ball Finish	MSL Peak Temp <sup>(3)</sup>
SN752232DGGR	ACTIVE	TSSOP	DGG	48	2000	Green (RoHS & no Sb/Br)	CU NIPDAU	Level-1-260C-UNLIM
SN752232DGGRE4	ACTIVE	TSSOP	DGG	48	2000	Green (RoHS & no Sb/Br)	CU NIPDAU	Level-1-260C-UNLIM
SN752232DGGRG4	ACTIVE	TSSOP	DGG	48	2000	Green (RoHS & no Sb/Br)	CU NIPDAU	Level-1-260C-UNLIM
SN752232DLR	ACTIVE	SSOP	DL	48	1000	Green (RoHS & no Sb/Br)	CU NIPDAU	Level-1-260C-UNLIM
SN752232DLRG4	ACTIVE	SSOP	DL	48	1000	Green (RoHS & no Sb/Br)	CU NIPDAU	Level-1-260C-UNLIM

<sup>(1)</sup> The marketing status values are defined as follows:

**ACTIVE:** Product device recommended for new designs.

**LIFEBUY:** TI has announced that the device will be discontinued, and a lifetime-buy period is in effect.

**NRND:** Not recommended for new designs. Device is in production to support existing customers, but TI does not recommend using this part in a new design.

**PREVIEW:** Device has been announced but is not in production. Samples may or may not be available.

**OBSOLETE:** TI has discontinued the production of the device.

<sup>(2)</sup> Eco Plan - The planned eco-friendly classification: Pb-Free (RoHS), Pb-Free (RoHS Exempt), or Green (RoHS & no Sb/Br) - please check <http://www.ti.com/productcontent> for the latest availability information and additional product content details.

**TBD:** The Pb-Free/Green conversion plan has not been defined.

**Pb-Free (RoHS):** TI's terms "Lead-Free" or "Pb-Free" mean semiconductor products that are compatible with the current RoHS requirements for all 6 substances, including the requirement that lead not exceed 0.1% by weight in homogeneous materials. Where designed to be soldered at high temperatures, TI Pb-Free products are suitable for use in specified lead-free processes.

**Pb-Free (RoHS Exempt):** This component has a RoHS exemption for either 1) lead-based flip-chip solder bumps used between the die and package, or 2) lead-based die adhesive used between the die and leadframe. The component is otherwise considered Pb-Free (RoHS compatible) as defined above.

**Green (RoHS & no Sb/Br):** TI defines "Green" to mean Pb-Free (RoHS compatible), and free of Bromine (Br) and Antimony (Sb) based flame retardants (Br or Sb do not exceed 0.1% by weight in homogeneous material)

<sup>(3)</sup> MSL, Peak Temp. -- The Moisture Sensitivity Level rating according to the JEDEC industry standard classifications, and peak solder temperature.

**Important Information and Disclaimer:**The information provided on this page represents TI's knowledge and belief as of the date that it is provided. TI bases its knowledge and belief on information provided by third parties, and makes no representation or warranty as to the accuracy of such information. Efforts are underway to better integrate information from third parties. TI has taken and continues to take reasonable steps to provide representative and accurate information but may not have conducted destructive testing or chemical analysis on incoming materials and chemicals. TI and TI suppliers consider certain information to be proprietary, and thus CAS numbers and other limited information may not be available for release.

In no event shall TI's liability arising out of such information exceed the total purchase price of the TI part(s) at issue in this document sold by TI to Customer on an annual basis.

**TAPE AND REEL INFORMATION**

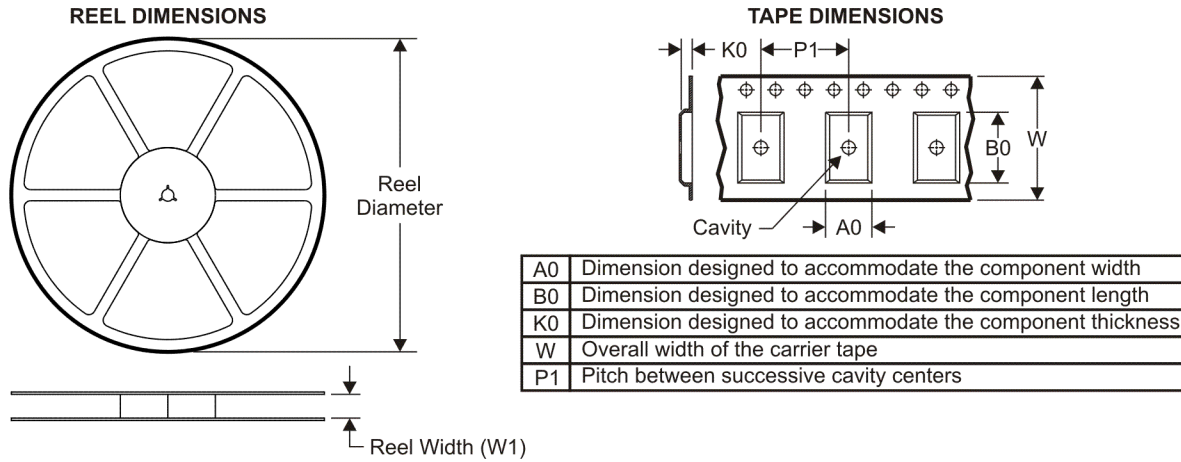

**QUADRANT ASSIGNMENTS FOR PIN 1 ORIENTATION IN TAPE**



\*All dimensions are nominal

Device	Package Type	Package Drawing	Pins	SPQ	Reel Diameter (mm)	Reel Width W1 (mm)	A0 (mm)	B0 (mm)	K0 (mm)	P1 (mm)	W (mm)	Pin1 Quadrant
SN752232DGGR	TSSOP	DGG	48	2000	330.0	24.4	8.6	15.8	1.8	12.0	24.0	Q1
SN752232DLR	SSOP	DL	48	1000	330.0	32.4	11.35	16.2	3.1	16.0	32.0	Q1

**TAPE AND REEL BOX DIMENSIONS**



\*All dimensions are nominal

Device	Package Type	Package Drawing	Pins	SPQ	Length (mm)	Width (mm)	Height (mm)
SN752232DGGR	TSSOP	DGG	48	2000	346.0	346.0	41.0
SN752232DLR	SSOP	DL	48	1000	346.0	346.0	49.0

DGG (R-PDSO-G\*\*)

PLASTIC SMALL-OUTLINE PACKAGE

48 PINS SHOWN



- NOTES: A. All linear dimensions are in millimeters.  
 B. This drawing is subject to change without notice.  
 C. Body dimensions do not include mold protrusion not to exceed 0,15.  
 D. Falls within JEDEC MO-153

DL (R-PDSO-G\*\*)

PLASTIC SMALL-OUTLINE PACKAGE

48 PINS SHOWN



- NOTES: A. All linear dimensions are in inches (millimeters).  
 B. This drawing is subject to change without notice.  
 C. Body dimensions do not include mold flash or protrusion not to exceed 0.006 (0,15).  
 D. Falls within JEDEC MO-118

## IMPORTANT NOTICE

Texas Instruments Incorporated and its subsidiaries (TI) reserve the right to make corrections, modifications, enhancements, improvements, and other changes to its products and services at any time and to discontinue any product or service without notice. Customers should obtain the latest relevant information before placing orders and should verify that such information is current and complete. All products are sold subject to TI's terms and conditions of sale supplied at the time of order acknowledgment.

TI warrants performance of its hardware products to the specifications applicable at the time of sale in accordance with TI's standard warranty. Testing and other quality control techniques are used to the extent TI deems necessary to support this warranty. Except where mandated by government requirements, testing of all parameters of each product is not necessarily performed.

TI assumes no liability for applications assistance or customer product design. Customers are responsible for their products and applications using TI components. To minimize the risks associated with customer products and applications, customers should provide adequate design and operating safeguards.

TI does not warrant or represent that any license, either express or implied, is granted under any TI patent right, copyright, mask work right, or other TI intellectual property right relating to any combination, machine, or process in which TI products or services are used. Information published by TI regarding third-party products or services does not constitute a license from TI to use such products or services or a warranty or endorsement thereof. Use of such information may require a license from a third party under the patents or other intellectual property of the third party, or a license from TI under the patents or other intellectual property of TI.

Reproduction of TI information in TI data books or data sheets is permissible only if reproduction is without alteration and is accompanied by all associated warranties, conditions, limitations, and notices. Reproduction of this information with alteration is an unfair and deceptive business practice. TI is not responsible or liable for such altered documentation. Information of third parties may be subject to additional restrictions.

Resale of TI products or services with statements different from or beyond the parameters stated by TI for that product or service voids all express and any implied warranties for the associated TI product or service and is an unfair and deceptive business practice. TI is not responsible or liable for any such statements.

TI products are not authorized for use in safety-critical applications (such as life support) where a failure of the TI product would reasonably be expected to cause severe personal injury or death, unless officers of the parties have executed an agreement specifically governing such use. Buyers represent that they have all necessary expertise in the safety and regulatory ramifications of their applications, and acknowledge and agree that they are solely responsible for all legal, regulatory and safety-related requirements concerning their products and any use of TI products in such safety-critical applications, notwithstanding any applications-related information or support that may be provided by TI. Further, Buyers must fully indemnify TI and its representatives against any damages arising out of the use of TI products in such safety-critical applications.

TI products are neither designed nor intended for use in military/aerospace applications or environments unless the TI products are specifically designated by TI as military-grade or "enhanced plastic." Only products designated by TI as military-grade meet military specifications. Buyers acknowledge and agree that any such use of TI products which TI has not designated as military-grade is solely at the Buyer's risk, and that they are solely responsible for compliance with all legal and regulatory requirements in connection with such use.

TI products are neither designed nor intended for use in automotive applications or environments unless the specific TI products are designated by TI as compliant with ISO/TS 16949 requirements. Buyers acknowledge and agree that, if they use any non-designated products in automotive applications, TI will not be responsible for any failure to meet such requirements.

Following are URLs where you can obtain information on other Texas Instruments products and application solutions:

### Products

Amplifiers	<a href="http://amplifier.ti.com">amplifier.ti.com</a>
Data Converters	<a href="http://dataconverter.ti.com">dataconverter.ti.com</a>
DLP® Products	<a href="http://www.dlp.com">www.dlp.com</a>
DSP	<a href="http://dsp.ti.com">dsp.ti.com</a>
Clocks and Timers	<a href="http://www.ti.com/clocks">www.ti.com/clocks</a>
Interface	<a href="http://interface.ti.com">interface.ti.com</a>
Logic	<a href="http://logic.ti.com">logic.ti.com</a>
Power Mgmt	<a href="http://power.ti.com">power.ti.com</a>
Microcontrollers	<a href="http://microcontroller.ti.com">microcontroller.ti.com</a>
RFID	<a href="http://www.ti-rfid.com">www.ti-rfid.com</a>
RF/IF and ZigBee® Solutions	<a href="http://www.ti.com/lprf">www.ti.com/lprf</a>

### Applications

Audio	<a href="http://www.ti.com/audio">www.ti.com/audio</a>
Automotive	<a href="http://www.ti.com/automotive">www.ti.com/automotive</a>
Broadband	<a href="http://www.ti.com/broadband">www.ti.com/broadband</a>
Digital Control	<a href="http://www.ti.com/digitalcontrol">www.ti.com/digitalcontrol</a>
Medical	<a href="http://www.ti.com/medical">www.ti.com/medical</a>
Military	<a href="http://www.ti.com/military">www.ti.com/military</a>
Optical Networking	<a href="http://www.ti.com/opticalnetwork">www.ti.com/opticalnetwork</a>
Security	<a href="http://www.ti.com/security">www.ti.com/security</a>
Telephony	<a href="http://www.ti.com/telephony">www.ti.com/telephony</a>
Video & Imaging	<a href="http://www.ti.com/video">www.ti.com/video</a>
Wireless	<a href="http://www.ti.com/wireless">www.ti.com/wireless</a>

Mailing Address: Texas Instruments, Post Office Box 655303, Dallas, Texas 75265  
Copyright © 2009, Texas Instruments Incorporated