

Package Number 208 - 24-Lead Side Braze DIP, .600 Wide, ISO Package

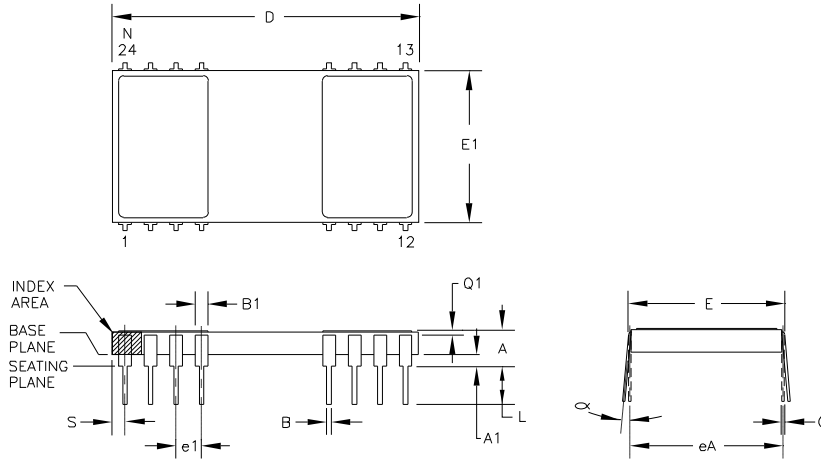

DIM	INCHES		MILLIMETERS		N	E
	MIN.	MAX.	MIN.	MAX.		
A	.085	.190	2.16	4.83		
A1	.020	.070	0.51	1.78		
B	.015	.023	0.38	0.58	5	
B1	.038	.060	0.97	1.52	5	
C	.008	.012	0.20	0.30		
D	1.180	1.220	29.97	30.99		
E	.595	.625	15.11	15.88		
E1	.580	.610	14.73	15.49	6	
e1	.100	TYP.	2.54	TYP.	2	
eA	.600	TYP.	15.24	TYP.	2	
L	.125	.175	3.18	4.45		
N	16		16		4	
Q1	.010	--	0.25	--		
S	.030	.065	0.76	1.65		

NOTES:

1. DIMENSIONING AND TOLERANCING PER ANSI Y14.5-1973.
2. LEADS WITHIN .005 IN. (0.13mm) RADIUS OF TRUE POSITION (TP) AT GAUGE PLANE WITH MAXIMUM MATERIAL CONDITION AND UNIT INSTALLED.
3.  $\infty$  APPLIES TO SPREAD LEADS PRIOR TO INSTALLATION.
4. N IS THE NUMBER OF TERMINAL POSITIONS.

5. OUTLINES ON WHICH THE SEATING PLANE IS COINCIDENT WITH THE PLANE (A1 = 0), TERMINALS LEAD STANDOFFS ARE NOT REQUIRED, AND B1 MAY EQUAL B ALONG ANY PART OF THE LEAD ABOVE THE SEATING/BASE PLANE.
6. E1 DOES NOT INCLUDE PARTICLES OF PACKING MATERIALS.
7. CONTROLLING DIMENSION: INCH.
8. A VISUAL INDEX FEATURE MUST BE LOCATED WITHIN THE CROSS-HATCHED AREA.

PACKAGE NUMBER: ZZ208      REV.: C  
 JEDEC NUMBER: MO-038-AA  
 WITH THE EXCEPTION OF "N"



PACKAGE DRAWING

## **IMPORTANT NOTICE**

Texas Instruments and its subsidiaries (TI) reserve the right to make changes to their products or to discontinue any product or service without notice, and advise customers to obtain the latest version of relevant information to verify, before placing orders, that information being relied on is current and complete. All products are sold subject to the terms and conditions of sale supplied at the time of order acknowledgment, including those pertaining to warranty, patent infringement, and limitation of liability.

TI warrants performance of its semiconductor products to the specifications applicable at the time of sale in accordance with TI's standard warranty. Testing and other quality control techniques are utilized to the extent TI deems necessary to support this warranty. Specific testing of all parameters of each device is not necessarily performed, except those mandated by government requirements.

Customers are responsible for their applications using TI components.

In order to minimize risks associated with the customer's applications, adequate design and operating safeguards must be provided by the customer to minimize inherent or procedural hazards.

TI assumes no liability for applications assistance or customer product design. TI does not warrant or represent that any license, either express or implied, is granted under any patent right, copyright, mask work right, or other intellectual property right of TI covering or relating to any combination, machine, or process in which such semiconductor products or services might be or are used. TI's publication of information regarding any third party's products or services does not constitute TI's approval, warranty or endorsement thereof.