

-Texas Instruments

Power Interface Products

ATCA AMC Hot Swap Reference Design Using TPS2490 and TPS2331

This reference design uses the TPS2490 and TPS2331 Hotswap controllers to manage the power feeds to an ATCA (Advanced Telecommunications Computing Architecture) AMC (Advanced Mezzanine Card). The TPS2490 manages the 12 V payload power (PWR) and the TPS2331 manages the 3.3 V management power (MP). Maximum power dissipation for an AMC is 60 W, most of which will be supplied by the 12 V payload power source. The PICMG.AMC specification requires both supplies to be inrush controlled and current limited.

PAYLOAD POWER

The TPS2490 limits 12 V payload power to 5.6 A which allows 60 W of power to the AMC even at the minimum input voltage of 10.8 V. Power dissipated by Q2 is limited to 12W by the TPS2490 and fault time is set to 3.5 ms. If AMC bulk capacitance charge time necessitates a longer fault time C5 may be increased according to instructions in the datasheet. In the event of an overcurrent fault the TPS2490 will latch off and remain off until EN is cycled. PICMG.AMC requires the reset signal to come from the IPMI (Intelligent Platform Management Interface) controller as shown.

MANAGEMENT POWER

3.3 Volt MP is derived from the Carrier Management Power as specified by PICMG.AMC. The TPS2331 undervoltage (UV) level has been set to 2.9 V and the output will not turn on until this level has been exceeded. If the output drops below this level PG (POWERGOOD) will de-assert. The overcurrent level is set to shutoff the output if current drawn by the AMC exceeds 125 mA. C3 sets the fault time to 2.2 ms to allow charging of any MP capacitors on the AMC without triggering nuisance faults.

INTERFACE LOGIC

The 4 gates in U3 and U4 provide the necessary logic to comply with PICMG.AMC. Along with insertion detection pins PS0 and PS1 they ensure;

1. Enable for PWR and MP are gated by full insertion of the AMC
2. Separate enables for MP and PWR
3. Power Good signals from MP and PWR provided to the IPMI
4. PRESENCE signal provided to IPMI

ADDITIONAL INFORMATION

Datasheets, application notes, and evaluation modules for the TPS2490 and TPS2331 may be found at www.power.ti.com. There are also ATCA specific reference designs for the TPS2393 and TPS2350 -48V Hotswap Power managers.

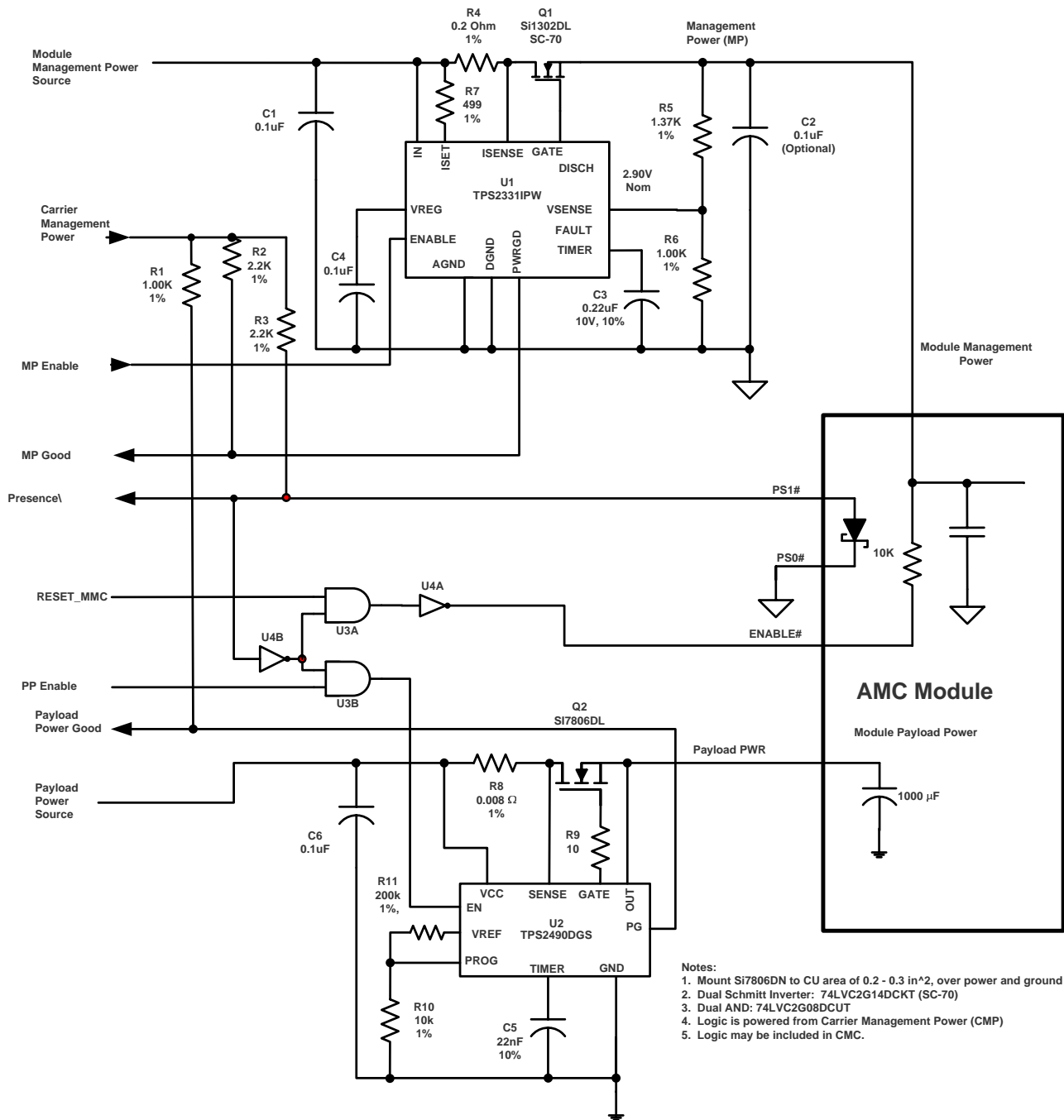

FIGURE 1 ATCA AMC Hotswap Using the TPS2490 and TPS2331

QTY	RefDes	DESCRIPTION	SIZE	MFR	Part Number
1	U1	IC, Dual Positive Low Voltage Hotswap Controller	PW20	TI	TPS2331IPW
1	U2	IC, Power Limiting HV Hot-Swap Controller	MSOP10	TI	TPS2491DGS
1	U3	IC, Logic, Dual AND Gate	SC-70	TI	SN74LVC2G08DCUT
1	U4	IC, Logic, Dual Inverter	SC-70	TI	SN74LVC2G04DCUT
1	Q1	MOSFET, N-ch, 30-V, 0.64-A, 700-mOhms	SC-70	Vishay	SI1302DL
1	Q2	MOSFET, N-ch, 30-V, 14-A, 15-mOhms	PowerPak™	Vishay	SI7806DN
4	C1, C2, C4, C6	Capacitor, Ceramic, 0.1-uF, 16V, X7R, 10%	805	Vishay	STD
1	C3	Capacitor, Ceramic, 0.22-uF, 16V, X7R, 10%	805	Vishay	STD
1	C5	Capacitor, Ceramic, 22 nF, 16V, X7R, 10%	805	Vishay	STD
2	R1, R6	Resistor, Chip, 1000-Ohms, 1/10-W, 1%	805	Vishay	STD
2	R2, R3	Resistor, Chip, 2200 Ohms, 1/10 -W	805	Vishay	STD
1	R4	Resistor, Chip, 0.2 Ohms, 1/4W, 1%	1206	Vishay	WSL-0805 0.200 1%
1	R5	Resistor, Chip, 1.37K - Ohms, 1/10W, 1%	603	Vishay	STD
1	R7	Resistor, Chip, 499 -Ohms, 1/10W, 1%	603	Vishay	STD
1	R8	Resistor, Chip, 8 milliOhm 0.25 Watt 1%	1206	Vishay	WSL-1206 0.008 1%
1	R9	Resistor, Chip, 10-Ohms, 1/10W, 5%	603	Vishay	STD
1	R10	Resistor, Chip, 10K-Ohms, 1/10W, 1%	603	Vishay	STD
1	R11	Resistor, Chip, 200K-Ohms, 1/10W, 1%	603	Vishay	STD

TABLE 2 Bill of Materials for ATCA AMC Hotswap Reference Design

IMPORTANT NOTICE

Texas Instruments Incorporated and its subsidiaries (TI) reserve the right to make corrections, modifications, enhancements, improvements, and other changes to its products and services at any time and to discontinue any product or service without notice. Customers should obtain the latest relevant information before placing orders and should verify that such information is current and complete. All products are sold subject to TI's terms and conditions of sale supplied at the time of order acknowledgment.

TI warrants performance of its hardware products to the specifications applicable at the time of sale in accordance with TI's standard warranty. Testing and other quality control techniques are used to the extent TI deems necessary to support this warranty. Except where mandated by government requirements, testing of all parameters of each product is not necessarily performed.

TI assumes no liability for applications assistance or customer product design. Customers are responsible for their products and applications using TI components. To minimize the risks associated with customer products and applications, customers should provide adequate design and operating safeguards.

TI does not warrant or represent that any license, either express or implied, is granted under any TI patent right, copyright, mask work right, or other TI intellectual property right relating to any combination, machine, or process in which TI products or services are used. Information published by TI regarding third-party products or services does not constitute a license from TI to use such products or services or a warranty or endorsement thereof. Use of such information may require a license from a third party under the patents or other intellectual property of the third party, or a license from TI under the patents or other intellectual property of TI.

Reproduction of information in TI data books or data sheets is permissible only if reproduction is without alteration and is accompanied by all associated warranties, conditions, limitations, and notices. Reproduction of this information with alteration is an unfair and deceptive business practice. TI is not responsible or liable for such altered documentation.

Resale of TI products or services with statements different from or beyond the parameters stated by TI for that product or service voids all express and any implied warranties for the associated TI product or service and is an unfair and deceptive business practice. TI is not responsible or liable for any such statements.

Following are URLs where you can obtain information on other Texas Instruments products and application solutions:

Products		Applications	
Amplifiers	amplifier.ti.com	Audio	www.ti.com/audio
Data Converters	dataconverter.ti.com	Automotive	www.ti.com/automotive
DSP	dsp.ti.com	Broadband	www.ti.com/broadband
Interface	interface.ti.com	Digital Control	www.ti.com/digitalcontrol
Logic	logic.ti.com	Military	www.ti.com/military
Power Mgmt	power.ti.com	Optical Networking	www.ti.com/opticalnetwork
Microcontrollers	microcontroller.ti.com	Security	www.ti.com/security
		Telephony	www.ti.com/telephony
		Video & Imaging	www.ti.com/video
		Wireless	www.ti.com/wireless

Mailing Address: Texas Instruments
Post Office Box 655303 Dallas, Texas 75265