

DEM-PCM2901/2903 EVM

User's Guide

IMPORTANT NOTICE

Texas Instruments Incorporated and its subsidiaries (TI) reserve the right to make corrections, modifications, enhancements, improvements, and other changes to its products and services at any time and to discontinue any product or service without notice. Customers should obtain the latest relevant information before placing orders and should verify that such information is current and complete. All products are sold subject to TI's terms and conditions of sale supplied at the time of order acknowledgment.

TI warrants performance of its hardware products to the specifications applicable at the time of sale in accordance with TI's standard warranty. Testing and other quality control techniques are used to the extent TI deems necessary to support this warranty. Except where mandated by government requirements, testing of all parameters of each product is not necessarily performed.

TI assumes no liability for applications assistance or customer product design. Customers are responsible for their products and applications using TI components. To minimize the risks associated with customer products and applications, customers should provide adequate design and operating safeguards.

TI does not warrant or represent that any license, either express or implied, is granted under any TI patent right, copyright, mask work right, or other TI intellectual property right relating to any combination, machine, or process in which TI products or services are used. Information published by TI regarding third-party products or services does not constitute a license from TI to use such products or services or a warranty or endorsement thereof. Use of such information may require a license from a third party under the patents or other intellectual property of the third party, or a license from TI under the patents or other intellectual property of TI.

Reproduction of information in TI data books or data sheets is permissible only if reproduction is without alteration and is accompanied by all associated warranties, conditions, limitations, and notices. Reproduction of this information with alteration is an unfair and deceptive business practice. TI is not responsible or liable for such altered documentation.

Resale of TI products or services with statements different from or beyond the parameters stated by TI for that product or service voids all express and any implied warranties for the associated TI product or service and is an unfair and deceptive business practice. TI is not responsible or liable for any such statements.

Mailing Address:

Texas Instruments
Post Office Box 655303
Dallas, Texas 75265

EVM IMPORTANT NOTICE

Texas Instruments (TI) provides the enclosed product(s) under the following conditions:

This evaluation kit being sold by TI is intended for use for **ENGINEERING DEVELOPMENT OR EVALUATION PURPOSES ONLY** and is not considered by TI to be fit for commercial use. As such, the goods being provided may not be complete in terms of required design-, marketing-, and/or manufacturing-related protective considerations, including product safety measures typically found in the end product incorporating the goods. As a prototype, this product does not fall within the scope of the European Union directive on electromagnetic compatibility and therefore may not meet the technical requirements of the directive.

Should this evaluation kit not meet the specifications indicated in the EVM User's Guide, the kit may be returned within 30 days from the date of delivery for a full refund. **THE FOREGOING WARRANTY IS THE EXCLUSIVE WARRANTY MADE BY SELLER TO BUYER AND IS IN LIEU OF ALL OTHER WARRANTIES, EXPRESSED, IMPLIED, OR STATUTORY, INCLUDING ANY WARRANTY OF MERCHANTABILITY OR FITNESS FOR ANY PARTICULAR PURPOSE.**

The user assumes all responsibility and liability for proper and safe handling of the goods. Further, the user indemnifies TI from all claims arising from the handling or use of the goods. Please be aware that the products received may not be regulatory compliant or agency certified (FCC, UL, CE, etc.). Due to the open construction of the product, it is the user's responsibility to take any and all appropriate precautions with regard to electrostatic discharge.

EXCEPT TO THE EXTENT OF THE INDEMNITY SET FORTH ABOVE, NEITHER PARTY SHALL BE LIABLE TO THE OTHER FOR ANY INDIRECT, SPECIAL, INCIDENTAL, OR CONSEQUENTIAL DAMAGES.

TI currently deals with a variety of customers for products, and therefore our arrangement with the user **is not exclusive**.

TI assumes **no liability for applications assistance, customer product design, software performance, or infringement of patents or services described herein**.

Please read the EVM User's Guide and, specifically, the EVM Warnings and Restrictions notice in the EVM User's Guide prior to handling the product. This notice contains important safety information about temperatures and voltages. For further safety concerns, please contact the TI application engineer.

Persons handling the product must have electronics training and observe good laboratory practice standards.

No license is granted under any patent right or other intellectual property right of TI covering or relating to any machine, process, or combination in which such TI products or services might be or are used.

Mailing Address:

Texas Instruments
Post Office Box 655303
Dallas, Texas 75265

EVM WARNINGS AND RESTRICTIONS

It is important to operate this EVM within the input voltage range of 5 V and the output voltage range of 5 V.

Exceeding the specified input range may cause unexpected operation and/or irreversible damage to the EVM. If there are questions concerning the input range, please contact a TI field representative prior to connecting the input power.

Applying loads outside of the specified output range may result in unintended operation and/or possible permanent damage to the EVM. Please consult the EVM User's Guide prior to connecting any load to the EVM output. If there is uncertainty as to the load specification, please contact a TI field representative.

During normal operation, some circuit components may have case temperatures greater than 55°C. The EVM is designed to operate properly with certain components above 55°C as long as the input and output ranges are maintained. These components include but are not limited to linear regulators, switching transistors, pass transistors, and current sense resistors. These types of devices can be identified using the EVM schematic located in the EVM User's Guide. When placing measurement probes near these devices during operation, please be aware that these devices may be very warm to the touch.

Mailing Address:

Texas Instruments
Post Office Box 655303
Dallas, Texas 75265

Contents

1	Description	1-1
1.1	Block Diagram	1-2
1.2	Connectors and Jumpers	1-2
1.3	Switch Settings	1-2
1.4	LED Monitor	1-2
2	Schematic and Printed-Circuit Board	2-1
2.1	DEM-PCM2901/2903 Printed-Circuit Board	2-2
2.2	DEM-PCM2901/2903 Schematic	2-4

Figures

1-1	DEM-PCM2901/2903 Block Diagram	1-2
2-1	DEM-PCM2901/2903 Silkscreen	2-2
2-2	DEM-PCM2901/2903 Top View	2-2
2-3	DEM-PCM2901/2903 Bottom View	2-3
2-4	DEM-PCM2901/2903 Schematic	2-4

Description

The DEM-PCM2901 and DEM-PCM2903 are evaluation boards for Texas Instruments' newly developed USB interface codecs, PCM2901 and PCM2903. The DEM-PCM2901 includes a PCM2901. It is a self-powered USB codec without an S/PDIF interface. The DEM-PCM2903 includes a PCM2903. It is a self-powered USB codec with an S/PDIF interface.

A USB connector is mounted on the DEM-PCM2901/2903. Connecting a USB interface to this USB connector enables the evaluation of codec performance.

The DEM-PCM2901/2903 requires a 5-V power supply for the codec and S/PDIF sections and a 5-V power supply for the analog input/output amplifier section.

Stereo audio output is available on two RCA jacks.

The PCM2901/2903 supports the following USB features:

- Fully compliant with the USB 1.1 specification
- Full-speed transceivers
- Partially programmable descriptors
- USB adaptive mode for playback
- USB asynchronous mode for record
- Self-powered

Topic	Page
1.1 Block Diagram	1-2
1.2 Connectors and Jumpers	1-2
1.3 Switch Settings	1-2
1.4 LED Monitor	1-2

1.1 Block Diagram

Figure 1–1. DEM-PCM2901/2903 Block Diagram

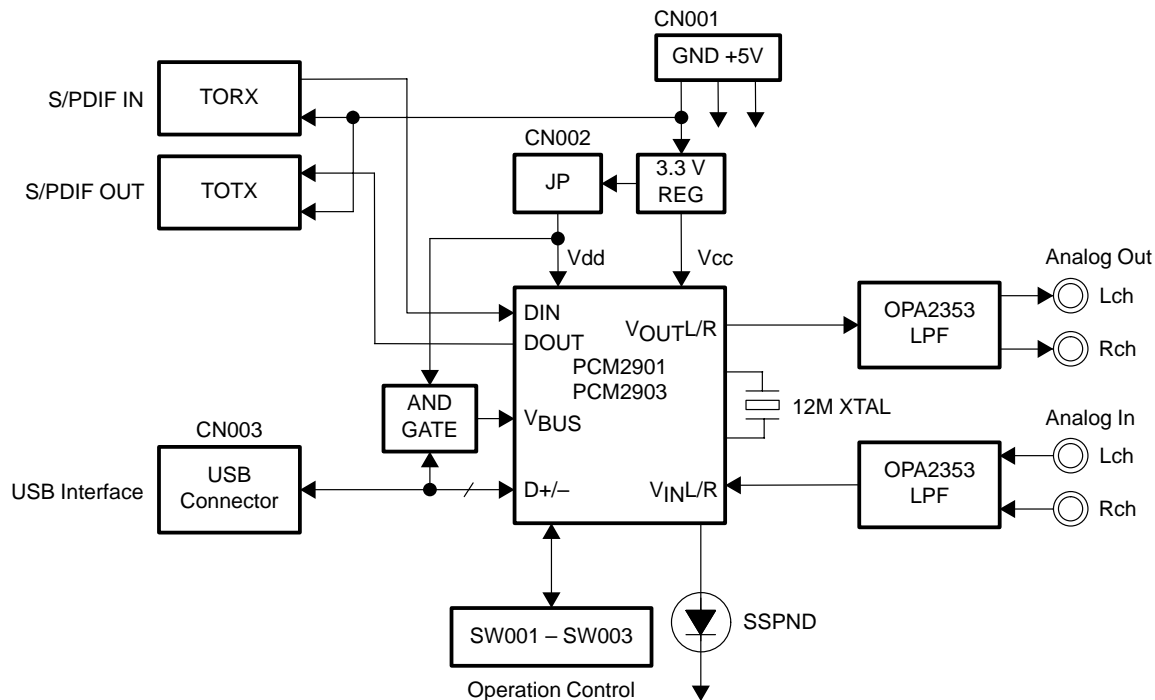

1.2 Connectors and Jumpers

- CN001 : Power supply, 5 V
- CN002 : Jumper (connecting regulated 3.3 V)
- CN003 : USB port (series B connector), connects to USB cable/connector
- CN101, CN102 : Audio LINE OUT (RCA, 1.98 V_{PP} full scale)
- CN103, CN104 : Audio LINE IN (RCA, 1.98 V_{PP} full scale)
- U002 : S/PDIF In (DEM-PCM2903 only)
- U003 : S/PDIF Out (DEM-PCM2903 only)

1.3 Switch Settings

- SW001: HID key state (mute)
- SW002: HID key state (volume up)
- SW003: HID key state (volume down)

These switches should be set to LOW logic level for software control, or toggled HIGH for manual control of their respective parameters.

1.4 LED Monitor

- D001 (Red): Indicates suspend state

Schematic and Printed-Circuit Board

This chapter presents the DEM-PCM2901/2903 printed-circuit board and schematic.

Topic	Page
2.1 DEM-PCM2901/2903 Printed-Circuit Board	2-2
2.2 DEM-PCM2901/2903 Schematic	2-4

2.1 DEM-PCM2901/2903 Printed-Circuit Board

Figure 2–1. DEM-PCM2901/2903 Silkscreen

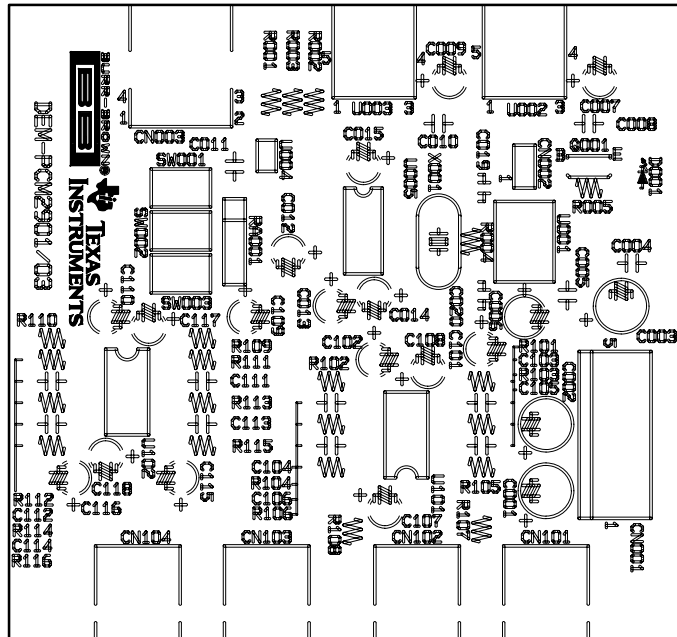

Figure 2–2. DEM-PCM2901/2903 Top View

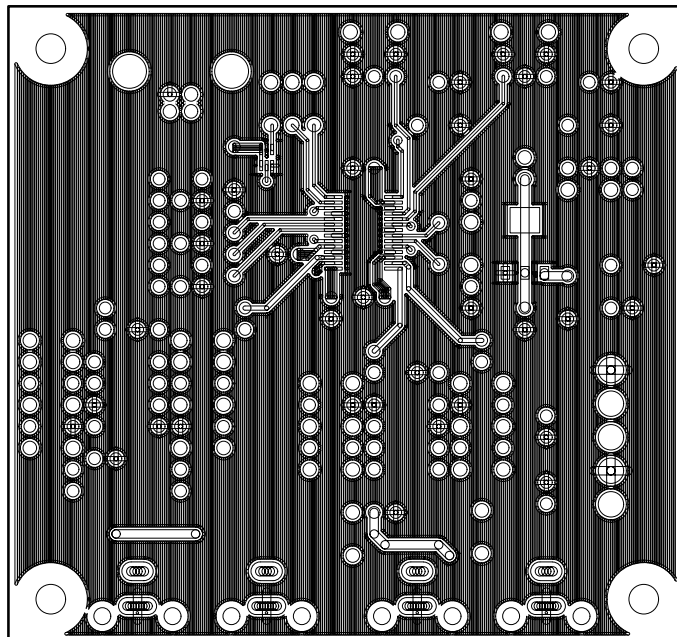
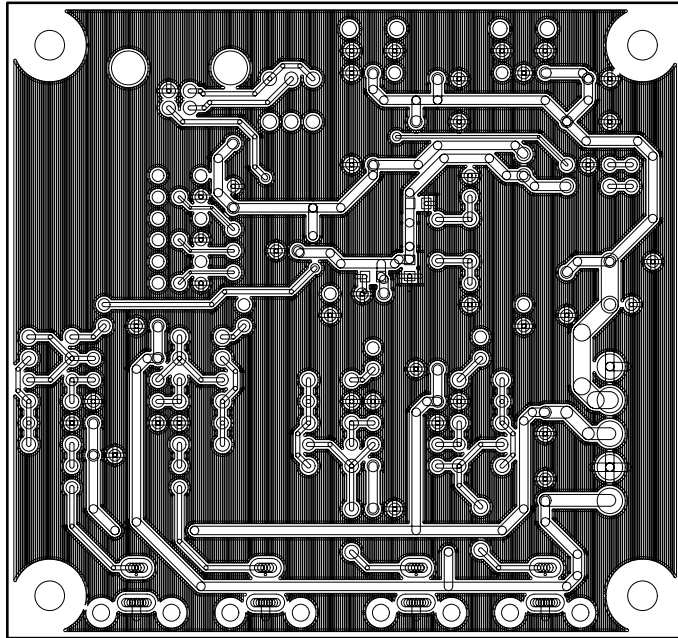
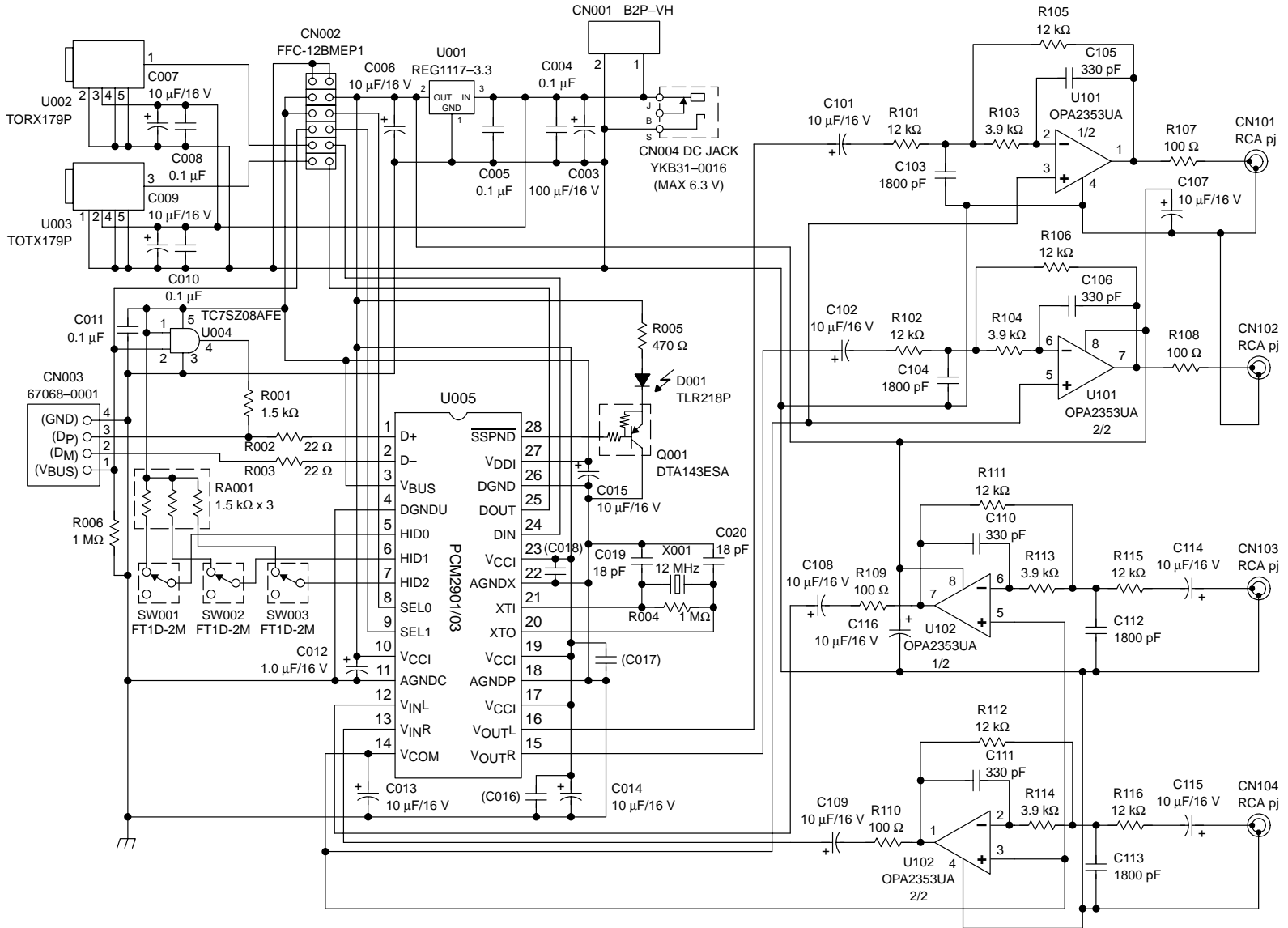

Figure 2-3. DEM-PCM2901/2903 Bottom View



2.2 DEM-PCM2901/2903 Schematic

Figure 2-4. DEM-PCM2901/2903 Schematic



NOTE: On the PCM2901, pin 24 and pin 25 are test pins.