

Charlie Ice,
G2000 MCU Marketing Manager;
Bilal Akin,
Systems Application Engineer;
Texas Instruments

Executive summary

Digital motor control was first introduced to overcome the challenges that traditional analog systems had in handling drift, aging of components and variations caused by temperature. Flexible software algorithms not only eliminated tolerance issues relating to components, they enabled developers to dynamically accommodate variations in environmental conditions over time. For example, rather than only being able to turn a fan motor full on or off, with a digital implementation, fan speed can now be adjusted based on system temperature. Additionally, systems can calibrate themselves, thus eliminating the need to schedule regular, manual maintenance.

This paper provides an overview of motor control design considerations, such as control of multiple motors, field-oriented control, power factor correction and sensorless control. It also addresses how today's microcontrollers (MCUs) bring even greater precision, power efficiency and reduced cost to a wide range of applications.

Designing High-Performance and Power-Efficient Motor Control Systems

Today's microcontrollers (MCUs) bring even greater precision, power efficiency and reduced cost to a wide range of applications, including:

- White goods and appliances with blowers and compressors such as washers and refrigerators
- HVAC (Heating, Ventilation and Air Conditioning) systems
- Industrial servo drives used for motion control, power supply inverters and robotics
- Automotive control systems, including power steering, anti-lock brakes and suspension controls

TI understands the challenges developers face in designing these high-performance motor control systems. Manufacturers seek to introduce advanced control algorithms to differentiate their products, and increasing government regulation requires more efficient power consumption and reduced EMI.

To aid developers in meeting these diverse challenges, TI offers the TMS320C2000™ Piccolo™ MCU series. Piccolo MCUs have an optimized architecture integrating specialized peripherals that:

- Enable the use of real-time algorithms for more precise and accurate control
- Yield better power efficiency and control through power factor correction (PFC)
- Support control of multiple motors with a single chip
- Simplify design through sensorless control
- Reduce system complexity and cost

The Piccolo advantage

Leveraging TI's high-performance TMS320C28x™ core, Piccolo MCUs provide all of the necessary performance and peripherals needed to control a system with a single stand-alone controller. With its ample headroom and specialized peripherals, Piccolo MCUs enable developers to implement more advanced control algorithms to further improve performance while lowering system cost.

The Piccolo™ architecture has been optimized for digital control applications with advanced architectural features to enhance high-speed signal processing. Piccolo's main CPU core has built-in DSP capabilities such as a single cycle 32×32-bit multiply and accumulate unit, which greatly speeds computations. Furthermore, the control peripherals, such as the ADC and PWMs, are designed to be very flexible and easily adapt to almost any use, requiring very little software overhead. For example, the A/D converter has an auto-sequencer which developers can program to cycle through samples in a specific order so that values are ready when the application needs them. With more intelligent control peripherals and a powerful CPU core, control loops run tighter, both improving the dynamic nature of control algorithms and resulting in better disturbance behavior.

The integrated Control Law Accelerator (CLA) on the TMS320F2803x Piccolo MCUs is a 32-bit floating-point math accelerator that effectively offloads high-speed control loops from the main CPU core. The CLA achieves this through its direct access to peripherals and its ability to respond to peripheral interrupts without having to go through the CPU core. Similar to an independent core, the CLA has its own instruction set and memory space, allowing it to operate completely independent of the CPU.

Other important Piccolo MCU features include:

- Single 3.3-V supply for full operation
- Dual-internal, high-precision oscillators; no external crystal necessary
- 12-bit A/D converter with 16 channels and a maximum sampling frequency of 4.6 mega-samples per second
- 14 channels of PWM output with configurable automatic dead band
- Seven (7) of the 14 PWM channels can operate in high-resolution mode with a resolution as low as 150 picoseconds
- Enhanced Quadrature Encoder Pulse (QEP) and Enhanced Capture Peripheral (eCAP) for simplified sensor decoding.

Precise and accurate control

The Piccolo architecture provides impressive processing capacity, in the range of 40 to 60 millions of instructions per second (MIPS). Such high performance allows developers to not only concurrently monitor and control multiple motors but to execute more complex control algorithms for higher accuracy, smoother performance and better power consumption. For example, a single Piccolo MCU is capable of controlling two motors while maintaining active PFC control and still has sufficient processing capacity for implementing advanced motor-control algorithms such as sensorless field-oriented control (FOC).

Pulse Width Modulation (PWM) plays an important role in generating the voltage or current required to feed motors or high-performance power supplies. Recent improvements in control algorithms enable developers to implement highly accurate algorithms providing dynamic control that adapts to real-time variations

in system behavior. FOC offers many benefits, including full motor torque capabilities at low speeds, excellent dynamic behavior, higher efficiency across a wide speed range, decoupled control of torque and flux, short-term overload capabilities and four-quadrant operation. However, FOC also requires substantially more complex calculations than standard control schemes.

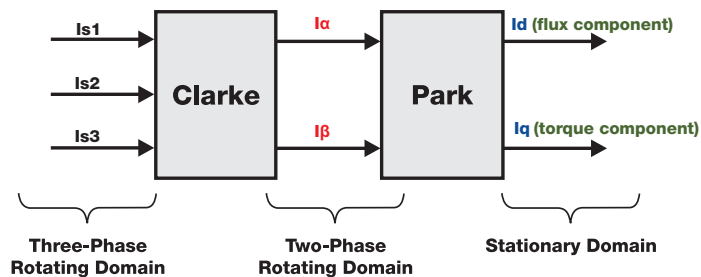

Figure 1. Combining the CLARKE and PARK transforms as defined above, we move from the three-phase rotating domain to the stationary domain: we just need to control DC quantities in real-time.

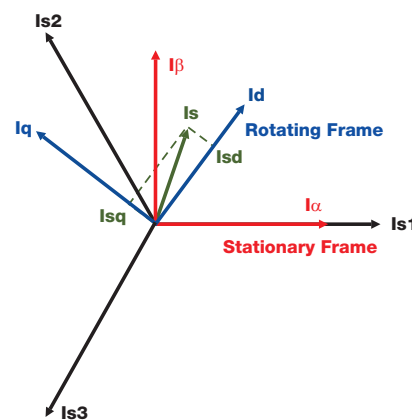

Figure 2. Stator current vector decoupling into torque and flux components in order to implement field-oriented control.

The FOC principle consists of controlling the angle and amplitude components of the stator field by sampling the motor's phase currents and then transforming them such that they can be conveniently controlled. The three-phase currents of the motor are read into the system via an ADC. These phase currents are in a three-phase rotating domain and are transformed into a two-dimensional rotating domain using the Clarke transform. From here, the two phases can be transformed onto a stationary domain using the Park transform, as shown in Figure 1. The Clarke and Park transforms can be visualized as vector projections onto one another, as shown in Figure 2. The Park transform yields I_d , the flux component, and I_q , the torque component. The motor torque for a permanent magnet motor depends only on the torque component, I_q . Thus, the most convenient control strategy is to set the flux component (I_d) to zero, which minimizes the torque vs. current ratio and increases the motor efficiency. The control of current components requires the knowledge of the instantaneous rotor position. The rotor position can either be calculated using sensorless techniques or

Power factor correction

PFC makes sure the current waveform follows the voltage waveform and also regulates the output DC voltage to a constant value regardless of any changes in the load or the input conditions. When PFC is implemented in an active, digital fashion, it can be more precise and eliminate any phase shift between voltage and current. Reducing the harmonic current content is desirable because this represents reactive power that is drawn and not used. The significance of power factor lies in the fact that utility companies supply customers with volt-amperes, but bill them for watts. Power factors below 1.0 require a utility to generate more than the minimum volt-amperes necessary to supply the real power (watts).

Among other things, PFC serves to smooth out power draw and regulate the output voltage. For example, when the compressor in a refrigerator turns on, it can place a huge load on the power grid that typically manifests as a voltage drop. Such power spikes and harmonics can damage fragile electronics systems. When systems spike, without PFC they tend to draw power they don't consume, reducing overall efficiency. Additionally, PFC keeps the DC bus voltage stabilized even under dynamic loadings.

PFC also has an impact further down the power chain. Since power companies need to be able to generate greater power capacity to accommodate spikes, electronics manufacturers have been encouraged to employ technologies such as PFC to smooth out power draw. In some cases, PFC has been mandated – IEC 60730 requires PFC in white goods to be sold in European markets.

Analog or passive implementations of PFC are locked into a single mode and have a limited ability to react to changes in operating conditions. Active or digitally controlled PFC, in contrast, can act on and adapt to changes in operating conditions. For example, when an air conditioning is about to turn on its compressor, PFC can actively compensate for the larger load as it hits. This not only reduces the number of transients generated, but also results in more efficient power usage. The flexibility of digital PFC also enables developers to employ more complex PFC topologies than is possible with passive implementations.

The importance of high-resolution PWMs and A/D converters for effective PFC cannot be underestimated. Maintaining the integrity of signals where the analog and digital domains meet is of extreme importance as any error introduced at these junctions will degrade performance.

Control of multiple motors

Many systems utilize more than one motor. For example, an HVAC system has to manage both a compressor and fan. Most implementations require separate controllers for each motor and another to implement PFC.

The C2000™ Piccolo™ MCU is the first controller capable of managing two motors with PFC using a single chip. Many MCUs do not have the computational capacity or integrated peripherals required to control multiple motors and implement active PFC. Controlling a motor, for example, might require a control loop operating with a frequency of up to 20 KHz. PFC, on the other hand, requires an operating frequency on the order of 50 to 100 KHz. In order to reliably implement such high-frequency control algorithms – in this case, two controlling motors and one managing PFC – an MCU must be able to process computations quickly and efficiently with little latency.

The ability to control multiple motors not only reduces system cost but improves overall power efficiency and performance. For applications that operate dual motors, the fact that both motors are controlled by the same MCU enables the controller to coordinate how quickly it ramps one motor up relative to the speed of the other. In addition, since both motors draw from the same current source, the PFC implementation can be coordinated as well for better results.

Sensorless control

Another area of potential cost savings is that of sensorless feedback. Rather than employing speed and/or position sensors, modeling techniques can be used accurately determine motor position or speed. To control PM brushless DC motors, position and speed information is critical. In many of today's systems, sensors are used to gather this data as inputs to the control algorithm. However, these sensors are undesirable from standpoints of size, cost, maintenance and reliability.

For some applications, sensors will be absolutely necessary. An oxygen pump for a hospital ventilator, for example, needs sufficient precision to guarantee a set flow rate. In cases where a custom motor is being used, it may be too difficult to create an accurate model. For very-low-speed systems applications, there may be not enough feedback to support a sensorless implementation.

For many applications however, including white goods, such precision is unnecessary, so sensorless control can be introduced to reduce system cost. For example, when permanent magnet synchronous motors are in use, sensors can be replaced by a dynamic model called a sliding mode observer which is both robust and straightforward to implement. In addition, high power efficiency can be achieved with extremely low worst-case speed error.

Eliminating sensors requires that the controller model the state of the motor so that the corresponding position/speed can be properly estimated. In order to maintain sufficient accuracy of the model, precise, high-frequency monitoring of voltages is required. For this job, Piccolo™ MCUs offer an integrated 12-bit A/D converter, which offers the right level of accuracy for most applications.

For those applications that do require sensors, Piccolo MCUs are designed to support quadrature encoders and tachogenerators. For applications requiring an encoder, Piccolo devices include an integrated Enhanced Quadrature Encoder Pulse (QEP) which automatically converts optical encoder pulses into speed and direction while using only two digital inputs and a 16-/32-bit internal timer register. The QEP is another example of TI's commitment to accelerate development by reducing system complexity. By automatically handling decoding of pulses and outputting position and speed, the QEP frees developers from having to create this code themselves and enables them to focus on differentiating their application.

Piccolo MCU's QEP is especially versatile in that it can interface to virtually any quadrature encoder, including those which require a clock signal, those which generate their own, and those which do not use a clock. MCUs without a QEP require developers to capture pulses using GPIO and then decode them in software in a manner which complicates maintaining the real-time reliability of high-frequency control loops.

There are various types of tachogenerators; some provide a DC voltage proportional to the motor speed. This speed can be easily calculated by connecting one of the Piccolo™ MCU's A/D converter inputs to the tachogenerator output. For low-cost motors that use a simple Hall Effect sensor to output a number of pulses per motor revolution, typically a software driver measures the frequency of the pulses and also tracks motor direction.

A Piccolo MCU simplifies the design of this software driver through the use of its integrated Enhanced Capture Peripheral (eCAP). The eCAP triggers off of the rising or falling edge of the Hall Effect pulse and automatically calculates the width and period between pulses. In addition, the eCAP can capture up to four pulses before needing to be read.

Driving down system cost

The ideal system merges analog and digital technology in a way that leverages the available processing capacity for a given price point.

One of the key foundations behind the Piccolo MCU architecture is the amount of functionality that is integrated onto a single chip. By performing tasks in the digital domain, component count can be reduced. This directly reduces system cost and improves reliability. The trade-off is that the MCU has to be capable of cost-effectively absorbing the added load.

Efficient control across all speed ranges enables developers to design power device circuits to optimally match the capacity and needs of the applications, increasing power and cost efficiency. This also results in smoother operation and better performance that reduces issues such as torque ripple and vibration that can impact operating life.

For sensorless applications, the cost savings can be significant. In addition to removing these sensors from the system BOM, going sensorless also eliminates the need to install interfaces to the sensors. Not only are systems cheaper to manufacture, there are fewer points of failure.

The value of self-monitoring also extends far beyond simply migrating formerly analog functions to a digital implementation. The availability of 16 A/D channels, coupled with a programmable auto-sequencer, simplifies the process of monitoring different currents, voltages and sensors throughout the system. The same data used to increase the precision and performance of a motor can be exploited to diagnose potential problems as well. For example, by observing the frequency spectrum of mechanical vibrations, the system can recognize, predict, and act upon system failure conditions when they are in their early stages.

Unparalleled development platform

Creating robust digitally controlled systems has never been easier. TI's Motor Control and PFC Developer's Kit as well as the Dual-Motor Control and PFC Developer's Kit are based on Piccolo MCUs to give developers a platform that accelerates development and troubleshooting of motor control systems. The intuitive kits even teach developers unfamiliar with PFC how to merge PFC with motor control applications of all types.

The Motor Control and PFC kits provide direct access to all of the enhancements and features of the Piccolo™ architecture. Extensive software libraries and thorough documentation lead developers through the process of creating a complete motor control system utilizing real-time algorithms. The kit also enables developers to determine quickly the processing resources required to implement basic motor control. From this baseline, they are then able to bring in advanced algorithms to trade-off the remaining processing capacity for greater accuracy, better performance, higher power efficiency, control of multiple motors and a myriad of other options. In this way, developers can architect systems specifically optimized for their application constraints and requirements.

C2000™ Piccolo MCUs are available across a wide roadmap of configurations to ensure that developers can find a processor optimized in terms of performance, memory, and peripherals for their application. TI also supplies all the analog components necessary for voltage and current sensing, as well as a wide range of standard and advanced motor drivers.

TI understands the challenges developers face when designing cost-effective and power-efficient motor control applications. With the Piccolo series of MCUs, TI has brought together an unparalleled combination of high performance and integrated peripherals, enabling developers to implement dual motor control using a single processor with enough headroom for precision control algorithms, advanced power efficiency, and sensorless feedback, all while reducing system cost.

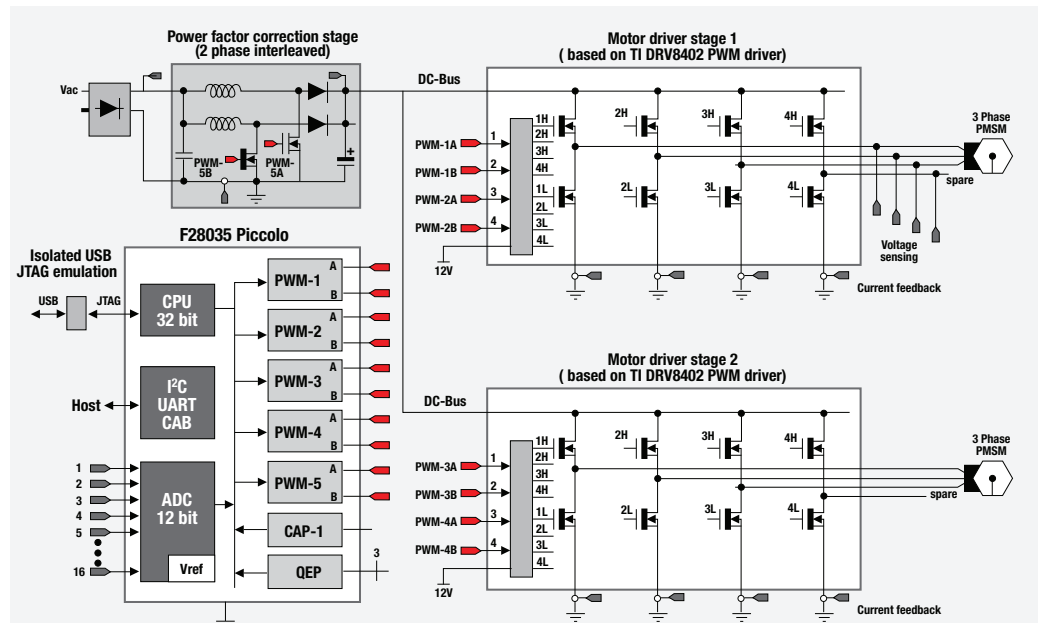

Figure 4. TI's Motor Control and PFC Developer's Kit block diagram.

Find out more about TI's MCU portfolio and motor control solutions by visiting the links below:

- [Motor Control and PFC Developer's Kits](#)
- [TI eStore](#)
- [Sign up for TI MCU newsletters and other information](#)
- [TI's Piccolo™ MCUs](#)
- [Piccolo one-day workshop](#)
- [TI's microcontrollers](#)
- [MCU tools videos](#)
- [TI E2E MCU community](#)

Important Notice: The products and services of Texas Instruments Incorporated and its subsidiaries described herein are sold subject to TI's standard terms and conditions of sale. Customers are advised to obtain the most current and complete information about TI products and services before placing orders. TI assumes no liability for applications assistance, customer's applications or product designs, software performance, or infringement of patents. The publication of information regarding any other company's products or services does not constitute TI's approval, warranty or endorsement thereof.

TMS320C2000, C2000, Piccolo are trademarks of Texas Instruments Incorporated. All other trademarks are the property of their respective owners.

IMPORTANT NOTICE

Texas Instruments Incorporated and its subsidiaries (TI) reserve the right to make corrections, modifications, enhancements, improvements, and other changes to its products and services at any time and to discontinue any product or service without notice. Customers should obtain the latest relevant information before placing orders and should verify that such information is current and complete. All products are sold subject to TI's terms and conditions of sale supplied at the time of order acknowledgment.

TI warrants performance of its hardware products to the specifications applicable at the time of sale in accordance with TI's standard warranty. Testing and other quality control techniques are used to the extent TI deems necessary to support this warranty. Except where mandated by government requirements, testing of all parameters of each product is not necessarily performed.

TI assumes no liability for applications assistance or customer product design. Customers are responsible for their products and applications using TI components. To minimize the risks associated with customer products and applications, customers should provide adequate design and operating safeguards.

TI does not warrant or represent that any license, either express or implied, is granted under any TI patent right, copyright, mask work right, or other TI intellectual property right relating to any combination, machine, or process in which TI products or services are used. Information published by TI regarding third-party products or services does not constitute a license from TI to use such products or services or a warranty or endorsement thereof. Use of such information may require a license from a third party under the patents or other intellectual property of the third party, or a license from TI under the patents or other intellectual property of TI.

Reproduction of TI information in TI data books or data sheets is permissible only if reproduction is without alteration and is accompanied by all associated warranties, conditions, limitations, and notices. Reproduction of this information with alteration is an unfair and deceptive business practice. TI is not responsible or liable for such altered documentation. Information of third parties may be subject to additional restrictions.

Resale of TI products or services with statements different from or beyond the parameters stated by TI for that product or service voids all express and any implied warranties for the associated TI product or service and is an unfair and deceptive business practice. TI is not responsible or liable for any such statements.

TI products are not authorized for use in safety-critical applications (such as life support) where a failure of the TI product would reasonably be expected to cause severe personal injury or death, unless officers of the parties have executed an agreement specifically governing such use. Buyers represent that they have all necessary expertise in the safety and regulatory ramifications of their applications, and acknowledge and agree that they are solely responsible for all legal, regulatory and safety-related requirements concerning their products and any use of TI products in such safety-critical applications, notwithstanding any applications-related information or support that may be provided by TI. Further, Buyers must fully indemnify TI and its representatives against any damages arising out of the use of TI products in such safety-critical applications.

TI products are neither designed nor intended for use in military/aerospace applications or environments unless the TI products are specifically designated by TI as military-grade or "enhanced plastic." Only products designated by TI as military-grade meet military specifications. Buyers acknowledge and agree that any such use of TI products which TI has not designated as military-grade is solely at the Buyer's risk, and that they are solely responsible for compliance with all legal and regulatory requirements in connection with such use.

TI products are neither designed nor intended for use in automotive applications or environments unless the specific TI products are designated by TI as compliant with ISO/TS 16949 requirements. Buyers acknowledge and agree that, if they use any non-designated products in automotive applications, TI will not be responsible for any failure to meet such requirements.

Following are URLs where you can obtain information on other Texas Instruments products and application solutions:

Products

Amplifiers	amplifier.ti.com
Data Converters	dataconverter.ti.com
DLP® Products	www.dlp.com
DSP	dsp.ti.com
Clocks and Timers	www.ti.com/clocks
Interface	interface.ti.com
Logic	logic.ti.com
Power Mgmt	power.ti.com
Microcontrollers	microcontroller.ti.com
RFID	www.ti-rfid.com
RF/IF and ZigBee® Solutions	www.ti.com/lprf

Applications

Audio	www.ti.com/audio
Automotive	www.ti.com/automotive
Broadband	www.ti.com/broadband
Digital Control	www.ti.com/digitalcontrol
Medical	www.ti.com/medical
Military	www.ti.com/military
Optical Networking	www.ti.com/opticalnetwork
Security	www.ti.com/security
Telephony	www.ti.com/telephony
Video & Imaging	www.ti.com/video
Wireless	www.ti.com/wireless

Mailing Address: Texas Instruments, Post Office Box 655303, Dallas, Texas 75265
Copyright © 2009, Texas Instruments Incorporated