

## Product Bulletin

# TMS320DRI200 Digital Baseband

Texas Instruments (TI) and iBiquity Digital Corporation, the sole developer and licensor of digital AM and FM broadcast technology in the U.S., have developed the first baseband solution for HD Radio™ for radio receiver manufacturers. Available today, the HD Radio solution includes:

- TI's TMS320DRI200 DSP-based digital baseband chip
- iBiquity's DRI200-based In-Band On-Channel (IBOC) Digital Module (IDM)

The DRI200 handles all of the baseband processing required for HD Radio making commercial HD Radio a reality for home and automotive applications.

## Digital Baseband and Receiver System

As the industry's first digital baseband to support iBiquity's HD Radio, TI's new single chip, TMS320DRI200, enables receiver manufacturers to design and deliver HD Radio

receivers in 2003. TI's DRI200 chip incorporates digital channel source, data decoding and demodulation functions (see Figure 1). Features include:

- Compatible with iBiquity's IBOC digital AM/FM system
- On-chip data decoding
- Compatible with standard audio DAC interfaces
- Can interface to external micro-controller, DRAM and SRAM
- JTAG emulation

### Key Benefits

- **Fast time-to-market** – Available today, the DSP-based solution enables receiver manufacturers to deliver HD Radio™ in 2003
- **Low risk** – With evolving standards, changes can be made easily in software
- **Enables product integration** – Software approach offers ability to quickly and easily create integrated and innovative products
- **Low-cost roadmap** – DRI200 chipset lowers system cost and shrinks form factor

Figure 1. Digital Baseband System

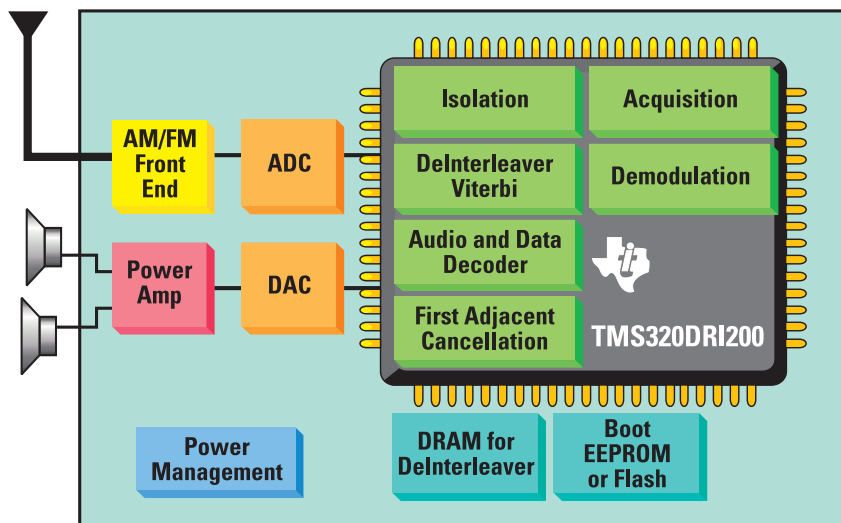

Figure 1. The TMS320DRI200 implements the baseband processing for HD Radio on a single device.

**Figure 2. IBOC Digital Module**



Showing the small form factor, Figure 2 depicts the IBOC Digital Module (IDM) and the single-chip baseband. This small form factor will be necessary for home and automotive applications.

- -40 to 85°C operation

The IDM combines the memory and appropriate interfaces on a credit-card-size board (see Figure 2). Designed by iBiquity, the IDM reduces complexity of a HD Radio™ receiver and helps reduce development and deployment time for radio manufacturers. The IDM is designed to plug into existing AM/FM radio manufacturers.

### TI's Software Advantage

TI's DRI200 solution is based on a programmable TMS320C64x™ DSP core. This approach provides three major advantages:

- **Little design risk** – With an emerging standard such as HD Radio, changes can be easily

accommodated in software versus stopping development to redesign and fabricate a new hardwired ASIC.

- **Fast time-to-market** – Available today, the industry's first HD Radio baseband enables receiver manufacturers to deliver digital AM/FM radios in 2003.
- **More differentiation** – Adding customer-owned software or innovative features (such as MP3 decode) can be easily integrated to the HD Radio through software.

### Availability and Pricing

The IDMs from iBiquity based on the DRI200 baseband are available now to licensed radio receiver manufacturers. The DRI200 samples are available now at U.S.\$50\* per unit and production volumes are expected 4Q02.

For more information, please contact the nearest TI sales office or visit our web site at:

<http://www.ti.com/sc/digitalradio>

**Figure 3. HD Radio Solution**

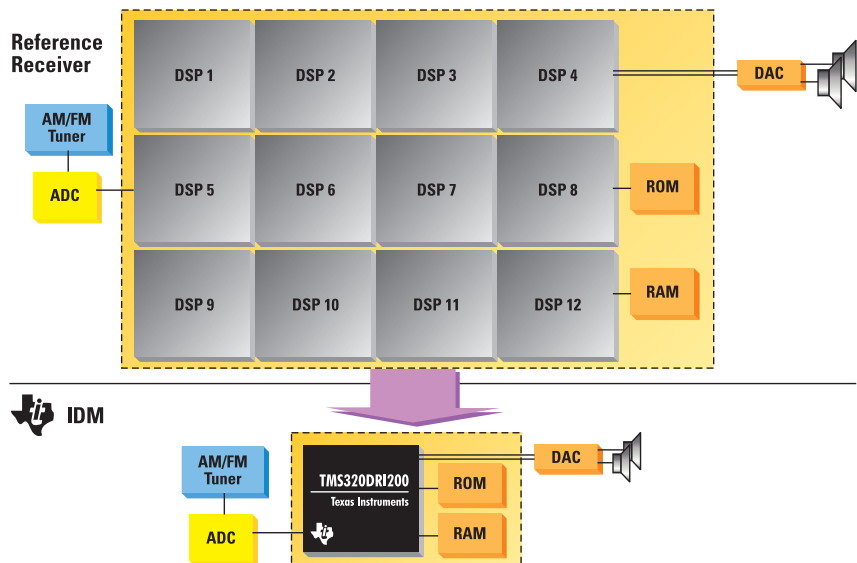

Figure 3 shows the difference between the IBOC reference receiver, based on 12 DSPs (for baseband demodulation and decoding), and the IDM based on the TMS320DRI200. This integration of performance is critical for driving down cost and helping commercial HD Radio receivers become reality.

\*All prices are 2002 suggested retail price in U.S. dollars and subject to change.



Real World Signal Processing, the black/red banner and TMS320C64x are trademarks of Texas Instruments. HD Radio is a trademark of iBiquity Digital Corporation.