

# OMAP™ processor for e-readers

OMAP™ 3  
Processors  
OMAP3621



**TI's second generation of e-readers includes a new software electrophoretic display (EPD) controller-based solution that allows customers to differentiate, innovate and create the ultimate user experience.**

## Product Bulletin

### **Overview**

TI's latest OMAP36xx application processor is the first well-proven, high-performance, 800-MHz Cortex-A8-based solution for e-readers using a software EPD controller. It will allow designers to deliver an outstanding user experience so that consumers can use e-books in new ways.

### **Differentiate and innovate**

TI's powerful E Ink-certified DSP software EPD controller is implemented in such a way that it can support multiple types of displays. Compared to non-upgradable fixed hardware solutions (which do not allow for differentiation), the ability to bring constant updates and customizations to the software controller is a powerful weapon that allows our customers to stay on top of technology and market needs.

### **Improved system cost**

TI's OMAP3621 has been designed to address the trade-off between cost and performance. Our goal is to satisfy our customers' need for sleek and modern designs while improving power consumption and user experience. Using low-power DDR, a smaller package allows our customers to create a very lightweight, thin modern and low-power-consumption device that will satisfy even the most demanding consumers.

### **Performance**

- Resolutions supported:
  - 2,048 x 1,536 (QXGA) at 106 Hz
  - 3,200 x 2,048 (WQSXGA) at 50 Hz
- Unlimited number of regional updates for impressive animations and differentiated UIs
- Dual-screen support:
  - EPD and EPD
  - EPD and LCD
- Software flexibility to adapt to any sudden technology changes such as new color technologies
  - Capability to drive any EPD color, high-resolution or large flexible displays
  - Faster PDF launch times than any other ARM9-/ARM11-based processors

### **Manufacturing capabilities**

TI's reputation makes it a trustworthy supplier that can deliver high-quality products in large quantities.

### **Extended battery life**

Battery life is the No. 1 top priority for end customers. TI's well-proven, best-in-class power management techniques have satisfied the Smartphone market for many years. Our well-proven experience, when brought to the consumer market, improves the overall user experience.

### **E-readers support structure**

TI's consumer business line offers a strong baseline of support, reinforced by trained FAEs around the world. We believe that high-quality products are developed with high-quality support.

### **High-quality analog**

TI's e-book development platform incorporates high-quality analog devices. Many analog devices have been optimized to best interact with each other, further optimizing platform performance and overall product quality. TI's wide analog portfolio allows customers to customize their platforms.

### **E Ink-certified software EPD controller**

TI's OMAP™ 3 e-book solution employs a unique DSP-based software controller to drive E Ink's Vizplex electrophoretic displays whether they are black and white or color.

### OMAP3611 PDF performance

#### (Cortex-A8 running at 600 MHz only)

Benchmark conducted on three PDF files stored on an SD card and rendered, scaled and displayed on 16 levels of grayscale (4-bit) monochrome display. Decoding done on Cortex-A8, with no specific hardware acceleration or optimizations.

### New EPD controller software version 2

- EPD controller software version 2
  - Unlimited partial update: software can re-write in a “zone” being updated
  - Per-pixel driving : mouse pointer, fast menu, easy handwriting
  - Keeps software compatibility with version 1 controller
  - Flexibility to be updated (OTA)/improved
  
- What it will mean for OEMs
  - Ease of programming to best take advantage of the software EPD controller
  - Simple API
  - Non-EPD-aware applications will perform well with the software EPD controller using generic API
  - EPD-aware applications can use dedicated API for best-in-class effects
  
- What it will mean for end users
  - Smoother and improved user interface
  - More applications can be addressed
  - Handwriting recognition
  - Virtual keypad with visual feedback
  - Animations
  - Games
  
- Why it's better than the current hardware controller
  - Flexibility to adapt any type of panel and features (EIH V110, V220, V250, next gen, LG GIP)
  - Software flexibility for color processing
  - No limitations to concurrent regional updates



- Improved UI responsiveness
- Higher quality
- Improved battery life
- Instant on/off
- Allows ultra-slim and light designs
- Very fast page turns
- Color support for next-generation E Ink displays

▲ PDF rendering and profiling using the software EPD controller

	User's guide	Texas Instruments TRM	EDN magazine
	13,300 KB – color (202 pages)	76,000 KB – black and white (6,609 pages – text with pictures)	16,500 KB – color, ads and text (66 pages – complex document)
File opening time (first page displayed)	2.1 seconds	2.1 seconds	3 seconds

### Advanced power management at SoC levels

TI OMAP technology is divided into eight distinct physical power domains, which can be separately enabled or disabled by software. TI's SmartReflex™ intelligent technology includes improved software techniques that can be divided into two main categories:

- **Active power management.**  
Power consumed by the switching activities in the circuits involves all system components: hardware modules, device drivers, OS and applications. It employs three main techniques: adaptive voltage scaling (AVS), dynamic power switching (DPS) and dynamic voltage and frequency scaling (DVFS).

- **Static leakage management.**  
Leakage because of lower process nodes is always present, even when no logic operations are performed. We have introduced a technique called static leakage management to reduce this leakage.

SmartReflex technologies	Description
Adaptive voltage scaling (AVS)	Maintains high performance while minimizing voltage based on silicon process and temperature.
Dynamic power switching (DPS)	Dynamically switches modules from active state to retention or off-state mode when computational tasks are completed and not needed at the moment.
Dynamic voltage and frequency scaling (DVFS)	Dynamically adjusts voltage and frequency to adapt to the performance required.
Static leakage management (SLM)	Reduces leakage power by switching the entire device into a low-power mode when no system activity is required. Relies on several power modes, from standby to power off mode.

**Lower system cost approach**

**At the platform level:**

In this fast-changing and evolving market, flexibility and reusability have been critical to the success or failure of many OEMs/ODMs. TI's e-book development system approach is software-optimized and ready to address the development of multiple products based on the same core design (i.e., multimedia e-readers/tablets), allowing you to achieve important cost savings.

- Cost reduction by design and R&D savings:
  - Multiple product development (concept/architecture-phase savings)
  - Assurance of high-quality devices and high-quantity deliveries
  - Software investments can be reused between products
  - Retain the benefits of previous development experiences and optimizations
  - Ready vehicle for fast time-to-market product development

**At the system level:**

TI has been the first to introduce a more optimized and high-performing architecture to enable wide adoption of e-readers while improving the overall user experience. Compared to the first-generation architecture, TI's new architecture enables:

- More flexibility
- Lower e-BOM cost
- Higher performance
- Slim and lightweight designs

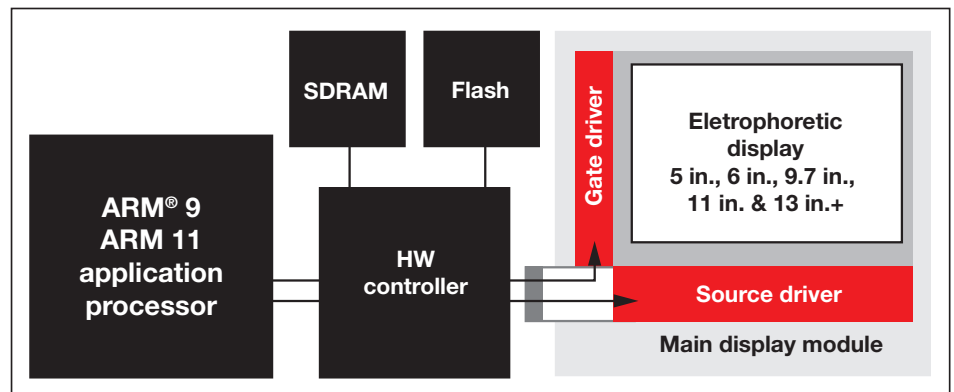

▲ Competitor's old generation of e-reader devices

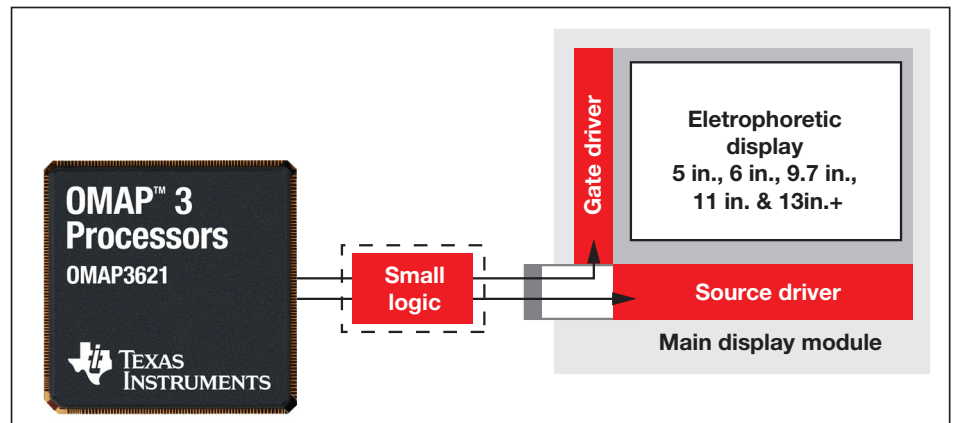

▲ TI's new generation of e-reader devices

**Important Notice:** The products and services of Texas Instruments Incorporated and its subsidiaries described herein are sold subject to TI's standard terms and conditions of sale. Customers are advised to obtain the most current and complete information about TI products and services before placing orders. TI assumes no liability for applications assistance, customer's applications or product designs, software performance, or infringement of patents. The publication of information regarding any other company's products or services does not constitute TI's approval, warranty or endorsement thereof.

B010208

The platform bar, OMAP and SmartReflex are trademarks of Texas Instruments. All other trademarks are the property of their respective owners.